

# San Bernardino County Non-Motorized Transportation Plan March 2011 (Revised June 2018)



**cta**

San Bernardino County  
Transportation Authority

# Table of Contents

## ES Executive Summary

ES.1.0 Introduction .....	ES-1
ES.1.1 Overview of NMTP Development Process .....	ES-1
ES.1.2 NMTP Structure .....	ES-3
ES.2.0 Local Jurisdiction Plans.....	ES-4
ES2.1 Goals .....	ES-4
ES.2.2 Policies .....	ES-6
ES.3.0 Bicycle Planning .....	ES-6
ES.3.1 Types of Riders.....	ES-6
ES.3.2 Existing Bicycle Network .....	ES-7
ES.3.3 Future Bicycle Network .....	ES-7
ES.3.4 Recommendation for the Regional Bikeway System .....	ES-8
ES.4.0 Pedestrian Planning.....	ES-9
ES.5.0 Overview of Local Jurisdiction Plans.....	ES-9
ES.6.0 Design Guidelines.....	ES-10
ES.7.0 Implementation .....	ES-10
ES.7.1 Implementation Priorities.....	ES-10
ES.7.2 Coordination of Responsibilities for Project Delivery .....	ES-11
ES.7.3 Funding Opportunities.....	ES-12

## 1.0 Introduction

1.1 Purpose and Need for the Non-Motorized Transportation Plan.....	1-1
1.2 The San Bernardino Count Setting .....	1-2
1.3 Overview of the NMTP Development Process .....	1-6
1.4 Relationship to Other Planning Efforts .....	1-7
1.5 Structure of the NMTP .....	1-10

## 2.0 System Overview and Policies

2.1 Study Area Characteristics .....	2-1
--------------------------------------	-----



2.2 Goals.....	2-4
2.3 Policies.....	2-4
3.0 Bicycle Planning	
3.1 Classes of Bikeways.....	3-1
3.2 Types of Bicycle Riders .....	3-2
3.3 Estimates of Commuter Bicycle Trips .....	3-3
3.4 Existing Bicycle Network.....	3-5
3.5 Future Bicycle Network.....	3-6
3.6 Recommendations for the Regional Bikeway System.....	3-7
4.0 Pedestrian Planning	
4.1 Issues in Pedestrian Access and Mobility .....	4-1
4.2 Regional Pedestrian Facility Programs .....	4-3
5.0 Local Jurisdiction Plans	
5.1 Overview .....	5-1
5.2 Local Jurisdiction Plans .....	5-2
6.0 Design Guidelines	
6.1 Definitions.....	6-1
6.2 Bicycle Design Recommendations.....	6-2
6.3 Emerging Innovations .....	6-17
6.4 Bicycle Parking and Facilities .....	6-21
6.5 Pedestrian Design Recommendations.....	6-26
6.6 Bicycle Facility Maintenance.....	6-28
6.7 Security .....	6-28
6.8 Liability .....	6-28
7.0 Plan Implementation	
7.1 Implementation Priorities .....	7-1
7.2 Coordination of Responsibilities for Project Delivery.....	7-2

7.3 Funding Opportunities .....	7-3
Appendix A – update to the General Plan Guidelines – Complete Streets and the Circulation Element .....	A-1
Appendix B – Deputy Directive – Complete Streets – Integrating the Transportation System .....	B-1

# Executive Summary

---

## ES.1.0 Introduction

A safe, interconnected cycling and walking system can be a major asset to both individual communities and to an urban area, particularly one as well suited to these activities as San Bernardino County. The climate and topography are highly conducive for these and other outdoor pursuits. Both natural and man-made corridors provide ideal opportunities for development of a comprehensive system of cycling facilities, pathways, and trails. Even though San Bernardino County is known for its recreational opportunities, such a system is not well developed in many areas of the County.

However, progress is being made. In 2001, the combined total of centerline miles of bicycle infrastructure for all jurisdictions was 53 miles. As of 2011, the combined total of centerline miles of bicycle infrastructure for all jurisdictions is 468 miles. This represents an eight-fold growth in the County's bicycle infrastructure.

The challenge ahead involves developing a cohesive, integrated plan and identifying sources of funds to implement that plan. This is the goal of the San Bernardino County Non-Motorized Transportation Plan (NMTP). The NMTP of 2001 and the 2006 update have taken us part way there. This 2011 Plan hopes to take the development of such systems to another level. It identifies a comprehensive network, with a focus on the bicycle system. It is also a response, in part, to the initiatives to reduce vehicle travel and greenhouse gas emissions embedded in California Senate Bill 375 (SB 375). The Plan satisfies the State of California requirements of a Bicycle Transportation Plan (BTP) for purposes of Caltrans Bicycle Transportation Account (BTA) funding.

Implementation of the Plan will be a win-win on multiple fronts, and a strong partnership among local governments, transportation agencies, and the citizens of San Bernardino County can make it happen. The 2011 San Bernardino County NMTP will serve as a vehicle for communicating the non-motorized vision for the County, which is represented by the collective visions of each jurisdiction. Although the jurisdictions will be responsible for implementation of the Plan, it is important to have a Plan that cuts across subareas and jurisdictions so that coordination can occur on a physical facility level as well as in scheduling and funding.

## ES.1.1 Overview of NMTP Development Process

The development of the 2011 NMTP was a collaborative effort between SANBAG and local jurisdictions in San Bernardino County, with policy oversight by the SANBAG Board of Directors. The existing 2006 update of the NMTP and the associated local jurisdiction plans provided the starting point, but the 2011 Plan represents a wholesale upgrade of the entire document, focusing principally on the bicycle system, but on the walking environment as well.

SANBAG staff conducted an initial inventory of all existing Class I, II and III bicycle facilities in the County and rode most of the facilities personally. This was supplemented by local jurisdiction inventory data. Existing facilities were then mapped, and proposed facilities from the



prior plan were superimposed. This served as the starting point for network development, representing an interactive process between SANBAG and local jurisdiction staff.

Basic criteria were applied to gauge the need and feasibility for additional bicycle facilities, including:

- Connections to major destination points and trip generators
- Connectivity within and across jurisdictional boundaries
- Potential for usage of exclusive rights-of-way (i.e. for Class I facilities)
- Physical characteristics of roadways and suitability for accommodation of bicycle facilities (i.e. for Class II and III facilities)
- Closing gaps between existing facilities
- Constructability and cost issues

Accident data were tabulated from the Statewide Integrated Traffic Records System (SWITRS), both by jurisdiction and for the County as a whole. A comprehensive countywide map of existing and proposed facilities was then prepared, and a draft subarea map was prepared for each jurisdiction. Each map was accompanied by tables of existing and proposed facilities, and a narrative was prepared describing both existing conditions and the bikeway plan for each. Construction costs were estimated for each improvement type and segment based on current unit cost factors (in 2010 dollars). The relevant sections were provided to each jurisdiction for review.

Typically two to three review cycles were undertaken before the city-level maps, tables, and text were finalized. These represented the “core” of the bicycle portion of the plan and were incorporated into Chapter 4. The Transportation Technical Advisory Committee (TTAC) served as a focal point for discussion of technical issues related to the NMTP. Periodic reviews of NMTP status were provided to the TTAC beginning in 2009.

The body of the report was completed and provided for local jurisdiction review in mid-February 2011. The report was reviewed by the TTAC and by individual jurisdictions, and comments were reflected in the text, as appropriate.

The SANBAG Plans and Programs Committee served as the committee with policy oversight throughout the process. The committee approved the proposed NMTP policies in October 2009 and received reports on the Plan in February and March, 2011. Following approval of the NMTP by the Committee on March 16 (action yet to come), the SANBAG Board approved the Plan on April 6 (action yet to come). Individual jurisdictions were responsible for approval of the Plan with their own city councils and the Board of Supervisors.

Public involvement opportunities have been available through the open meetings of the Plans and Programs Committee. Agendas have been posted and are available to all through the SANBAG website. However, direct outreach to the public and advocacy groups was limited during the course of the development of this Plan, due to the compressed timeline in which the Plan had to be prepared once the dates were set by the State for local jurisdiction applications for Bicycle Transportation Account funds. Nevertheless, one of the implementation actions listed in Chapter 7 is to take this significantly upgraded NMTP to both bicycle and pedestrian advocates and the general public. Comments and suggestions from these groups will be incorporated into the Plan, with another update of the NMTP anticipated by the end of 2012.

## ES.1.2 NMTP Structure

The Non-motorized Transportation Plan is organized into the following chapters:

### Executive Summary

1. Introduction
2. Regional System Overview and Goals, Objectives, and Policies
3. Bicycle Planning
4. Pedestrian Planning
5. Local Jurisdiction Bicycle Plans
6. Design Guidelines
7. Plan Implementation

Chapter 5 is the key chapter showing the NMTP for bikeways at the jurisdiction level. It includes an inventory of existing and proposed facilities, mileage statistics, accident data, and a narrative that ties each plan together. SANBAG acknowledges several Non-Motorized Transportation Plans prepared for other California jurisdictions from which information, graphics, and examples were drawn for inclusion in the San Bernardino County NMTP, specifically, bicycle plans for Stanislaus County, San Francisco Bay Area, and City of Portland. Additional information was extracted from the *Caltrans Design Manual, Chapter 1000 – Bikeway Planning and Design*, American Association of State Highway and Transportation Officials (AASHTO) *Guidelines for the Development of Bicycle Facilities*, and the Federal Highway Administration's *Manual on Uniform Traffic Control Devices (MUTCD)*.

## ES.2.0 Local Jurisdiction Plans

For purposes of the Non-Motorized Transportation Plan, the study uses the following study areas:

- East Valley
- West Valley
- Victor Valley
- Mountains
- Barstow Area
- Morongo Basin
- Needles Area

The subareas are generally consistent with the San Bernardino County Measure I subareas, with the exception of the San Bernardino Valley. The Valley Measure I Subarea was further disaggregated into the East Valley and West Valley to provide additional granularity when mapping the NMTP facilities. Each of these subareas has unique aspects and demographics relevant to establishing an effective NMTP. Chapter 2 further identifies and comments on the unique geographic and demographic elements for each subarea.

## **ES.2.1 Goals**

The infrastructure improvements and programs recommended in San Bernardino County for the NMTP will be shaped by the Plan's goals and policies. Goals provide the context for the specific policies discussed in the NMTP. The goals provide the long-term vision and serve as the foundation of the Plan. Goals are broad statements of purpose, while policies identify specific initiatives and provide implementation direction on elements of the Plan.

The following represent the goals of the NMTP:

1. Increased bicycle and pedestrian access - Expand bicycle and pedestrian facilities and access within and between neighborhoods, to employment centers, shopping areas, schools, and recreational sites.
2. Increased travel by cycling and walking - Make the bicycle and walking an integral part of daily life in San Bernardino County, particularly (for bicycle) for trips of less than five miles, by implementing and maintaining a bikeway network, providing end-of-trip facilities, improving bicycle/transit integration, encouraging bicycle use, and making bicycling safer and more convenient.
3. Routine accommodation in transportation and land use planning - Routinely consider bicyclists and pedestrians in the planning and design of land development, roadway, transit, and other transportation facilities, as appropriate to the context of each facility and its surroundings.
4. Improved bicycle and pedestrian safety - Encourage local and statewide policies and practices that improve bicycle and pedestrian safety.

## **ES.2.2 Policies**

A set of policy recommendations was approved the SANBAG Plans and Programs Committee in October 2009 and reconfirmed in February 2011. The policies are as follows:

1. Local jurisdictions are the agencies responsible for the identification of non-motorized transportation projects within their jurisdiction for inclusion into the Plan. SANBAG shall only serve in an advisory capacity with respect to the identification of projects on the regional network. SANBAG shall provide advice on the inclusion of projects that may serve to better establish connectivity between jurisdictions, intermodal facilities and regional activity centers. However, local jurisdictions have sole authority over all projects included in the Plan
2. Local jurisdictions are also responsible for implementation of the projects included in the NMTP. SANBAG may provide advisory support to jurisdictions in the project development process on request. Should SANBAG be requested to provide assistance delivering a project in the Plan, such instances should be limited to development of regional non-motorized transportation facilities that provide connectivity to more than one jurisdiction or complete gaps within the regional non-motorized transportation network or serve to provide better access to transit facilities.



3. SANBAG shall, when feasible, support local education and safety efforts currently being implemented through local law enforcement, highway patrol, Caltrans and schools to better educate children and adults on the safe use of bicycles and to promote the non-motorized transportation system.
4. SANBAG shall prepare and update the comprehensive map identifying the County's non-motorized transportation system using its in-house GIS capabilities. Maintenance of the maps is also an important element of SANBAG's proposed 511 Traveler Information System.
5. SANBAG shall work with its member agencies to develop a regional way-finding system to assist travelers to identify the non-motorized transportation system. Any such system developed shall be developed in collaboration with local jurisdictions, will afford an opportunity for member agency customization, and promote connectivity to transit facilities, park and ride lots, and other regional activity centers.
6. SANBAG shall work with and encourage member agencies to incorporate non-motorized transportation facilities into general and specific plans as well as provide assistance in identifying design standards that provide for pedestrian- and bicycle-friendly access to transit facilities.
7. SANBAG shall use the NMTP as one component of the overall strategy to reduce greenhouse gas emissions pursuant to SB 375.
8. SANBAG shall work with and encourage transit operators to provide end-of-trip pedestrian and bicycle-serving facilities, such as bike lockers, racks, and capacity on transit vehicles to carry bicycles and better facilitate the integration and use of non-motorized transportation within the regional transportation system.
9. SANBAG shall use this plan as the basis to allocate state, federal, and local funds for delivery of non-motorized transportation improvements. Fund types may include, but are not limited to, federal Transportation Enhancement (TE), Congestion Mitigation and Air Quality (CMAQ), state Bicycle Transportation Account (BTA), and Transportation Development Act (TDA) Article 3 funds.
10. SANBAG shall work with member agencies to coordinate delivery of the NMTP and projects contained in the Nexus Study.
11. SANBAG shall work with member agencies to identify state/federal bicycle and pedestrian infrastructure or planning grant opportunities. When funding opportunities arise, SANBAG shall work to support local jurisdiction grant applications or collaborate with local jurisdictions to directly submit grant applications for projects in the Plan.
12. SANBAG and member agencies shall conduct regular bicycle and pedestrian counts to monitor the effects of implementation of the NMTP. SANBAG shall work to identify funding for the monitoring of Class I, separated shared-use facilities, so that no financial impact is borne by the local jurisdictions for collection of count information. Counts conducted on Class II and Class III, on-street bicycle facilities, shall correspond with counting for intersections that are both on the non-motorized network and require CMP Monitoring as outlined in the Congestion Management Program. When counts for non-

CMP intersections are desired, SANBAG shall be responsible for identifying funding for such counts.

These policies constitute a modest expansion of SANBAG's role in implementing the NMTP. Most of the policy recommendations are incorporated into SANBAG's current activities, although they may not be explicitly stated. All of the proposed policies are consistent with the agency's role as a County Transportation Commission and a Council of Governments. Moreover, SANBAG programs significant state, federal and local funding sources to implement the components of the NMTP, and needs to play an active role in providing for regional non-motorized transportation from that perspective as well.

### **ES.3.0 Bicycle Planning**

Chapter 3 provides an overview of bicycle planning as it relates to the San Bernardino County Non-Motorized Transportation Plan. The chapter begins by outlining the classes of bicycle facilities. For the purposes of the NMTP, there are three classes of bicycle facilities and are as follows:

- Class I (Share Use or Bike Path): A bikeway physically separated from any street or highway. Shared Use Paths may also be used by pedestrians, skaters, wheelchair users, joggers, and other non-motorized users.
- Class II (Bike Lane): A portion of roadway that has been designated by striping, signaling, and pavement markings for the preferential or exclusive use of bicyclists.
- Class III (Bike Route): A generic term for any road, street, path, or way that in some manner is specifically designated for bicycle travel regardless of whether such facilities are designated for the exclusive use of bicycles, or are to be shared with other transportation modes.
- Class IV (Separated Bikeway): A bikeway for the exclusive use of bicycles and includes a required separation between the bikeway and the through vehicular traffic. The separation may include, but is not limited to, grade separation, flexible posts, inflexible posts, inflexible barriers, or on-street parking.

#### **ES.3.1 Types of Riders**

Despite the advances various cities have made in facilitating bicycling, many individuals still have concerns about the safety of bicycle transportation. Other bikeway plans have used a typology to categorize riders based on their approach to bicycling. A more thorough description of the four classes of bike riders identified by Alta Planning in collaboration with the City of Portland include:

- Strong and Fearless
- Enthused and Confident
- Interested but Concerned
- Not Interested

Of course there are limitations to any model that categorizes individuals; however, there is still some utility to considering these four generalizations, namely that it forces SANBAG to better think about who the plan is intended to serve. A major premise of this plan is that the residents

who are described as ‘interested but concerned’ will not be attracted to bicycle for transportation by the provision of more bike lanes, but may be more willing to ride if a network of low-stress bikeways is provided.

## **ES.3.2 Existing Bicycle Network**

### **ES.3.2.1 Overview**

San Bernardino County has some excellent non-motorized facilities already in place for both recreation and commuting. The following describes these assets in detail and their relationship to the NMTP.

The growth of the non-motorized system has been substantial during the past decade. In 2001, the combined total of centerline miles of bicycle infrastructure for all jurisdictions was 53 miles. As of 2011, the combined total of centerline miles of bicycle infrastructure for all jurisdictions is 468 miles. This represents an increase of 415 centerline miles and a 780% growth in the County’s bicycle infrastructure.

Subarea maps of existing and proposed bicycle facilities are provided in Figures ES.1 through ES.7. The full set of maps may be referenced at the end of the Executive Summary. Additional information and tabular summaries of existing and proposed route mileage are provided for each individual jurisdiction in Chapter 5.

### **ES.3.2.2 Existing Regional Non-Motorized Assets**

San Bernardino County has some excellent non-motorized facilities already in place for both recreation and commuting. Chapter 3 more thoroughly describes the assets, but the NMTP recognizes the following as assets within the context of the Plan.

- Pacific Electric Trail
- Santa Ana River Trail
- Flood Control Channels
- Power Line Corridors
- Cajon Pass Connector – Route 66 Heritage Trail
- Orange Blossom Trail

## **ES.3.3 Future Bicycle Network**

In addition to the above-mentioned existing regional assets that span across cities, many jurisdictions have developed their own Class I, Class II, and/or Class III bikeways. Collectively, these represent the bikeways portion of the NMTP. Figures ES.1 through ES.7 showcase these future facilities at the subarea level. Table ES.1 summarizes the total centerline mileage of existing and planned bicycle network by class. These mileage totals represent a summation of those in the individual jurisdiction plans. Because some of the planned facilities represent



conversions from one class to another, the total existing plus planned is a slight over-counting of the actual mileage expected when the plan is complete.

**Table ES.1. Summary of Existing and Planned Bicycle Network Centerline Mileage**

(Note: Total existing plus planned represents a slight over-representation of the future network totals – see text.)

	Class I	Class II	Class III	Total
Existing	78.1	270.1	116.3	464.5
Planned	277.9	756.6	247.6	1282.1
Total	356.0	1026.7	363.9	1746.6

The local jurisdiction plans in Chapter 5 are drawn from the subarea maps and provide a more detailed discussion on specific bikeway facilities, end-of-trip facilities, and project priorities, where appropriate. Chapter 6 addresses design considerations when implementing bicycle facilities. Chapter 7 presents an overall implementation strategy and priorities.

### ES.3.4 Recommendations for the Regional Bikeway System

Specific project lists, recommendations, and priorities are contained in the individual jurisdiction bicycle plans in Chapter 5. This section provides recommendations that are regional in nature, with emphasis on the physical infrastructure in San Bernardino County. Chapter 7 presents an implementation strategy that takes these a step further, and provides regional priorities.

1. Deliver the Class I, II and III identified in the subarea maps referenced in Chapter 3. Although the Class I facilities can be considered a backbone bicycle system, there is much more to the network than just Class I facilities. Other types of facilities can also be delivered more quickly and less expensively, improving regional connectivity.
2. Develop better bicycle connectivity between cities and subareas of the County by coordinating the location and staging of network improvements. This must include improved collaboration with Caltrans, given the number of State highways connecting the subareas. Connectivity on Class II and Class III bicycle facilities can be increased by prioritizing the “low-hanging fruit” – parts of the regional system that are low-cost, close gaps in the system, and provide connections to key destinations.
3. Develop a better “sense of a system” through improved signage, markings, and way-finding for both cyclists and pedestrians.
4. Develop an improved inventory of end-of-trip facilities, particularly at transit stations, schools, other public buildings, and major employment centers.
5. Proactively coordinate integration of cycling and walking accommodations with the State’s Complete Streets requirements, once guidelines are finalized by the State.
6. Proactively coordinate integration of cycling and walking access accommodations to and from transit stations.
7. Continue safety education and promotion of cycling through schools, newsletters, and public websites.

## **ES.4.0 Pedestrian Planning**

It is often perceived that pedestrian transportation is essentially a local concern, given the length of most pedestrian trips and the manner in which these trips are usually contained within a given area, whether that area is a schoolyard, a shopping center, a college campus or a downtown business district. At the same time, federal legislation and funding programs remind us that regional, state and federal levels of government all have a stake in designing the multi-modal transportation system to serve the needs of all travelers. It is often said that pedestrian planning is a part of “alternative transportation planning,” yet there is no more basic mode of transportation than getting around on foot. Indeed, no trip involving a car, bus, train, airplane or other mode can even begin without a pedestrian journey taking place. Regional transportation facilities such as airports and transit stations must be designed around the needs of the pedestrian if they are to fulfill their mission.

For purposes of this plan, the following activities are considered regional priorities for pedestrian planning and project development:

1. Improving pedestrian access to transit;
2. Removing existing barriers to pedestrian travel;
3. Development of regional trails and pathways which provide improved pedestrian access to destinations;
4. Improvement of the pedestrian environment on major regional arterials and at regional activity centers.

Chapter 4 describes potential elements of a regionally based pedestrian transportation effort. The core focus of pedestrian planning, as it relate to this plan, include the following:

- Improving transit access
- Preventing and eliminating barriers to pedestrian travel
- Developing regional trails and pathways
- Better providing for pedestrian travel on major regional arterials and at activity centers

## **ES.5.0 Overview of Local Jurisdiction Plans**

Chapter 5 represents the heart of the Non-Motorized Plan for bicycle facilities. The chapter contains individualized plans for each of the 25 jurisdictions in San Bernardino County, with emphasis on the bicycle system. The plans all contain the same structure, including the following elements:

- The population of the jurisdiction
- An overview of the jurisdiction, including uniquely tailored commentary about its geography or historical elements.
- A summary of the jurisdiction’s existing and proposed land use.
- A map of the jurisdiction’s General Plan land use coverage, including information on schools, parks, residential, commercial and industrial land uses.

- A map of the jurisdiction’s existing and proposed bicycle facility networks.
- A textual description of the existing non-motorized condition.
- A textual description of the jurisdiction’s past investment in non-motorized infrastructure
- A textual description of the jurisdiction’s non-motorized priorities, if any.
- Tables that document existing, future and priority bicycle facility projects with class, mileage, and estimated costs.
- A summary table of multi-modal connections.
- Documentation of municipal code pertaining to the provision of non-motorized serving infrastructure, if available.
- A summary of non-motorized serving infrastructure, including bike racks, bike lockers and shower facilities where identified.
- A table with collision information and an analysis as to how the number of collisions relates to the state average.
- Information on jurisdiction safety and education programs related to non-motorized transportation.

## **ES.6.0 Design Guidelines**

Chapter 6 provides details on the recommended design and operating standards for the San Bernardino County Bikeway System.

The Caltrans Design Manual, Chapter 1000 – Bikeway Planning and Design establishes the standards for bicycle facility design within the state of California. These standards are, for the most part, consistent with the American Association of State Highway and Transportation Officials (AASHTO) Guidelines for the Development of Bicycle Facilities. The Caltrans standards provide the primary basis for the design recommendations that follow.

## **ES.7.0 Implementation**

Chapter 7 provides an implementation strategy for the NMTP and a description of funding opportunities for the proposed bicycle and pedestrian improvements. The implementation strategy consists of the following elements:

- Identification of implementation priorities (both infrastructure and institutional)
- Coordination of responsibilities for project delivery
- Identification and pursuit of funding opportunities

Each of these elements is described below.

### **ES.7.1 Implementation Priorities**

The setting of priorities for the NMTP involves more than just the identification of priority projects, although it does include that. Priorities must also consider institutional initiatives that pave the way for the delivery of priority projects. Thus, the priorities for the NMTP include a



restatement of some of the recommendations for system improvement identified in Chapter 3, plus several institutional initiatives to foster program and project delivery. The following represent NMTP priorities (not in order of importance):

1. Deliver the Class I backbone bicycle system. Although the Class I facilities can be considered a backbone bicycle system, there is much more to the network than just Class I facilities. Other types of facilities can also be delivered more quickly and less expensively, improving regional connectivity.
2. Develop better bicycle connectivity between cities and subareas of the County. This must include improved collaboration with Caltrans, given the number of State highways connecting the subareas.
3. Increase connectivity on Class II and Class III bicycle facilities by prioritizing the “low-hanging fruit” – parts of the regional system that are low-cost, close gaps in the system, and provide connections to key destinations.
4. Develop a better “sense of a system” through improved signage, markings, and way-finding for both cyclists and pedestrians
5. Proactively coordinate integration of cycling and walking accommodations with the State’s Complete Streets requirements
6. Proactively coordinate integration of cycling and walking access accommodations to and from transit stations
7. Aggressively pursue grant funding and devote additional programmatic funding to non-motorized facilities
8. Identify individuals within SANBAG, local jurisdictions, Caltrans, and transit agencies to be points of contact on non-motorized facility implementation and ensure communication on non-motorized topics among the agencies.

The full identification of Class I bicycle facilities is contained in the subarea maps in Chapter 3 and in the individual jurisdiction plans in Chapter 5. Several key Class I projects listed in the 2001 NMTP and the 2006 update that would be considered as part of the Class I backbone system include:

- Santa Ana River Trail
- Pacific Electric Trail
- Orange Blossom Trail
- San Timoteo Canyon Trail
- Riverwalk Trail
- Cajon Pass Connector – Route 66 Heritage Trail

## **ES.7.2      Coordination of Responsibilities for Project Delivery**

The policies listed in Chapter 2 provide guidance as to how implementation is to occur. Local jurisdictions are responsible for the identification, prioritization, and implementation of non-motorized transportation projects within their jurisdiction, with SANBAG serving in an advisory capacity and coordinating activity where necessary. SANBAG is also to work with local jurisdictions to develop a regional way-finding system.

The policies also identify a role for SANBAG to pursue grant opportunities for State/federal bicycle and pedestrian infrastructure or planning. SANBAG will support local jurisdiction grant applications or collaborate with local jurisdictions to directly submit grant applications for

projects in the Plan. The pursuit of grant application opportunities is one of the areas identified in the Plan where substantial improvement is possible, as San Bernardino County has been under-represented in the share of non-motorized grant funds that have been awarded in the past.

This Plan recognizes that regional cooperation among local agencies is critical in the selection and promotion of priority projects and the allocation of local funding to ensure an orderly implementation of an effective bicycle system.

The schedule for implementation on a year-to-year basis can be better coordinated and should be determined by:

- Relationship to the regional system
- Readiness of each project in terms of local support;
- CEQA approvals;
- Right-of-way requirements;
- Timing with other related improvements; and/or
- Success in obtaining competitive funding.

SANBAG staff should monitor the short- and mid-term projects identified in this Plan and subsequent updates, and maintain a comprehensive list of projects and funding allocations. A rolling five-year schedule of short-term projects should be identified so that resources can be focused and coordinated to ensure attention to priority projects over time. This is not to the exclusion of other local projects, but regional connectivity to support commuting and other longer-distance trips is an emphasis of this Plan. Each year the TTAC and SANBAG staff will review the list of projects slated for priority that year, review the readiness of each project to be proposed for funding, and consider the sequencing of the projects. This process does not preclude cities and local agencies from continuing to submit other local projects for funding consideration.

### **ES.7.3 Funding Opportunities**

There are a variety of potential funding sources - including local, state, regional, and federal programs - that can be used to construct the proposed bicycle and pedestrian improvements. Most of the federal, state, and regional programs are competitive, and involve the completion of extensive applications with clear documentation of the project need, costs, and benefits. In addition, the majority of the programs require a local match, usually 10-15% of the total project cost.

The recipients of grant funds for many of these programs are then required to monitor the projects for compliance with the program guidelines. Although the pursuit and administration of grant moneys can require a significant amount of staff time, grant funding allows for the construction of more miles of facilities.

The key to receiving funds will be to tailor grant requests to meet specific requirements and criteria, leverage grants with matching funds, and demonstrate a commitment by the jurisdiction to implement and maintain the system. Serious intent would include adoption of the NMTP, development of an additional local plan, inclusion of bikeway improvements into the Capital

Improvements Plan, adoption of recognized design and operating standards, and public/political support.

A detailed breakdown of available funding programs is provided in Chapter 7. Tracking program specifics can be difficult as program guidelines are modified regularly. Thus it is important to verify program dates and deadlines with the program administrator since specific amounts and deadlines can change from year to year. In general, however, the known broad groups of funding sources are broken into three broad categories—federal, state and local—with further documentation of the known fund sources pertinent to each of the broad groups called out as bullet points. For more detailed information on any of the funding sources, see the more detailed discussion in Chapter 7.

# 1.0 Introduction

---

## 1.1 Purpose and Need for the Non-Motorized Transportation Plan

A safe, interconnected cycling and walking system can be a major asset to both individual communities and to an urban area, particularly one as well suited to these activities as San Bernardino County. The climate and topography are highly conducive for these and other outdoor pursuits. Both natural and man-made corridors provide ideal opportunities for development of a comprehensive system of cycling facilities, pathways, and trails. Even though San Bernardino County is known for its recreational opportunities, such a system is not well developed in many areas of the County.

However, progress is being made. In 2001, the combined total of centerline miles of bicycle infrastructure for all jurisdictions was 53 miles. As of 2011, the combined total of centerline miles of bicycle infrastructure for all jurisdictions is 468 miles. This represents an eight-fold growth in the County's bicycle infrastructure.

It is not difficult to convince the public that the provision of bicycle and walking facilities makes sense as a community investment. One of the themes emerging from the public meetings to develop a County vision is that residents place high value on cycling and walking features within their communities. Cycling and walking trails have been listed in the County's "Countywide Vision Project" meetings as a part of our infrastructure needing improvement and are also commonly highlighted as a selling point in advertising for new communities.

These facilities, and the activities enabled by them, are good for our health, good for our economy, good for our environment, and good for our quality of life. The facilities can also be implemented without great expense. There is every reason to believe that San Bernardino County can and should be one of the centers of cycling and pedestrian activity in Southern California.

The challenge ahead involves developing a cohesive, integrated plan and identifying sources of funds to implement that plan. This is the goal of the San Bernardino County Non-Motorized Transportation Plan (NMTP). The NMTP of 2001 and the 2006 update have taken us part way there. This 2011 Plan hopes to take the development of such systems to another level. It identifies a comprehensive network, with a focus on the bicycle system. It is also a response, in part, to the initiatives to reduce vehicle travel and greenhouse gas emissions embedded in California Senate Bill 375 (SB 375).

Implementation of the Plan will be a win-win on multiple fronts, and a strong partnership among local governments, transportation agencies, and the citizens of San Bernardino County can make it happen. The 2011 San Bernardino County NMTP will serve as a vehicle for communicating the non-motorized vision for the County, which is represented by the collective visions of each jurisdiction. Although the jurisdictions will be responsible for implementation of the Plan, it is important to have a Plan that cuts across subareas and jurisdictions so that coordination can occur on a physical facility level as well as in scheduling and funding.

The remainder of Chapter 1 describes the context of San Bernardino County, the process of NMTP development, and the relationship to other plans.

## **1.2 The San Bernardino County Setting**

San Bernardino County, located in the northeastern portion of Southern California, boasts a wide variety of urban and rural settings. Framed by Los Angeles County on the west, Riverside County to the south, and extending to Nevada and Arizona to the east, the County serves as a major gateway into and out of the Southland. Interstate 10, State Route 60, and State Route 210 provide substantial east-west mobility in the Valley Region. Interstates 15 and 215 and SR-71 provide north-south freeway connectivity. I-15 connects Riverside and San Diego Counties to the south, and continues over the Cajon pass to the cities of the high desert and northward to Las Vegas. See map of the County and its subareas in Figure 1-1.

State Routes 18 and 330 and Scenic State Highway 38 provide connections to the mountains surrounding the Valley, providing linkages for tourists and residents from the Valley to Lake Arrowhead, Big Bear Lake and other mountain communities. State Routes 18, 62, 138, and 247 provide additional connectivity in the Victor Valley, Morongo Basin and surrounding communities.

The County is connected to other regional centers by scheduled transit and commuter rail service provided by Metrolink. The San Bernardino Metrolink line is the most heavily traveled commuter rail line in Southern California, providing 36 trains per day to and from San Bernardino, Los Angeles and intervening cities. Metrolink service also is provided from San Bernardino to Riverside and Orange Counties, with 8 trains per day. Omnitrans provides local and express bus service within the County and into adjacent communities. Five other transit operators provide transportation for work and non-work trips. The SANBAG Long Range Transit Plan provides a vision for rail and transit service in the Valley Region of San Bernardino County and is a framework around which some of the bicycle and pedestrian facilities can be planned.

LA/Ontario International Airport (ONT) is located in the west valley and is the third busiest passenger airport in Southern California after Los Angeles International Airport (LAX) and John Wayne Airport in Orange County. It is also the second busiest hub for freight movement and is adjacent to one of the principal focal points of logistics and distribution in California.

San Bernardino County is known for its world-class transportation and distribution centers, owing much to its historic role as a crossroads of rail transportation and now also serving the same function for truck transportation. The area is also known for its historic agricultural heritage in citrus and vineyard operations, although today, the residential and commercial growth has severely curtailed agriculture in the Valley.

The environment for cycling and walking in San Bernardino County is ideal. The climate is temperate, with a range in average high temperatures for the Valley of 67 to 96 degrees, in the Victor Valley from 60 to 98 degrees, and in the Morongo Basin from 64 to 108 degrees. The average high temperatures in Big Bear Lake range from 47 to 81 degrees. Rainfall is moderate and concentrated in the November through March timeframe, while humidity is generally low. The topography outside of the mountain areas is typically flat to moderately sloping.





Despite the suitability of the climate and topography, relatively little commuter-related cycling occurs. Statistics from the American Community Survey (2006-2009) indicate the percentage of trips to work by bicycling and walking. The bike-to-work percentage varies by jurisdiction, but is only about 0.4% countywide. The walk-to-work percentage is higher, but still only about 1.5%, and this statistic was heavily influenced by very high walk-to-work percentages at the Twentynine Palms Marine Base.

Table 1.1 shows that the percent of trips to work by bicycle are low throughout Southern California, and presumably throughout the rest of the United States. The counties are not greatly different from one another in terms of the percentage of bike/walk trips to work.

**Table 1.1 Percent of Trips to Work by Bicycle and Walking for Southern California Counties**  
(Source: American Community Survey 2006-2009)

COUNTY	Total Trips to Work	No. of Bike Trips	No. of Walk Trips	% Bike Trips	% Walk Trips
Imperial	43,205	195	685	0.45%	1.59%
Los Angeles	3,858,750	20,975	54,630	0.54%	1.42%
Orange	1,313,985	9,500	13,220	0.72%	1.01%
Riverside	590,515	2,825	5,810	0.48%	0.98%
San Bernardino	658,710	2,475	10,070	0.38%	1.53%
Ventura	345,660	2,165	3,930	0.63%	1.14%
TOTAL	6,810,825	38,135	88,345	0.56%	1.30%

Streets and Highways Code Section 891.2 requires an estimate of the number of existing bicycle commuters in San Bernardino County and an estimate of the number of bicycle commuters that may be present upon implementation of the NMTP. Given that the number of workers in San Bernardino County is approximately 870,000, one can estimate that there are currently 3300 commuting cyclists daily in the County. A reasonable goal for increased bicycle mode share is to achieve the region-wide average (0.56%) over the life of the plan. This increased mode share taken together with an increase in workers would result in approximately 5500 commuting cyclists within the next 20 years.

Anecdotal evidence indicates that substantial recreational cycling occurs in San Bernardino County in areas where facilities are available. If San Bernardino County is generally representative of the nation, the following national statistics help to characterize the cycling and walking habits of the population (Source: National Survey of Bicyclist and Pedestrian Attitudes and Behavior, National Highway Traffic Safety Administration, August 2008.). The survey was of persons age 16 and older.

National Bicycling Statistics

- 27% of the population age 16 and older rode a bicycle at least once in the last 30 days; translated to San Bernardino County, this would mean approximately 300,000 persons 16 and older road their bike in the last month.
- 19% indicate that they ride at least once per week in the summer months; 57% indicate that they never ride a bike

- 29% of bicycle trips are for recreational purposes, 24% are for exercise/health, 14% are for personal errands, and only 5% are for commuting to work or school
- Access to bicycles - Slightly less than half (46%) of those 16 and older have regular access to a bicycle, with access increasing with increases in household income.
- About 43 percent ride a bicycle at least once in the summer months.
- Bicycling declines with age, with those under 20 most likely to bicycle and doing so more frequently, while the majority over 45 did not bicycle during the summer months.
- About half of all trips (48%) were made on paved roads. An additional 13 percent were on shoulders of paved roads, and 5 percent on bike lanes on roads. One in 7 was made on sidewalks (14%) and 13% were made on bike trails/paths.
- Half of bicyclists nationally say bike paths are available in the area they ride, while 32 percent say bike lanes are available.
- Over half of those who do not use available bicycle paths or lanes say they don't use them because they are not convenient, available, or go where they need to go.
- More than one in 10 bicyclists (13%) felt threatened for their personal safety on the most recent day they rode their bicycle, 88 percent of these feeling threatened by motorists.
- About 4 percent of bicyclists, or 2.04 million nationally, were injured while riding in the past two years. About 25% of these were hit by a motorist.
- Nearly half (48%) of those 16 and older are satisfied with how their local community is designed for making bicycle riding safer.
- Almost half (48%) of those 16 and older would like to see improvements to bicycle facilities, including more bike lanes (38%) and bike paths (30%).

#### National Walking Statistics

- About 86 percent of people 16 or older walked, jogged or ran outdoors for 5 minutes or more during the summer months, with 78 percent doing so within the past 30 days.
- Walking in the past 30 days decreases to 66 percent for those over 64.
- Personal errands (38%), exercise (28%) and recreation (21%) are the most common reasons for walking trips.
- Nearly half (45%) of the walking trips were mostly made on sidewalks, and 25 percent were mostly on paved roads. Just 6 percent were made mostly on bike or walk paths or trails.
- About 6 percent of pedestrians felt their personal safety threatened on their most recent trip, with 62 percent saying they felt threatened by motorists.

- Almost three-quarters of people 16 and older (73%) are satisfied with how their local community is designed for walking, though one-third would like to see changes including more sidewalks (42%) and more street lights (17%).

The physical infrastructure for cycling and walking varies widely from one city to another and within cities as well. Some of the newer communities such as Rancho Cucamonga have worked closely with developers to create walkable residential areas with an abundance of trails, bicycle facilities and other amenities. Some older communities such as Redlands have had the historical benefit of sidewalks, grid streets, and streets wide enough for bicycles and autos to co-exist. Each city or unincorporated area has its strengths and weaknesses with respect to the suitability of infrastructure for walking and cycling.

One of the purposes of the NMTP is to re-think the role of some of the streets in our communities – who uses them, how they function, and how they are designed. It is while the infrastructure of the new century is being designed and constructed that the needs of all transportation users must be taken into account. Quality is an easier goal to achieve when designed from the beginning – and prohibitively expensive to add after the fact. California’s “Complete Streets” legislation (AB 1358) pushes local governments to think multi-modally when constructing roadway infrastructure, and not consider autos and trucks exclusively.

### **1.3 Overview of the NMTP Development Process**

The development of the 2011 NMTP was a collaborative effort between SANBAG and local jurisdictions in San Bernardino County, with policy oversight by the SANBAG Board of Directors. The existing 2006 update of the NMTP and the associated local jurisdiction plans provided the starting point, but the 2011 Plan represents a wholesale upgrade of the entire document, focusing principally on the bicycle system, but on the walking environment as well.

SANBAG staff conducted an initial inventory of all existing Class I, II and III bicycle facilities in the County and rode most of the facilities personally. This was supplemented by local jurisdiction inventory data. Existing facilities were then mapped, and proposed facilities from the prior plan were superimposed. This served as the starting point for network development, representing an interactive process between SANBAG and local jurisdiction staff.

Basic criteria were applied to gauge the need and feasibility for additional bicycle facilities, including:

- Connections to major destination points and trip generators
- Connectivity within and across jurisdictional boundaries
- Potential for usage of exclusive rights-of-way (i.e. for Class I facilities)
- Physical characteristics of roadways and suitability for accommodation of bicycle facilities (i.e. for Class II and III facilities)
- Closing gaps between existing facilities
- Constructability and cost issues

Accident data were tabulated from the Statewide Integrated Traffic Records System (SWITRS), both by jurisdiction and for the County as a whole. A comprehensive countywide map of existing and proposed facilities was then prepared, and a draft subarea map was prepared for each jurisdiction. Each map was accompanied by tables of existing and proposed facilities, and a narrative was prepared describing both existing conditions and the bikeway plan for each. Construction costs were

estimated for each improvement type and segment based on current unit cost factors (in 2010 dollars). The relevant sections were provided to each jurisdiction for review.

Typically two to three review cycles were undertaken before the city-level maps, tables, and text were finalized. These represented the “core” of the bicycle portion of the plan and were incorporated into Chapter 4. The Transportation Technical Advisory Committee (TTAC) served as a focal point for discussion of technical issues related to the NMTP. Periodic reviews of NMTP status were provided to the TTAC beginning in 2009.

The body of the report was completed and provided for local jurisdiction review in mid-February 2011. The report was reviewed by the TTAC and by individual jurisdictions, and comments were reflected in the text, as appropriate.

The SANBAG Plans and Programs Committee served as the committee with policy oversight throughout the process. The committee approved the proposed NMTP policies in October 2009 and received reports on the Plan in February and March, 2011. Following approval of the NMTP by the Committee on March 16 (action yet to come), the SANBAG Board approved the Plan on April 6 (action yet to come). Individual jurisdictions were responsible for approval of the Plan with their own city councils and the Board of Supervisors.

Public involvement opportunities have been available through the open meetings of the Plans and Programs Committee. Agendas have been posted and are available to all through the SANBAG website. However, direct outreach to the public and advocacy groups was limited during the course of the development of this Plan, due to the compressed timeline in which the Plan had to be prepared once the dates were set by the State for local jurisdiction applications for Bicycle Transportation Account funds. Nevertheless, one of the implementation actions listed in Chapter 7 is to take this significantly upgraded NMTP to both bicycle and pedestrian advocates and the general public. Comments and suggestions from these groups will be incorporated into the Plan, with another update of the NMTP anticipated by the end of 2012.

## **1.4 Relationship to Other Planning Efforts**

The San Bernardino County Non-Motorized Transportation Plan is intended to coordinate and guide the provision of all bicycle related plans, programs and projects within the County. As a countywide plan, it focuses on providing bikeway connections between the incorporated cities, adjacent counties and major regional destinations within the County. The Plan also identifies local jurisdiction priorities, where applicable, and serves as a guide regarding bikeway policies and design standards.

### **Southern California Association of Governments’ Regional Transportation Plan (RTP)**

The SCAG 2008 RTP contains a non-motorized section and is supported by a separate report for non-motorized transportation. The policies/desired outcomes expressed in this report include the following:

- Decrease bicyclist and pedestrian fatalities and injuries
- Increase accommodation and planning for bicyclists and pedestrians
- Increase bicycle and pedestrian use in the SCAG region as an alternative to vehicle trips
- Encourage development of local non-motorized plans
- Produce a comprehensive regional non-motorized plan

- Improve funding for non-motorized transportation

The San Bernardino County NMTP is consistent with these statements. In fact, the NMTP represents the implementation of several of these desired outcomes.

The RTP also contains mapping of non-motorized facilities that incorporates mapping prepared by subregions such as SANBAG. As such, the RTP is a coordinating document in particular for routes, pathways, and trails that cross county boundaries.

A major focus of the 2012 RTP is the development of a Sustainable Communities Strategy (SCS). This includes the focusing of land use activity within existing and future transit station areas and the planning for transportation strategies that enhance non-auto mobility, reduce energy consumption, and reduce greenhouse gases. Non-motorized transportation modes will play a prominent role in the SCS.

### **SANBAG Long Range Transit Plan (LRTP)**

The Long Range Transit Plan addresses the County's travel challenges and provides a system of transit facilities and services that can increase transit's role in the future. Given the large and diverse nature of the county, the plan is split geographically into three areas: San Bernardino Valley; Victor Valley; and rural areas. In the San Bernardino Valley, the LRTP includes major projects such the Redlands Rail system between San Bernardino and downtown Redlands, extension of the Gold Line to Montclair, with additional planning to LA/Ontario International Airport, and extensive Bus Rapid Transit network. The first segment of the BRT system between Cal State San Bernardino and Loma Linda is scheduled to be in operational service by 2015. There are many transit stations around which non-motorized facilities should be planned. Figure 1.2 shows the existing and future LRTP network in the Valley and approximate station locations around which land use and pedestrian/bicycle connectivity can be planned.

### **Improvement to Transit Access for Cyclists and Pedestrians**

SANBAG has received a grant from Caltrans under the Statewide or Urban Transit Planning Studies program for an effort entitled "Improvement to Transit Access for Cyclists and Pedestrians." The project seeks to identify a range of physical infrastructure improvements, such as more or better bicycle parking, better way-finding signage and better connections to nearby pedestrian paths, trails and bike lanes to encourage more people to walk or bike to Metrolink and planned E Street sbX stations. Such infrastructure improvements would provide Metrolink and sbX users with additional modal alternatives to and from the transit system, thereby decreasing automobile traffic within station catchment areas and reducing the need for automobile parking at station locations. Moreover, providing improved infrastructure within transit catchment areas will promote increased safety for pedestrians and cyclists. This planning effort should be completed near the end of Fiscal Year 2011-2012.





[00000000000&pnavid=null&recid=null&actid=null&groupid=null&ttype=main&pname=San Bernardino National Forest- Home.](#)

## Caltrans Bicycle Transportation Account

Although not a plan, the Bicycle Transportation Account (BTA) is an important program that annually provides State funds for city and county projects that improve safety and convenience for bicycle commuters. To be eligible for BTA funds, a city or county must prepare and adopt a Bicycle Transportation Plan (BTP) that complies with Streets and Highways Code Section 891.2. The BTP must be approved by the local agency's Regional Transportation Planning Agency.

Caltrans anticipates an appropriation of \$7.2 million annually for projects that improve safety and convenience for bicycle commuters. Streets and Highways Code (S&HC) Section 2106 stipulates the annual BTA funding level, subject to appropriation in the approved State budget. Per S&HC 891.4(b), funds are allocated to cities and counties on a matching basis that requires the applicant to furnish a minimum of 10 percent of the total project cost. No applicant shall receive more than 25 percent of the total amount transferred to the BTA in a single fiscal year. Additional information on funding sources for cycling and walking facilities is provided in Chapter 7.

## 1.5 Structure of the NMTP

The Non-motorized Transportation Plan is organized into the following chapters:

### Executive Summary

1. Introduction
2. Regional System Overview and Goals, Objectives, and Policies
3. Bicycle Planning
4. Pedestrian Planning
5. Local Jurisdiction Bicycle Plans
6. Design Guidelines
7. Plan Implementation

Chapter 5 is the key chapter showing the NMTP for bikeways at the jurisdiction level. It includes an inventory of existing and proposed facilities, mileage statistics, accident data, and a narrative that ties each plan together. SANBAG acknowledges several Non-Motorized Transportation Plans prepared for other California jurisdictions from which information, graphics, and examples were drawn for inclusion in the San Bernardino County NMTP, specifically, bicycle plans for Stanislaus County, San Francisco Bay Area, and City of Portland. Additional information was extracted from the *Caltrans Design Manual, Chapter 1000 – Bikeway Planning and Design*, American Association of State Highway and Transportation Officials (AASHTO) *Guidelines for the Development of Bicycle Facilities*, and the Federal Highway Administration's *Manual on Uniform Traffic Control Devices (MUTCD)*.

To be eligible for Bicycle Transportation Account (BTA) funds, a city or county must prepare and adopt a Bicycle Transportation Plan that addresses items a. - k. in Streets and Highways Code Section 891.2. Caltrans has prepared a checklist of requirements under this code section, and the NMTP references the pages of the Plan that address those requirements. These are listed in Table 1-2.

**Table 1.2. Requirements of Streets and Highways Code Section 891.2 and References to Pages in the Plan that Address these Requirements**

<b>Requirement</b>	<b>Pages</b>
a) The estimated number of existing bicycle commuters in the plan area and the estimated increase in the number of bicycle commuters resulting from implementation of the plan.	See pages 1-4, 3-3 and 3-4.
b) A map and description of existing and proposed land use and settlement patterns which shall include, but not be limited to, locations of residential neighborhoods, schools, shopping centers, public buildings, and major employment centers.	See Figures 2-1 through 2-7 in Chapter 2.
c) A map and description of existing and proposed bikeways.	See Figures 3-4 through 3-7 in Chapter 3.
d) A map and description of existing and proposed end-of-trip bicycle parking facilities. These shall include, but not be limited to, parking at schools, shopping centers, public buildings, and major employment centers.	See Figures 2-1 through 2-7 for locations of significant bicycle trip destinations. Most of these locations include bicycle racks. See Chapter 5 local plans for more specific info on end-of-trip facilities.
e) A map and description of existing and proposed bicycle transport and parking facilities for connections with and use of other transportation modes. These shall include, but not be limited to, parking facilities at transit stops, rail and transit terminals, ferry docks and landings, park and ride lots, and provisions for transporting bicyclists and bicycles on transit or rail vehicles or ferry vessels.	See page 3-6, map of transit system on page 1-8, and selected references in local plans in Chapter 5.
f) A map and description of existing and proposed facilities for changing and storing clothes	See page 3-6.
g) A description of bicycle safety and education programs conducted in the area included within the plan, efforts by the law enforcement agency having primary traffic law enforcement responsibility in the area to enforce provisions of the Vehicle Code pertaining to bicycle operation, and the resulting effect on accidents involving bicyclists.	Bicycle safety and education programs vary by jurisdiction. Please see local bicycle plans in Chapter 5.
h) A description of the extent of citizen and community involvement in development of the plan, including, but not limited to, letters of support.	See description of status of public involvement on page 1-7. Updates on NMTP progress have been provided at multiple meetings of the SANBAG Plans and Programs

Committee, open to the public.

- i) A description of how the bicycle transportation plan has been coordinated and is consistent with other local or regional transportation, air quality, or energy conservation plans, including, but not limited to, programs that provide incentives for bicycle commuting.

See description of plans with which the NMTP has been coordinated on pages 1-7 through 1-9.
- j) A description of the projects proposed in the plan and a listing of their priorities for implementation.

Projects and priorities are listed in individual local plans in Chapter 5. Implementation priorities are listed in Chapter 7.
- k) A description of past expenditures for bicycle facilities and future financial needs for projects that improve safety and convenience for bicycle commuters in the plan area.

Each local plan in Chapter 5 contains an estimate of prior expenditures and cost estimates for future facilities.

## 2.0 System Overview and Policies

---

This chapter provides an overview of the subareas within San Bernardino County as well as a set of overarching policies to guide the Plan and its implementation. The focus of the Plan is on a primary (rather than local) network of bikeway corridors for intercity and regional travel.

### 2.1 Study Area Characteristics

The study area of the Non-Motorized Transportation Plan includes the entire County and connections among communities. Because of its geographic size and diversity, San Bernardino County is divided into seven subareas for purposes of NMTP mapping:

- East Valley
- West Valley
- Victor Valley
- Mountains
- Barstow Area
- Morongo Basin
- Needles Area

Each of these subareas has unique aspects and demographics relevant to establishing an effective NMTP. Maps presented in this section show the road network, school locations, parks, park-and-ride lots, existing transit stations, and significant destinations (e.g. major shopping centers, airports, hospitals, etc.). Similar maps are provided in Chapter 3 with an overlay of existing and future bicycle facilities.

#### 2.1.1 San Bernardino Valley (East Valley and West Valley)

The San Bernardino Valley contains the most populous cities in the County and a rich selection of neighborhoods and destinations. Freeways and commuter rail connect it to other parts of Southern California and the adjacent counties of Los Angeles, Orange, and Riverside. There are 15 cities in the Valley: Chino, Chino Hills, Colton, Fontana, Grand Terrace, Highland, Loma Linda, Montclair, Ontario, Rancho Cucamonga, Redlands, Rialto, San Bernardino, Upland, and Yucaipa. Figures 2-1 and 2-2 provide separate maps showing the East Valley and West Valley. (Note: all maps are provided at the end of this chapter in the order referenced).

Numerous centers of shopping and retail attractions are scattered throughout this part of the County. Shopping malls such as Ontario Mills, Citrus Plaza, and Montclair Plaza serve as regional attractors, while the mixed-use Victoria Gardens embodies a new urbanist flavor in Rancho Cucamonga. Several other retail centers in almost every city provide big-box shopping convenience, and most cities have a small downtown area with a focus on local retail.

California State University San Bernardino and the University of Redlands, located close to the foothills, draw students from the state and beyond, while Chaffey College, San Bernardino Valley College, and Crafton Hills College, serve more local populations. In the western Valley, the cities of

Montclair and Upland border Los Angeles County and thus are close to University of La Verne and the Claremont Colleges.

Numerous institutions of healthcare are situated in the Valley, such as Loma Linda University Hospital, Arrowhead Regional Medical Center in Colton, Kaiser in Fontana and Ontario, Redlands Community Hospital, St. Bernadine's in San Bernardino, and San Antonio in Upland. These serve as major employment centers as well.

The Valley has an established transportation infrastructure that is complementary to the goals of the NMTP. For commuters, Metrolink provides regular train service to Downtown Los Angeles each weekday with some weekend service as well. The San Bernardino Line has stops in Montclair, Upland, Rancho Cucamonga, Fontana, Rialto, and San Bernardino. The Riverside Line primarily serves Riverside County, but also stops in Ontario. The Inland Empire-Orange County Line takes workers into Orange County via San Bernardino and cities in Riverside County. Most Metrolink stations serve as transit centers, providing benefits to commuters such as park-and-ride lots and transfers to local bus routes. The station at Montclair has ample parking and affords access to several Foothill Transit and OmniTrans bus lines. A planned transit center in Downtown San Bernardino will link the future Redlands light rail line with Metrolink and a new north-south bus rapid transit (BRT) line.

OmniTrans is the local transit operator for the San Bernardino Valley, providing bus service throughout the jurisdictions and also into parts of Los Angeles and Riverside counties. The Long Range Transit Plan delineates an extensive future bus rapid transit system in the Valley. The E Street sbX line will run from California State University – San Bernardino south into downtown San Bernardino, and Loma Linda, with termination near the University of Redlands. Other routes throughout the Valley are being considered as well. Foothill Transit is the operator of bus service in the eastern portion of Los Angeles County (primarily the San Gabriel Valley) with some lines going into San Bernardino County.

While LA/Ontario International Airport is the primary airport for the Inland Empire, San Bernardino International Airport (SBD) is expected to provide passenger service at some point in the future. Currently SBD serves major freight airlines as well as firefighting duties for the United State Forest Service. Cable Airport, Chino Airport, and Redlands Municipal Airport are general aviation airports also located in the San Bernardino Valley.

### **2.1.2 Victor Valley and Barstow**

Victor Valley and the Barstow area are located north of the San Bernardino Valley and connected to it by I-15 through the Cajon Pass,. Although less urban than the cities to the south, the jurisdictions of the Victor Valley have seen much development since the turn of the century. The Victor Valley subarea contains the cities of Adelanto, Hesperia, Victorville, and the Town of Apple Valley. Figures 2-3 and 2-4 provide mapping for the Victor Valley and Barstow areas, respectively.

Although not as developed as the San Bernardino Valley, the Victor Valley has a number of locations for shopping such as the Victorville Mall, Village Center, and the Victor Plaza Shopping Center. Barstow has a cluster of outlet shopping centers designed principally for the passing traveler on I-15, along with more local use stores in its downtown. The Marine Corps Logistics Base and Burlington Northern/Santa Fe railroad facilities are major employment locations. Victor Valley College and Barstow Community College are major educational institutions located in Victorville and Barstow,

respectively. Public transportation in the Victor Valley is provided by the Victor Valley Transit Authority, while Barstow Area Transit serves Barstow and its surrounding areas.

The Southern California Logistics Airport (SCLA) in Victorville is primarily used for the transport of overseas goods in and out of the Southern California region. This important center for logistics is also used for military troop transport and firefighting planes for the California Department of Forestry. There are also several general aviation airports in this subarea: Apple Valley Airport, Baker Airport, Barstow-Dagget Airport, and Hesperia Airport.

### **2.1.3 Morongo Basin**

Nestled near Joshua Tree National Park is the Morongo Basin. Surrounded by the vast expanse of the Mojave Desert, the Morongo Basin subarea is ideal for bicycling, both for recreation and commuting. The Town of Yucca Valley and the City of Twentynine Palms are located within the subarea, along with the unincorporated areas of Joshua Tree and Morongo Valley. Figure 2-5 provides mapping for the Morongo Basin.

Communities in the Morongo Basin are lower density in terms of residential and commercial activities. Most of the commercial activity is focused along State Route 62. SR-247 provides connectivity to the north. The local marine base, Marine Corps Air Ground Combat Center in Twentynine Palms, provides yearlong training to new recruits and thus is a strong and stable part of the local economy.

Jurisdictions in the Morongo Basin are served by public transportation through the Morongo Basin Transit Authority. There are several general aviation airports in the Morongo Basin, including: Twentynine Palms Airport, Yucca Valley Airport, and Roy Williams Airport.

### **2.1.4 Mountains**

The Mountains subarea is located north and east of the San Bernardino Valley. It offers much in terms of recreational activities with its easy access to skiing resorts and Big Bear Lake. The only incorporated jurisdiction is that of the City of Big Bear Lake, though there are many unincorporated areas nearby, such as Big Bear City and Lake Arrowhead. Figure 2-6 provides mapping for the Mountain subarea.

The Mountains subarea is an active recreational area, particularly for winter sports. Communities in the Bear Valley subarea are centered on providing services and retail accommodations to visitors. Additionally, its location in the San Bernardino National Forest provides dozens of hiking and off-road trails. The backbone highway network consists largely of State highways, requiring Caltrans to play an active role in any accommodations considered for non-motorized facilities.

The Mountain Area Regional Transit Authority provides bus service to residents and visitors in the areas around Big Bear Lake, including service down the mountain to the East Valley. Big Bear City Airport is a general aviation airport just outside the city limits of the City of Big Bear Lake.

### **2.1.5 Colorado River Basin**

Located along the Colorado River, this subarea contains the City of Needles and abuts Arizona to the east. Although it has limited population, the Colorado River Basin provides ample opportunities for



recreation and outdoor activities. The area is also home to a satellite campus of Palo Verde Community College in Needles. Figure 2-7 provides mapping for the Colorado River Basin subarea.

Needles Area Transit provides public transportation to Needles and surrounding communities. The Chemehuevi Valley Airport is a general aviation airport located approximately eighteen miles south of Needles.

## **2.2 Goals**

The infrastructure improvements and programs recommended in the San Bernardino County for the NMTP will be shaped by the Plan's goals and policies. Goals provide the context for the specific policies discussed in the NMTP. The goals provide the long-term vision and serve as the foundation of the Plan. Goals are broad statements of purpose, while policies identify specific initiatives and provide implementation direction on elements of the Plan.

The following represent the goals of the NMTP:

1. Increased bicycle and pedestrian access - Expand bicycle and pedestrian facilities and access within and between neighborhoods, to employment centers, shopping areas, schools, and recreational sites.
2. Increased travel by cycling and walking - Make the bicycle and walking an integral part of daily life in San Bernardino County, particularly (for bicycle) for trips of less than five miles, by implementing and maintaining a bikeway network, providing end-of-trip facilities, improving bicycle/transit integration, encouraging bicycle use, and making bicycling safer and more convenient.
3. Routine accommodation in transportation and land use planning - Routinely consider bicyclists and pedestrians in the planning and design of land development, roadway, transit, and other transportation facilities, as appropriate to the context of each facility and its surroundings.
4. Improved bicycle and pedestrian safety - Encourage local and statewide policies and practices that improve bicycle and pedestrian safety.

## **2.3 Policies**

A set of policy recommendations was approved the SANBAG Plans and Programs Committee in October 2009 and reconfirmed in February 2011. The policies are as follows:

1. Local jurisdictions are the agencies responsible for the identification of non-motorized transportation projects within their jurisdiction for inclusion into the Plan. SANBAG shall only serve in an advisory capacity with respect to the identification of projects on the regional network. SANBAG shall provide advice on the inclusion of projects that may serve to better establish connectivity between jurisdictions, intermodal facilities and regional activity centers. However, local jurisdictions have sole authority over all projects included in the Plan
2. Local jurisdictions are also responsible for implementation of the projects included in the NMTP. SANBAG may provide advisory support to jurisdictions in the project development

process on request. Should SANBAG be requested to provide assistance delivering a project in the Plan, such instances should be limited to development of regional non-motorized transportation facilities that provide connectivity to more than one jurisdiction or complete gaps within the regional non-motorized transportation network or serve to provide better access to transit facilities.

3. SANBAG shall, when feasible, support local education and safety efforts currently being implemented through local law enforcement, highway patrol, Caltrans and schools to better educate children and adults on the safe use of bicycles and to promote the non-motorized transportation system.
4. SANBAG shall prepare and update the comprehensive map identifying the County's non-motorized transportation system using its in-house GIS capabilities. Maintenance of the maps is also an important element of SANBAG's proposed 511 Traveler Information System.
5. SANBAG shall work with its member agencies to develop a regional way-finding system to assist travelers to identify the non-motorized transportation system. Any such system developed shall be developed in collaboration with local jurisdictions, will afford an opportunity for member agency customization, and promote connectivity to transit facilities, park and ride lots, and other regional activity centers.
6. SANBAG shall work with and encourage member agencies to incorporate non-motorized transportation facilities into general and specific plans as well as provide assistance in identifying design standards that provide for pedestrian- and bicycle-friendly access to transit facilities.
7. SANBAG shall use the NMTP as one component of the overall strategy to reduce greenhouse gas emissions pursuant to SB 375.
8. SANBAG shall work with and encourage transit operators to provide end-of-trip pedestrian and bicycle-serving facilities, such as bike lockers, racks, and capacity on transit vehicles to carry bicycles and better facilitate the integration and use of non-motorized transportation within the regional transportation system.
9. SANBAG shall use this plan as the basis to allocate state, federal, and local funds for delivery of non-motorized transportation improvements. Fund types may include, but are not limited to, federal Transportation Enhancement (TE), Congestion Mitigation and Air Quality (CMAQ), state Bicycle Transportation Account (BTA), and Transportation Development Act (TDA) Article 3 funds.
10. SANBAG shall work with member agencies to coordinate delivery of the NMTP and projects contained in the Nexus Study.
11. SANBAG shall work with member agencies to identify state/federal bicycle and pedestrian infrastructure or planning grant opportunities. When funding opportunities arise, SANBAG shall work to support local jurisdiction grant applications or collaborate with local jurisdictions to directly submit grant applications for projects in the Plan.
12. SANBAG and member agencies shall conduct regular bicycle and pedestrian counts to monitor the effects of implementation of the NMTP. SANBAG shall work to identify funding for the monitoring of Class I, separated shared-use facilities, so that no financial impact is borne

by the local jurisdictions for collection of count information. Counts conducted on Class II and Class III, on-street bicycle facilities, shall correspond with counting for intersections that are both on the non-motorized network and require CMP Monitoring as outlined in the Congestion Management Program. When counts for non-CMP intersections are desired, SANBAG shall be responsible for identifying funding for such counts.

These policies constitute a modest expansion of SANBAG's role in implementing the NMTP. Most of the policy recommendations are incorporated into SANBAG's current activities, although they may not be explicitly stated. All of the proposed policies are consistent with the agency's role as a County Transportation Commission and a Council of Governments. Moreover, SANBAG programs significant state, federal and local funding sources to implement the components of the NMTP, and needs to play an active role in providing for regional non-motorized transportation from that perspective as well.

## 3.0 Bicycle Planning

The specific recommendations of the NMTP include bicycle facility development such as the completion of a regional bikeway network, provision of end-of-trip facilities, development of a regional way-finding system, and support of educational and promotional programs to be implemented over the next twenty years. These are listed more specifically at the end of Chapter 3. Three sections lead up to the listing of these recommendations:

- 3.1 – Classes of Bikeways
- 3.2 – Types of Bicycle Riders
- 3.3 – Estimates of Commuter Bicycle Trips
- 3.4 – Existing Bicycle Network
- 3.5 – Future Bicycle Network
- 3.6 – Recommendations for the Regional Bikeway System

### 3.1 Classes of Bikeways

San Bernardino County jurisdictions have made substantial progress in providing at least basic bicycle facilities in most of its subregions. All bikeways adhere to the standards described by the Caltrans Design Manual, the American Association of State Highway Transportation Officials (AASHTO) Guidelines for the Development of Bicycle Facilities, and the Manual of Uniform Traffic Control Devices (MUTCD) published by Federal Highway Administration. There are three classes of bikeways, as described below:

- **Class I Bikeway (Shared Use Path or Bike Path):** A bikeway physically separated from any street or highway. Shared Use Paths may also be used by pedestrians, skaters, wheelchair users, joggers, and other non-motorized users. For an example, see the figure immediately below.



Figure 3.1 – Class I Bikeway Information

- **Class II Bikeway (Bike Lane):** A portion of roadway that has been designated by striping, signaling, and pavement markings for the preferential or exclusive use of bicyclists. For an example, see the graphics immediately below.



Figure 3.2 – Class II Bikeway Information

- **Class III Bikeway (Bike Route):** A generic term for any road, street, path, or way that in some manner is specifically designated for bicycle travel regardless of whether such facilities are designated for the exclusive use of bicycles, or are to be shared with other transportation modes. For an example, see the graphics immediately below.

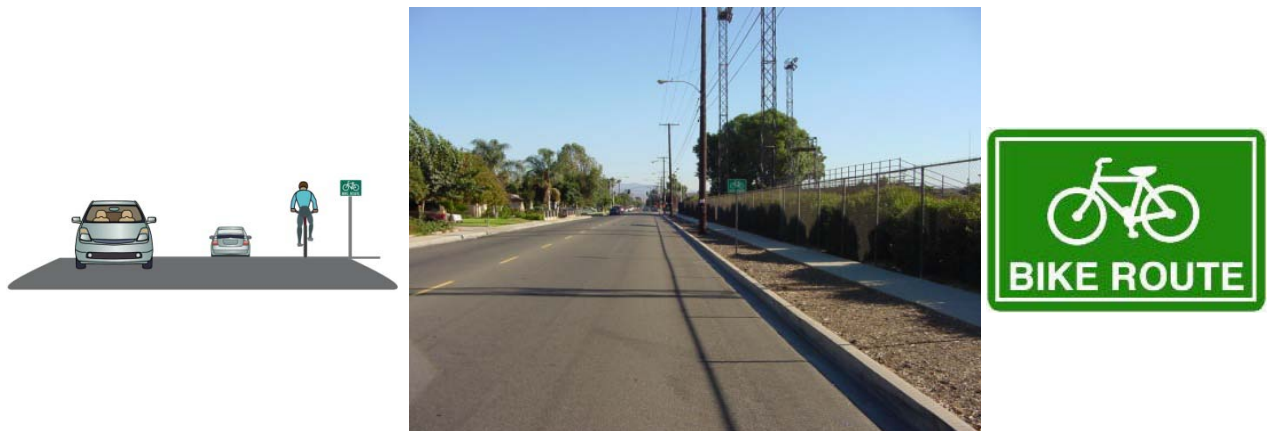

Figure 3.3 – Class III Bikeway Information

- **Signed Shared Roadway or Signed Bike Route:** A shared roadway that has been designated by signing as a preferred route for bicycle use. These are Class III facilities under the Caltrans Design Standards.

- **Class IV Bikeway (Separated Bikeway):** A Class IV bikeway is for the exclusive use of bicycles and includes a required separation between the bikeway and the through vehicular traffic. The separation may include, but is not limited to, grade separation, flexible posts, inflexible posts, inflexible barriers, or on-street parking. For an example, see the graphics immediately below.



Figure 3.4 – Class IV Separated Bikeway Information

## 3.2 Types of Bicycle Riders

Despite the advances various cities have made in facilitating bicycling, many individuals still have concerns about the safety of bicycle transportation. Other bikeway plans have used a typology to categorize riders based on their approach to bicycling. A brief description of the four types can be found in below.

Of course there are limitations to any model that puts individuals into categories. The four types are not intended to be rigid characterizations but rather provide insight into potential cycling market segments. A major premise of this plan is that the residents who are described as ‘interested but concerned’ will not be attracted to bicycle for transportation by the provision of more bike lanes, but may be more willing to ride if a network of low-stress bikeways is provided.

### 3.2.1 Type 1 - Strong and Fearless

This type of bicyclist (about 1 or 2 percent) will ride anywhere, regardless of the bicycle facility or lack thereof. They are comfortable on busy roads without bike lanes and may – in many circumstances – prefer to have no bicycle facilities at all.

### 3.2.2 Type 2 - Enthused and Confident

These bicyclists (about 10 percent) are comfortable on busy streets with bike lanes. They are the group that responds to many miles of bike lanes by riding.



### 3.2.3 Type 3 - Interested but Concerned

‘Interested but concerned’ bicyclists (about half) include the vast majority of County residents. They may occasionally ride on trails or bicycle boulevards, while on vacation or on an organized group ride. ‘Interested but concerned’ residents would like to ride more, but are reluctant because they do not feel safe near fast-moving traffic on busy streets, even when bike lanes exist. They would ride if they felt more comfortable on the roadways due to fewer and slower-moving cars or if more car-free alternatives were available.

### 3.2.4 Type 4 - Not Interested

This type includes approximately a third of residents, who are not going to ride a bicycle for transportation, either because they are uninterested or unable to do so.

## 3.3 Estimates of Commuter Bicycle Trips

County-level estimates of commuting by bicycle were presented in Chapter 1. City-level estimates of commute trips by bicycle within San Bernardino County are shown in Table 3-1. These statistics are drawn from the American Community Survey, over the period of 2006-2009. The statistics were derived from a survey sample, not the entire population, but were expanded to represent the entire population. Statistics for the unincorporated areas of the County are not included.

The table shows that the percentage of commute trips by bicycle is very low, only 0.4% overall. Only the City of Big Bear Lake had a percentage of greater than 1%. The cities with the highest percentages in the Valley were Chino, Loma Linda, and Redlands.

**Table 3-1. City-level Percentage of Daily Commuter Trips by Bicycle  
(Source: American Community Survey, 2006-2009)**

CITY	TOTAL COMMUTE TRIPS	% TRIPS BY BICYCLE
Adelanto	4,650	0.86%
Apple Valley	19,360	0.05%
Barstow	7,880	0.32%
Big Bear Lake	2,365	1.06%
Chino	26,470	0.81%
Chino Hills	31,770	0.17%
Colton	18,355	0.27%
Fontana	46,235	0.21%
Grand Terrace	5,790	0.43%
Hesperia	21,960	0.39%
Highland	16,595	0.30%

Loma Linda	8,090	0.80%
Montclair	12,250	0.65%
Needles	1,650	0.61%
Ontario	60,920	0.61%
Rancho Cucamonga	60,635	0.21%
Redlands	29,335	0.84%
Rialto	31,540	0.17%
San Bernardino	60,600	0.50%
Twentynine Palms	6,180	0.65%
Upland	31,570	0.25%
Victorville	22,025	0.45%
Yucaipa	1,7035	0.23%
Yucca Valley	5,735	0.00%
TOTAL	548,995	0.40%

Selected California cities were also analyzed as a basis of comparison against statistics for cities in San Bernardino County. For example, Santa Barbara has one of the higher rates at 3.1% of commuting trips by bicycle. This might be thought of as an aggressive goal for some of the cities in San Bernardino County such as Redlands and Loma Linda, each of which has a college/university as a major focal point. Davis, California, which has an extraordinary emphasis on cycling, still has a bicycle commuting percentage of less than 10 percent. The City of Sacramento is marginally over 1 percent. It would be significant achievement for San Bernardino County to double its bicycle commuting percentage over the next 20 years.

### 3.4 Existing Bicycle Network

#### 3.4.1 Overview

San Bernardino County has some excellent non-motorized facilities already in place for both recreation and commuting. The following describes these assets in detail and their relationship to the NMTP.

The growth of the non-motorized system has been substantial during the past decade. In 2001, the combined total of centerline miles of bicycle infrastructure for all jurisdictions was 53 miles. As of 2011, the combined total of centerline miles of bicycle infrastructure for all jurisdictions is 468 miles. This represents an increase of 415 centerline miles and a 780% growth in the County's bicycle infrastructure.

Subarea maps of existing and proposed bicycle facilities are provided in Figures 3-4 through 3-10. The full set of maps may be referenced at the end of this chapter. Additional information and tabular summaries of existing and proposed route mileage are provided for each individual jurisdiction in Chapter 5.

### **3.4.2 Existing Regional Non-Motorized Assets**

San Bernardino County has some excellent non-motorized facilities already in place for both recreation and commuting. The following describes these assets and their relationship to the NMTP.

#### **Pacific Electric Trail**

The Pacific Electric Trail is a shared use path for bicyclists and pedestrians located in the San Bernardino Valley. Once used as a right-of-way for the Pacific Electric Rail Line and bought by SANBAG, this path traverses cities in both Los Angeles and San Bernardino counties. Currently the path is paved from Pomona College in Claremont to the eastern city boundary of Fontana. Rialto is planning on extending it further east.

#### **Santa Ana River Trail**

Stretching from the Pacific Ocean in Huntington Beach to the Inland Empire, the Santa Ana River Trail is a long Class I Bikeway that connects three counties along the Santa Ana River. The current terminus of the trail is in the Hospitality District of San Bernardino, but plans are underway to extend it into Redlands and Highland.

#### **Flood Control Channels**

There are various flood control channels throughout the County. Through an agreement with the Flood Control District of San Bernardino County's Department of Public Works, bicyclists are allowed to use the access roads adjacent to flood control channels when gates are open. These roads are considered Class I bikeways or share use paths and are an excellent and safe option for the bicycle commuter or enthusiast.

#### **Power Line Corridors**

Similar to the flood control channels, paved access roads next to large power lines are legal for cyclists' use when not in use by utility workers or officials from Southern California Edison or the Los Angeles Department of Water and Power. There is no danger of radiation or electrical hazard by bicyclists or pedestrians under power lines.

#### **Cajon Pass Connector – Route 66 Heritage Trail**

Although not yet fully realized as a complete Class I Bikeway, the Cajon Pass Connector will someday connect the Victor Valley to the San Bernardino Valley via the Cajon Pass. Once complete, this bikeway will provide a seamless and safe method of bicycle transportation from the Glen Helen area to State Route 138 on the Historic Route 66 (Cajon Boulevard).

#### **Orange Blossom Rail Trail**

Just like the Cajon Pass Connector, the Orange Blossom Rail Trail is an incomplete Class I Bikeway. With sufficient funding and planning, this bikeway through Redlands will provide exceptional multimodal connectivity to the nearby Santa Ana River Trail and the planned Redlands Rail.

## End-of-Trip Facilities and Bicycle Connections to Transit

Figures 2-1 through 2-7 identified locations of significant bicycle trip destinations. Most of these locations include bicycle racks. Bike lockers exist at several Metrolink stations in San Bernardino County. Selected office buildings may provide showers and facilities to change and store clothes, but the specific locations have not been documented at a comprehensive level. See Chapter 5 local plans for more specific info on end-of-trip facilities. In addition, all Omnitrans buses provide two bicycle racks for easy access/egress of the bus system by cyclists. Metrolink trains allow bicycles to be stowed on-board. This will also be true of the future Bus Rapid Transit network in the City of San Bernardino.

### 3.5 Future Bicycle Network

In addition to the above-mentioned existing regional assets that span across cities, many jurisdictions have developed their own Class I, Class II, and/or Class III bikeways. Collectively, these represent the bikeways portion of the NMTP. Figures 3-4 through 3-10 showcase these future facilities at the subarea level. Table 3-2 summarizes the total centerline mileage of existing and planned bicycle network by class. These mileage totals represent a summation of those in the individual jurisdiction plans. Because some of the planned facilities represent conversions from one class to another, the total existing plus planned is a slight over-counting of the actual mileage expected when the plan is complete.

**Table 3-2. Summary of Existing and Planned Bicycle Network Centerline Mileage**

(Note: Total existing plus planned represents a slight over-representation of the future network totals – see text.)

	Class I	Class II	Class III	Total
Existing	78.1	270.1	116.3	464.5
Planned	277.9	756.6	247.6	1282.1
Total	356.0	1026.7	363.9	1746.6

The local jurisdiction plans in Chapter 5 are drawn from the subarea maps and provide a more detailed discussion on specific bikeway facilities, end-of-trip facilities, and project priorities, where appropriate. Chapter 6 addresses design considerations when implementing bicycle facilities. Chapter 7 presents an overall implementation strategy and priorities.

### 3.6 Recommendations for the Regional Bikeway System

Specific project lists, recommendations, and priorities are contained in the individual jurisdiction bicycle plans in Chapter 5. This section provides recommendations that are regional in nature, with emphasis on the physical infrastructure in San Bernardino County. Chapter 7 presents an implementation strategy that takes these a step further, and provides regional priorities.

1. Deliver the Class I, II and III identified in the subarea maps referenced in Chapter 3. Although the Class I facilities can be considered a backbone bicycle system, there is much more to the network than just Class I facilities. Other types of facilities can also be delivered more quickly and less expensively, improving regional connectivity.

2. Develop better bicycle connectivity between cities and subareas of the County by coordinating the location and staging of network improvements. This must include improved collaboration with Caltrans, given the number of State highways connecting the subareas. Connectivity on Class II and Class III bicycle facilities can be increased by prioritizing the “low-hanging fruit” – parts of the regional system that are low-cost, close gaps in the system, and provide connections to key destinations.
3. Develop a better “sense of a system” through improved signage, markings, and way-finding for both cyclists and pedestrians.
4. Develop an improved inventory of end-of-trip facilities, particularly at transit stations, schools, other public buildings, and major employment centers.
5. Proactively coordinate integration of cycling and walking accommodations with the State’s Complete Streets requirements.
6. Proactively coordinate integration of cycling and walking access accommodations to and from transit stations.
7. Continue safety education and promotion of cycling through schools, newsletters, and public websites.

## 4.0 Pedestrian Planning

---

### 4.1 Issues in Pedestrian Access and Mobility

It is often perceived that pedestrian transportation is essentially a local concern, given the length of most pedestrian trips and the manner in which these trips are usually contained within a given area, whether that area is a schoolyard, a shopping center, a college campus or a downtown business district.

At the same time, federal legislation and funding programs reminds us that regional, state and federal levels of government all have a stake in designing the multi-modal transportation system to serve the needs of all travelers. It is often said that pedestrian planning is a part of “alternative transportation planning,” yet there is no more basic mode of transportation than getting around on foot. Indeed, no trip involving a car, bus, train, airplane or other mode can even begin without a pedestrian journey taking place. Regional transportation facilities such as airports and transit stations must be designed around the needs of the pedestrian if they are to fulfill their mission.

Unfortunately, as American society moved to develop the systems necessary to accommodate the automobile, many of the values associated with pedestrian transportation have been diminished, if not lost. This is not a phenomenon unique to Southern California. As highway and street design standards have evolved over the past fifty years, the problems of insufficient pedestrian access, diminished safety and difficult trip making have been repeated across the country.

City-level statistics on commute trips by walking within San Bernardino County bear this out, as shown in Table 4-1. The percentage of commute trips by walking are drawn from the American Community Survey, over the period of 2006-2009. The statistics were derived from a survey sample, not the entire population, but were expanded to represent the entire population. Statistics for the unincorporated areas of the County are not included.

The table shows that the percentage of commute trips by walking is very low, less than 1% overall. Some of the smaller communities actually show larger walk trip shares, presumably because the work locations and homes are fewer and therefore in closer proximity. However, caution should be exercised in reading too much into the data for the cities with smaller sample sizes. Loma Linda has the highest walk trip percentage in the Valley, at 2.3%. This is consistent with presence of the large hospital and educational complex in Loma Linda. The City of Redlands was next, with 1.7% of commute trips by walking. The City of Big Bear Lake was shown to have the largest walk trip percentage at 7%.

It is not possible for a single regional plan to either identify all the liabilities and shortcomings of the pedestrian environment or to plan and fund their correction. Many of the issues and concerns are appropriately addressed at the local or even neighborhood level. At the same time, this plan can identify priorities for the use of regionally administered funds to meet common regional needs.

For purposes of this plan, the following activities are considered regional priorities for pedestrian planning and project development:



1. Improving pedestrian access to transit;
2. Removing existing barriers to pedestrian travel;
3. Development of regional trails and pathways which provide improved pedestrian access to destinations;
4. Improvement of the pedestrian environment on major regional arterials and at regional activity centers.

**Table 4-1. City-level Percentage of Daily Commuter Trips by Walking  
(Source: American Community Survey, 2006-2009)**

<b>CITY</b>	<b>TOTAL COMMUTE TRIPS</b>	<b>% TRIPS BY WALKING</b>
Adelanto	4,650	1.6%
Apple Valley	19,360	0.8%
Barstow	7,880	2.7%
Big Bear Lake	2,365	7.0%
Chino	26,470	1.4%
Chino Hills	31,770	0.3%
Colton	18,355	1.0%
Fontana	46,235	0.6%
Grand Terrace	5,790	0.2%
Hesperia	21,960	0.2%
Highland	16,595	0.5%
Loma Linda	8,090	2.3%
Montclair	12,250	1.2%
Needles	1,650	4.2%
Ontario	60,920	0.8%
Rancho Cucamonga	60,635	0.6%
Redlands	29,335	1.7%
Rialto	31,540	0.9%
San Bernardino	60,600	1.4%
Twentynine Palms	6,180	1.2%
Upland	31,570	1.0%
Victorville	22,025	0.3%
Yucaipa	1,7035	0.6%
Yucca Valley	5,735	1.0%
<b>TOTAL</b>	<b>548,995</b>	<b>0.9%</b>

## **4.2 Regional Pedestrian Facility Programs**

The following program concepts describe potential elements of a regionally based pedestrian transportation effort:

### **4.2.1 Transit Access**

One of the most significant regional benefits of improved pedestrian access and safety involves the support of local and regional transit systems. All transit agencies rely heavily on pedestrian access as a core of their ridership base, indeed, public transit is a safety net for those citizens who do not have access to an automobile.

It is critical that this core customer base have access to transit service, yet in many, if not most areas of San Bernardino County, there are few efforts being made to ensure that pedestrians have systems which promote safety, continuity, connectivity and accessibility. Local jurisdictions should work cooperatively with transit agencies to assess walking conditions within 600 – 1200 feet of any transit stop. Most transit patrons are willing to walk at least this distance if facilities are present and safe. Local transit systems also have an interest in working with local jurisdictions to ensure that there is an ADA compatible access route to all transit stops, including pads adequate in size to accommodate wheelchair loading systems while maintaining a clear walking path.

In addition, land use codes can do much to ensure that new development serves the needs of transit. In new residential subdivisions, care should be taken to ensure that pedestrians can walk within a reasonable distance to access local transit service. This can be provided by including “pass-through” pathways between cul-de-sac streets and adjacent arterials. While many residential developments minimize vehicular access in an effort to cut down local “cut-through” traffic, these same developments must maintain good pedestrian access to destinations within and adjacent to the development.

Commercial development also can provide a significantly more amenable environment for pedestrians through careful site planning. Orientation of business entrances to the street can make for a quicker pedestrian trip from transit to destination, while inclusion of overhangs, shade, and shelter near transit stops can make for improved and pleasant waiting times for transit patrons. Many communities encourage development of businesses such as newsstands, coffee shops and cafes near major transit stops and centers to make these facilities more active, safer and more pleasant.

A significant initiative of SANBAG and local jurisdictions is to plan for more walkable communities within and around transit station areas. This is being accomplished through the development of the Sustainable Communities Strategy (SCS), which will become part of the SCAG Regional Transportation Plan. The SCS is looking at better ways to plan land use around transit stations and to provide ped/bike connectivity and amenities that encourage non-motorized modes. The SANBAG Long Range Transit Plan provides mapping of existing and future transit alignments and station areas around which this planning may occur. A map of the future LRTP system was presented in Chapter 1.

## 4.2.2 Preventing and Eliminating Barriers to Pedestrian Travel

Planning for improved pedestrian access is relatively simple, but often overlooked. One needs to simply think about the directions/destinations from/to which people are walking and determine how to accommodate those paths. This is best done at the “prevention stage” through good site planning, to include both internal and external pedestrian circulation. It is more difficult and costly to eliminate barriers once they are there.

But the stage can be set with some overarching principles and guidelines. The document *PEDSAFE: Pedestrian Safety Guide and Countermeasure Selection System* (Federal Highway Administration report FHWA-SA-04-003, September 2004) provides many examples of pedestrian design treatments suitable for use throughout San Bernardino County. Chapter headings include:

- Pedestrian Facility Design: Sidewalks and Walkways, Curb Ramps
- Roadway Design: Bicycle Lanes, Roadway Narrowing, Lane Reduction
- Intersection Design: Roundabouts, Intersection Median Barriers
- Traffic Calming: Curb Extensions, Chicanes, Speed Tables

Information on PEDSAFE may be found at the following link:

<http://www.fhwa.dot.gov/research/deployment/pedsafe.cfm>

## 4.2.3 Development of Regional Trails and Pathways

From the pedestrian perspective, the development of trails and pathways can provide an important supplement to other local efforts and systems to improve pedestrian facilities. Such facilities, to have a significant pedestrian benefit, must connect numerous destinations and trip origins within reasonable walking distance, provide a unique access not afforded by other street and sidewalk systems and should be a more pleasant and safer place to walk than other existing alternatives.

Many trails utilize existing corridors such as abandoned rail lines, power corridors, pipelines and even limited access rights of way. Other communities have built smaller walkways through downtown areas through dedication of a narrow strip easement on one property edge, allowing development of a pathway system to occur over time as properties develop in a business district.

## 4.2.4 Providing a Better Pedestrian Environment on Major Regional Arterials and at Activity Centers

Clearly, a number of strong regional and local interests converge at locations with high activity, whether the activity is in the form of auto traffic, pedestrians, or where many business and employers locate. From the regional perspective, the improvement of these corridors and districts can assist transit agencies, business development districts and traditional downtowns.

Many examples exist of improvements to Main Street districts throughout the County. New business developments seek to create a vibrant, busy sense of place in indoor malls and centers; trying ultimately to replicate the environment of the successful downtown street. Such districts are an important amenity to support regional transit efforts, as concentrations of activity allow transit to effectively serve larger numbers of commuters, shoppers and visitors with a more efficient system.

While there are many examples of pedestrian malls that have developed in Southern California in the past 40 years, it is not necessary or obligatory to ban automobiles entirely to create a more attractive downtown or business district. While successful projects such as the 3<sup>rd</sup> Street Promenade in Santa Monica do exist, similarly successful projects have retained auto access while simultaneously created more pleasant pedestrian environments through expansion of walkways, introduction of more street level activity, preservation of street trees and shade and the promotion of activities such as street fairs and farmers markets to create the energy needed to make these districts a commercial as well as transportation success.

# 5.0 Local Jurisdiction Plans

---

## 5.1 Overview

Chapter 5 represents the heart of the Non-Motorized Plan for bicycle facilities. The chapter contains individualized plans for each of the 25 jurisdictions in San Bernardino County, with emphasis on the bicycle system. The plans all contain the same structure, including the following elements:

- The 2013 total population of the jurisdiction according to the Department of Finance.
- An overview of the jurisdiction, including uniquely tailored commentary about its geography or historical elements.
- A summary of the jurisdiction's existing and proposed land use.
- A map of the jurisdiction's General Plan land use coverage, including information on schools, parks, residential, commercial and industrial land uses.
- A map of the jurisdiction's existing and proposed bicycle facility networks.
- A textual description of the existing non-motorized condition.
- A textual description of the jurisdiction's past investment in non-motorized infrastructure
- A textual description of the jurisdiction's non-motorized priorities, if any.
- Tables that document existing, future and priority bicycle facility projects with class, mileage, and estimated costs.
- A summary table of multi-modal connections.
- Documentation of municipal code pertaining to the provision of non-motorized serving infrastructure, if available.
- A summary of non-motorized serving infrastructure, including bike racks, bike lockers and shower facilities where identified.
- A table with collision information and an analysis as to how the number of collisions relates to the state average.
- Information on jurisdiction safety and education programs related to non-motorized transportation.

One important note while reviewing the local jurisdiction plans relates to the costs used. The cost estimates used to value existing improvements and the cost estimates used to project the cost of future improvements are planning level costs based on a rounded cost per mile assumption. The cost assumption used for Class I facilities is \$1,000,000 per mile, the cost assumption used for Class II facilities is \$50,000 per mile and the cost assumption for Class III facilities is \$15,000 per mile. These cost assumptions were derived from a review of other similar plans and a review of construction averages for the State of California. The cost assumption for Class IV varied with jurisdictions as they reported them since only a few locations are thinking of implementing this Class; for planning only then, these costs are approximated at \$2,000,000 per mile.

All cost estimates are planning level, and do not include feasibility, environmental clearance or right-of-way acquisition. Project-specific factors such as grading, landscaping, intersection modification, path/trail amenities and right-of-way acquisition may increase the actual cost of construction, sometimes significantly. The estimates are primarily used to develop an understanding for the order of magnitude of investment that will be required to implement the plan.

## 5.2 Local Jurisdiction Plans

The remainder of this chapter presents local jurisdiction non-motorized transportation plans, with an emphasis on bicycle facilities and statistics. The plans are presented in alphabetical order by jurisdiction. Each plan begins on a new page. The following jurisdictions are represented:

- City of Adelanto
- Town of Apple Valley
- City of Barstow
- City of Big Bear Lake
- City of Chino
- City of Chino Hills
- City of Colton
- City of Fontana
- City of Grand Terrace
- City of Hesperia
- City of Highland
- City of Loma Linda
- City of Montclair
- City of Needles
- City of Ontario
- City of Rancho Cucamonga
- City of Redlands
- City of Rialto
- City of San Bernardino
- City of Twentynine Palms
- City of Upland
- City of Victorville
- City of Yucaipa
- Town of Yucca Valley
- County of San Bernardino
- SANBAG



## City of Adelanto

### **Population**

31,289

### **City Overview**

Incorporated in 1970, the City of Adelanto is located in the California High Desert, approximately 35 miles north of San Bernardino and approximately 60 miles northeast of Los Angeles. The City is located northwest of the City of Victorville and immediately west of the former George Air Force Base.

### **Land Use**

The City of Adelanto is one of San Bernardino County's biggest incorporated municipalities in terms of land area with just over 53.5 square miles of land area. The City has a tremendous amount of developable land remaining, including but not limited to areas designated for residential, commercial, office, industrial, and airport development. US Route 395 serves as the major north-south arterial roadway and Air Expressway serves as the major east-west arterial roadway within the City.

### **Existing Conditions:**

There are currently no designated bicycle facilities within the City of Adelanto.

#### *Growth/Past investment in system*

Since the San Bernardino County Non-Motorized Transportation Plan was first prepared in 2001, the City of Adelanto has not constructed any designated bicycle infrastructure improvements within the City.

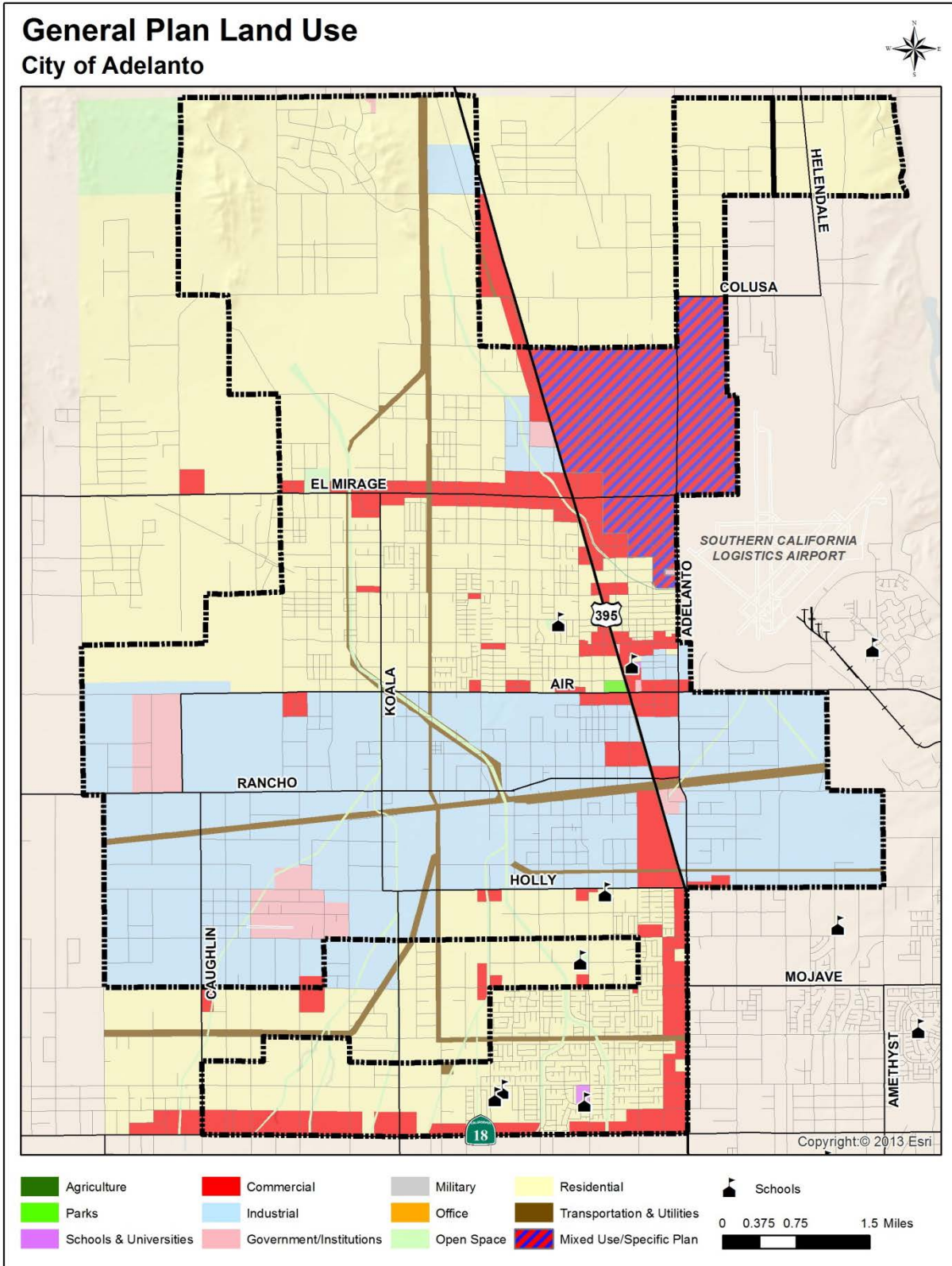

Figure 5.1

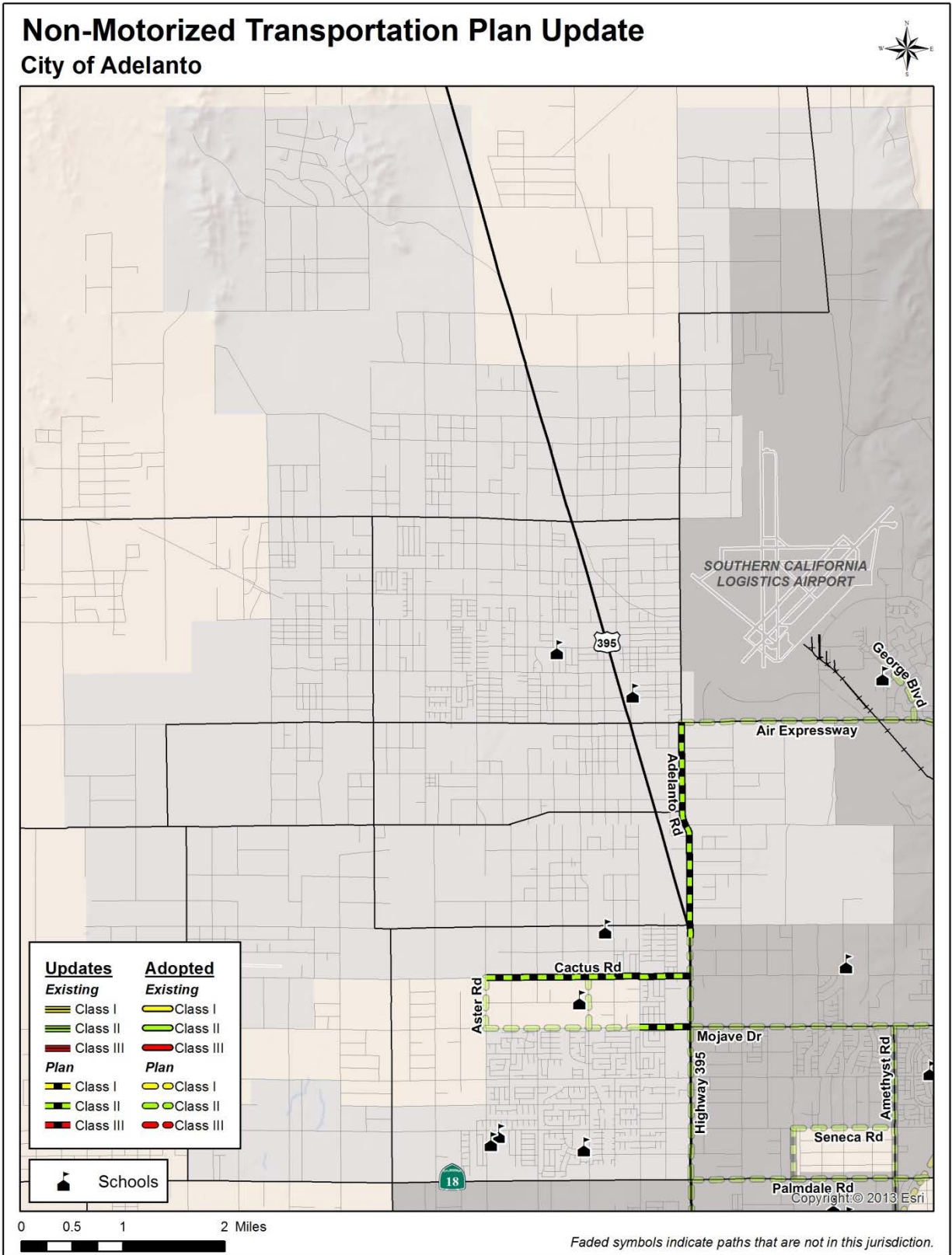

Figure 5.2

Table 5.1

Adelanto Existing Conditions

Street/Path	From	To	Class	Length (mi.)	Cost Estimate
n/a	n/a	n/a	n/a	n/a	n/a
			<b>Total</b>	<b>n/a</b>	<b>n/a</b>

**Proposed Improvements**

Table 5.2

Adelanto Future Improvements

Street/Path	From	To	Class	Length (mi.)	Cost Estimate
Adelanto Rd.	Air Expressway	0.12mi. S Holly Rd.	II	2.13	\$106,500
Mojave Dr.	Mesquite Rd.	Highway 395	II	0.50	\$25,000
Cactus Rd.	Aster Rd.	Highway 395	II	2.01	\$100,500
			<b>Total</b>	<b>4.64</b>	<b>\$232,000</b>

**Municipal Code**

The City of Adelanto adopted Ordinance 130 in 1978 per the Municipal Code section 10.36.030, which established a City-wide bicycle trail system and associated design standards. The purpose of the system was to establish a long range plan for the City that would encourage the development and use of bicycles for commuter-oriented transportation. The ordinance has not been updated since 1978. The city is examining the potential of reviewing the ordinance and amending it to reflect the changes that have impacted the circulation design of the City since 1978 and incorporating additional safety and esthetic design changes to enhance the non-motorized facilities.

**End of Trip Facilities**

The City of Adelanto has bike racks dispersed throughout the City, typically at retail centers, schools and multi-unit housing complexes. The City of Adelanto also possesses bicycle lockers at its City Hall.

**Multimodal Connectivity**

Table 5.3

Location of Multi-Modal Connections

Facility	Facility Type	Facility Location
City-wide Bus Stops	Bus Stops	Throughout City

**Collisions Involving Bicyclists**

Table 5.4

Data for Collisions Involving Bicyclists

Parameter	Collision Rate
Total # of Bicycle Collisions from 2007-2011	9
Total # of Bicycle Fatalities from 2007-2011	0
Total # of Bicycle Injuries from 2007-2011	7
Average # of Bicycle Collisions Per Year	1.8
Average Bicycle Collision Rate per 1000/year <sup>1</sup>	0.08

Notes:

1. Rate is calculated using SWITRS collision data and population figures by the California Department of Finance

**Safety and Education Programs**

The City of Adelanto does not participate in safety or education programs specific to non-motorized transportation or the placement of non-motorized transportation facilities.

## Town of Apple Valley

### **Population**

73,984

### **Town Overview**

The Town of Apple Valley is located in the heart of the Victor Valley in the County of San Bernardino. As one of the municipalities comprising the "High Desert," Apple Valley is located 95 miles northeast of the Los Angeles metropolitan area, 140 miles north of San Diego, and 185 miles south of Las Vegas. The Town has 78 square miles in its incorporated boundaries, and a sphere of influence encompassing 200 square miles. Clean air, the backbone to a robust non-motorized network, and open spaces permits Apple Valley to be an opportune area to reach destinations by means other than the automobile.

### **Land Use**

The map in Figure 5.3 shows the current and future land use patterns in the Town of Apple Valley. The land use types in Apple Valley are all related to a single, over-arching concept: that Apple Valley's quality of life is tied to its rural character, and that this character is to be preserved and protected for the long term health of the community. In Apple Valley "rural" means space — unscarred mountains and vistas of desert valleys, neighborhoods of large lots where keeping horses is allowed, an extensive multi-use trail system, and landscaping consistent with the desert environment.

### **Existing Conditions:**

Three types of bicycle lanes exist within the Town of Apple Valley. Existing bicycle lanes (Class II facilities) are used to promote greater connectivity and access throughout the community, and encourage non-motorized modes of travel. Bicycles lanes in the Town of Apple Valley are also designed to connect to regional bikeways (Class I facilities). Currently, 13.53 miles of Class I, and 24.16 miles of Class II facilities are part of the Town's existing circulation system.



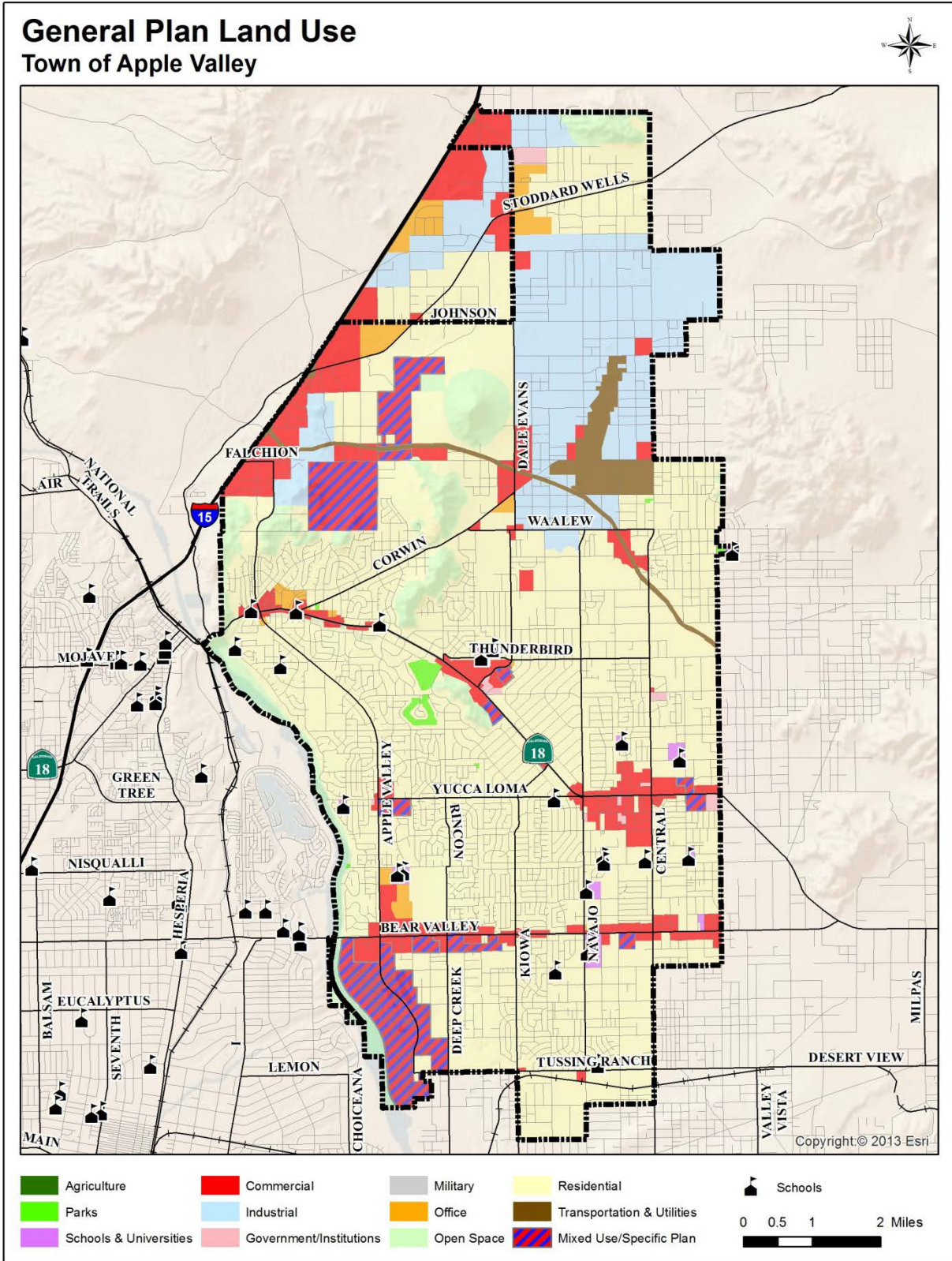

Figure 5.3

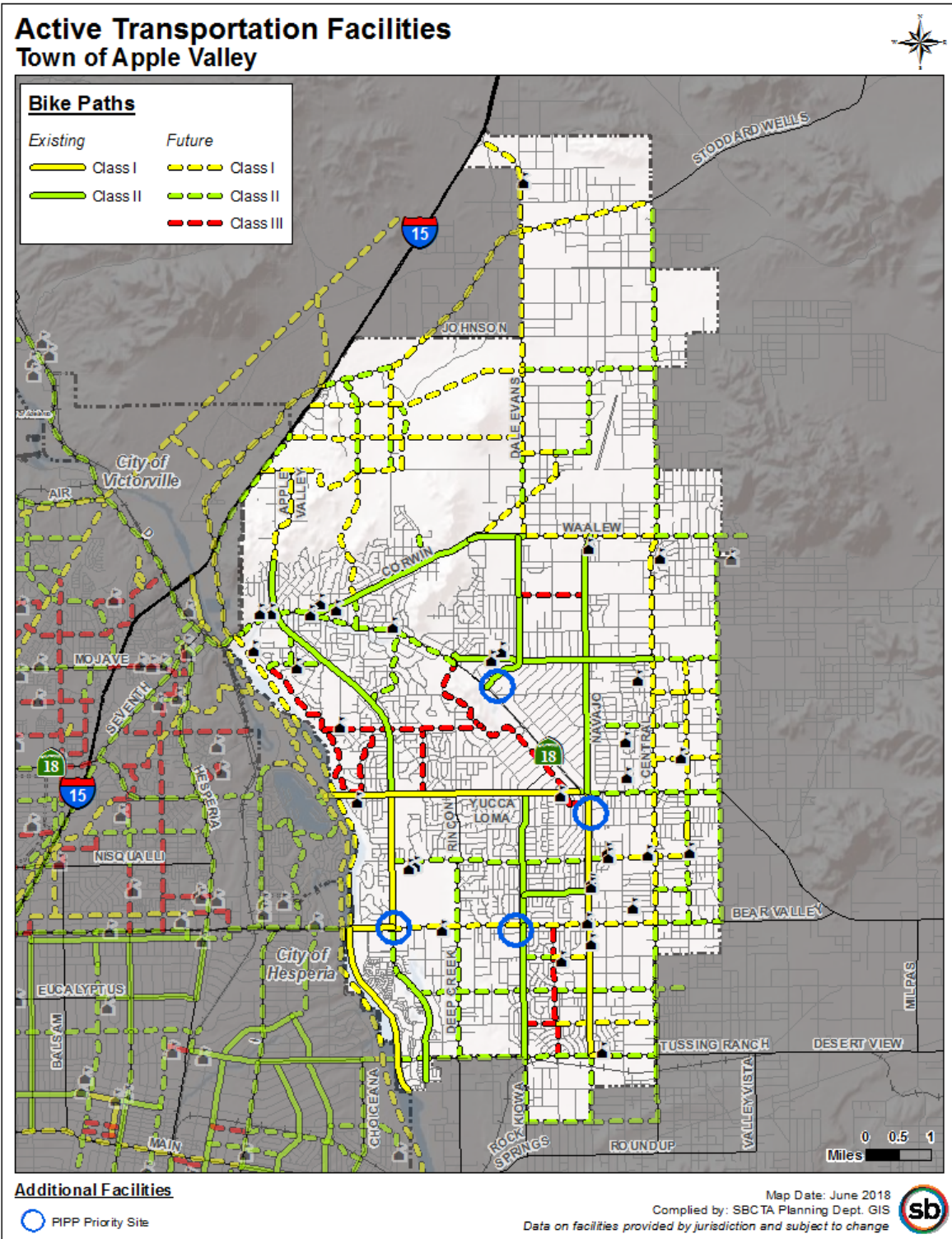

Figure 5.4

Table 5.5

Apple Valley Existing Conditions

Street/Path	From	To	Class	Length (mi.)	Cost Estimate
Apple Valley Rd.	Jess Ranch Pkwy.	Verbena St.	II	1.77	\$88,500
Apple Valley Rd.	Ohna Rd.	Yucca Loma Rd.	II	4.27	\$213,500
Apple Valley Rd.	Yucca Loma Rd.	Bear Valley Rd.	I	2.01	\$2,010,000
Bear Valley Rd.	Mojave River	Apple Valley Rd.	I	0.70	\$700,000
Corwin Rd.	SR-18	Waalew Rd.	II	2.78	\$139,000
Dale Evans Pkwy.	Otoe Rd.	SR-18	II	1.67	\$83,500
Dale Evans Pkwy.	Waalew Rd.	Otoe Rd.	II	0.89	\$44,500
Kiowa Rd.	Bear Valley Rd.	Tussing Ranch Rd.	II	2.00	\$100,000
Kiowa Rd.	Yucca Loma Rd.	Bear Valley Rd.	II	2.02	\$101,000
Mesquite Rd.	Lucilla Rd.	Ottawa Rd.	I	0.21	\$210,000
Mojave Riverwalk South	Bear Valley Rd.	South City Limit	I	2.72	\$960,000
Navajo Rd.	SR-18	Tussing Ranch Rd.	I	4.00	\$4,000,000
Navajo Rd.	Waalew Rd.	SR-18	II	3.90	\$195,000
Pah-Ute Rd.	Kiowa Ave.	Navajo Rd.	II	1.01	\$50,500
Thunderbird Rd.	Rancherias Rd.	Central Rd.	II	3.03	\$151,500
Tussing Ranch Rd.	Navajo Rd.	Cochiti Rd.	I	0.29	\$290,000
Waalew Rd.	Corwin Rd.	Dale Evans Pkwy.	II	0.82	\$41,000
Yucca Loma Rd.	Mojave River	Algonquin Rd.	I	3.60	\$3,600,000
			<b>Total</b>	<b>37.69</b>	<b>\$12,978,000</b>

*Growth/Past investment in system*

Since the San Bernardino County Non-Motorized Transportation Plan was first prepared in 2001, the Town of Apple Valley has constructed 13.53 miles of Class I and 24.16 miles of Class II facilities at a rate of over 2.0 miles per year.

*Past Investment in Non-Motorized Infrastructure*

The improvements included in Table 5.5 above constitute a significant investment into the non-motorized transportation infrastructure of Apple Valley. Based on planning level estimates, the value of the improvements implemented throughout the Town is \$12,978,000.

**Proposed Improvements**

Future improvements to the non-motorized network for the Town of Apple Valley will continue along the major transportation corridors throughout the Town. All proposed future improvements are included in Table 5.6 below. The total of the future investment proposed in Apple Valley non-motorized infrastructure is estimated to be \$54,585,250.



Table 5.6

Apple Valley Proposed Improvements

Street/Path	From	To	Class	Length (mi.)	Cost Estimate
Alembic St.	Norco St.	Falchion Rd.	II	0.50	\$25,000
Alembic St.	Stoddard Wells Rd.	Norco St.	I	1.06	\$1,060,000
Apple Valley Rd.	Bear Valley Rd.	Jess Ranch Pkwy.	II	0.74	\$37,000
Apple Valley Rd.	Falchion Rd.	Ohna Rd.	I	1.49	\$1,490,000
Bear Valley Rd.	Central Rd.	Joshua Rd.	II	1.00	\$50,000
Bear Valley Rd.	W City Limit	Central Rd.	I	3.98	\$3,980,000
Central Rd.	Bear Valley Rd.	Mojave St.	II	2.62	\$131,000
Central Rd.	Stoddard Wells Rd.	Waalew Rd.	II	5.08	\$254,000
Central Rd. <sup>A</sup>	Waalew Rd.	Bear Valley Rd.	I	6.26	\$6,260,000
Choco Rd.	Saugus Rd.	Norco St.	II	0.55	\$27,500
Choco Rd.	Seneca Rd.	Yucca Loma Rd.	III	1.00	\$15,000
Choco Rd.	Waalew Rd.	Corwin Rd.	II	0.42	\$21,000
Corwin Rd.	Choco Rd.	Dakota Rd.	I	2.50	\$2,500,000
Dakota Rd.	Fresno Rd.	Corwin Rd.	I	0.34	\$340,000
Dale Evans Pkwy.	Corwin Rd.	Waalew Rd.	I	0.55	\$550,000
Dale Evans Pkwy.	Fresno Rd.	Corwin Rd.	II	0.72	\$36,000
Dale Evans Pkwy.	Outer I-15 S	Fresno Rd.	I	4.99	\$4,990,000
Deep Creek Rd.	Sitting Bull Rd.	Tussing Ranch Rd.	II	3.00	\$150,000
Del Oro Rd.	Apple Valley Rd.	Denison Rd.	II	4.09	\$204,500
Esaws Ave.	Central Rd.	Joshua Rd.	I	1.00	\$1,000,000
Falchion Rd.	Outer I-15 S	Norco St.	I	2.84	\$2,840,000
Fresno Rd.	Dachshund Ave.	Navajo Rd.	II	0.50	\$25,000
Fresno Rd.	Dale Evans Pkwy.	Dachshund Ave.	I	0.51	\$510,000
Havasu Rd.	Seneca Rd.	Yucca Loma Rd.	III	1.09	\$16,350
Highway 18.	W. Town Limit	Apple Valley Rd.	II	0.82	\$41,000
Kiowa Rd.	Tussing Ranch Rd.	Ocotillo Way	II	1.00	\$50,000
Lafayette St.	Dale Evans Pkwy.	Central Rd.	II	2.02	\$101,000
Mandan Rd.	Hwy 18	Apple Valley Rd.	II	1.29	\$64,500
Mesquite Rd.	Lucilla Rd.	Bear Valley Rd.	II	1.29	\$64,500
Mesquite Rd.	Yucca Loma Rd.	Ottawa Rd.	II	0.50	\$25,000
Mohawk Rd.	Bear Valley Rd.	Tussing Ranch Rd.	III	1.99	\$29,850
Mojave Riverwalk North	6th St.	Bear Valley Rd.	I	4.97	\$5,450,000
Navajo Rd.	Lafayette St.	Fresno Rd.	II	1.27	\$63,500
Navajo Rd.	Tussing Ranch Rd.	Ocotillo Way	II	1.00	\$50,000
Nisqually Rd.	Maumee Rd.	Mesquite Rd.	I	1.17	\$1,170,000
Nisqually Rd.	Navajo Rd.	Maumee Rd.	II	0.33	\$16,500
Norco St.	Outer I-15 S	Dale Evans Pkwy.	I	3.55	\$3,550,000
Ocotilla Rd.	Thunderbird Rd.	Yucca Loma Rd.	I	2.00	\$2,000,000
Ocotillo Way	Kiowa Rd.	Navajo Rd.	II	1.00	\$50,000
Otoe Rd.	Dale Evans Pkwy.	Navajo Rd.	III	1.01	\$15,150
Outer Hwy 18 N	Apple Valley Rd.	Tao Rd.	II	1.23	\$61,500
Outer Hwy 18 S	Navajo Rd.	Joshua Rd.	II	2.00	\$100,000
Outer Hwy 18 S	Tao Rd.	Mandan Rd.	II	1.61	\$80,800
Outer I-15 S	Stoddard Wells Rd.	Norco St.	II	2.15	\$107,500

Street/Path	From	To	Class	Length (mi.)	Cost Estimate
Pah-Ute Rd.	Central Rd.	Mesquite Rd.	II	0.50	\$25,000
Pauma St.	Saugus Rd.	Falchion Rd.	II	1.00	\$50,400
Pauma St.	Stoddard Wells Rd.	Saugus Rd.	II	0.46	\$23,000
Powhatan Rd.	Rancherias Rd.	Navajo Rd.	III	0.29	\$4,350
Ramona Ave.	Navajo Rd.	Ocotilla Rd.	II	1.50	\$75,000
Rancherias Rd.	Hwy 18	Powhatan Rd.	III	3.34	\$50,100
Rancherias Rd.	Thunderbird Rd.	Hwy 18	III	0.12	\$1,800
Riverside Dr.	Symeron Rd.	Havasu Rd.	III	2.68	\$40,200
Sandia Rd.	Kiowa Rd.	Mohawk Rd.	II	0.45	\$22,500
Sandia Rd.	Mohawk Rd.	Navajo Rd.	I	0.55	\$550,000
Saugus Rd.	Outer I-15 S	Dale Evans Pkwy.	I	3.31	\$3,310,000
Seneca Rd.	Riverside Dr.	Rancherias Rd.	III	2.38	\$35,700
Sitting Bull Rd.	Apple Valley Rd.	Navajo Rd.	II	3.00	\$149,800
Standing Rock Ave.	Central Rd.	Joshua Rd.	I	1.00	\$1,000,000
Stoddard Wells Rd.	Alembic St.	Johnson Rd.	I	0.70	\$700,000
Stoddard Wells Rd.	Dale Evans Pkwy.	Central Rd.	I	2.07	\$2,070,000
Stoddard Wells Rd.	Outer I-15 S	Alembic St.	II	1.07	\$53,500
Symeron Rd.	Riverside Dr.	Apple Valley Rd.	II	0.88	\$44,000
Tao Rd.	Corwin Rd.	Outer Highway 18	II	0.48	\$23,750
Tao Rd.	Falchion Rd.	Corwin Rd.	I	2.05	\$2,050,000
Thunderbird Rd.	Central Rd.	Joshua Rd.	II	1.00	\$50,000
Tuscola Rd.	Apple Valley Rd.	Symeron Rd.	II	0.45	\$22,500
Tussing Ranch Rd.	Cochiti Rd.	Central Rd.	II	0.71	\$35,500
Tussing Ranch Rd.	Mojave River	Navajo Rd.	II	2.90	\$145,000
Waalew Rd.	Central Rd.	Joshua Rd.	II	0.90	\$45,000
Waalew Rd.	Corwin Rd.	Dale Evans Pkwy.	I	2.89	\$2,890,000
Wren St.	Kiowa Rd.	Mohawk Rd.	III	0.50	\$7,500
Wren St.	Mohawk Rd.	Central Rd.	I	1.50	\$1,500,000
Yucca Loma Rd.	Algonquin Rd.	Navajo Rd.	II	0.15	\$7,500
			<b>Total</b>	<b>117.86</b>	<b>\$54,585,250</b>

TABLE NOTES – <sup>A</sup>: Street currently has a designated bike path meeting local standards only, therefore not included under “Existing” conditions table of this Plan

Table 5.7

Priority Improvements

Street/Path	From	To	Class	Length (mi.)	Cost Estimate
n/a	n/a	n/a	n/a	n/a	n/a
			<b>Total</b>	<b>n/a</b>	<b>n/a</b>

The Town of Apple Valley has not identified priority improvements.

**Pedestrian Facilities**

The City has also identified opportunities to enhance pedestrian facilities. These are described in *The Town of Apple Valley Safe Routes to School Master Plan: 2016-2017 (TAV SRTS)* and in the *2017 SBCTA Points of Interest Pedestrian Plan (PIPP)*. The *TAV SRTS* focuses on improving access to neighborhood schools, and as a locally adopted plan it's not outlined here, while the *PIPP* focuses on improving access to other community assets listed in Table 5.8. Specific improvement recommendations per project are detailed in the *PIPP* for items in Table 5.8. To view the recommendations related to improving access to neighborhood schools, please consult with the Town.

Table 5.8

PIPP Opportunities

Project	Potential Connection to Bikeways, by Status and Class, within ¼ Mile of Project	Proposed Project Ranking
Kiowa Plaza Shopping Center	Existing Class II & Planned Class I	1
James A. Woody Community Center & Parks	Existing Class I & Planned Class III	2
Apple Valley Town Hall & Civic Facilities	Existing Class II	3
Bear Valley & Apple Valley Retail	Existing Class I & Planned Class I, II	4
Antelope Valley High School	Existing Class I & Planned Class I	NR <sup>A</sup>
Granite Hills High School	Planned Class I	NR <sup>A</sup>
Norm Schmidt Park	None	NR <sup>A</sup>

TABLE NOTES – <sup>A</sup>: NR = “Not Ranked”, listed as potential project locations and not included in above map.



## **Municipal Code**

The Town of Apple Valley Municipal Code provides minimal requirements and direction for the incorporation of non-motorized facilities in new development. Nevertheless, to encourage the use and provide for the opportunity of non-motorized transportation, the Town's Off-Street Parking and Loading Regulations may require bicycle parking for such uses as fast-food restaurants, theaters, shopping centers, schools, etc. or as determined by the Planning Division. A rack or other secure devices for the purposes of storing and protecting bicycles from theft is required.

## **General Plan Goals and Policies**

The Town's General Plan Circulation Element identifies goals and policies that relates to facilitating the use of non-motorized transportation.

### **Policy 1.J**

The Town shall implement a coordinated and connected bicycle lane network consistent with the Bicycle Lane Map in this Element.

#### **Program 1.J.1**

New development proposals shall be required to construct bicycle lanes consistent with this Element in conjunction with off-site improvements.

#### **Program 1.J.2**

The Town shall inventory bicycle lane deficiencies within the existing roadway system, and include improvements to make these improvements consistent with this Element in the Capital Improvement Program.

### **Policy 1.K**

The Town shall provide for a comprehensive, interconnected recreational trails system suitable for bicycles, equestrians and/or pedestrians.

#### **Program 1.K.1**

The Town shall evaluate the practicality of utilizing flood control channels for multi-use trails, where flooding and safety issues can be accommodated, and negotiate inter-agency agreements for this purpose.

#### **Program 1.K.2**

New development proposals shall be required to construct recreational trails consistent with this Element in conjunction with off-site improvements.

The Town's General Plan Park and Recreation Element also identifies goals and policies that relate to facilitating the use of non-motorized transportation.

## **Goal 2**

Expansion and further development of an integrated and comprehensive bikeway, walking paths and trails system that includes effective signage and supporting facilities to encourage use.

**Policy 2.A**

In addition to connecting homes to schools, the trails system will connect residential areas to commercial centers, workplaces and recreational facilities.

**Policy 2.B**

The Town’s bicycle lane network shall be maintained and expanded to encourage greater use and to improve the safety of bicyclists on town streets.

**Program 2.B.1**

Installation of bikeways shall be included in the Capital Improvement Program and the Town shall inventory all existing major arterial streets for potential to accommodate Class I and II bikeways.

**End of Trip Facilities**

The Town of Apple Valley has bike racks dispersed throughout the Town, typically at retail centers, schools and multi-unit housing complexes.

**Multimodal Connectivity**

Table 5.9

Location of Multi-Modal Connections

Facility	Facility Type	Facility Location
n/a	n/a	n/a

**Collisions Involving Bicyclists**

Table 5.10

Data for Collisions Involving Bicyclists

Parameter	Collision Rate
Total # of Bicycle Collisions from 2012-2016	14
Total # of Bicycle Fatalities from 2012-2016	1
Total # of Bicycle Injuries from 2012-2016	13
Average # of Bicycle Collisions Per Year	2.8
Average Bicycle Collision Rate per 1000/year <sup>1</sup>	0.04

Notes:

1. Rate is calculated using SWITRS collision data and population figures by the California Department of Finance

### **Safety and Education Programs**

The Town of Apple Valley holds an annual safety fair and bike rodeo, geared to K - 5th grades which promotes bicycle safety. Also, the promotion of bike use is part of the Town's Healthy Apple Valley program.

## City of Barstow

### **Population**

23,168

### **City Overview**

Located in the high desert in central San Bernardino County, the City of Barstow is located at the intersection of Interstates 15 and 40 at the mid-point between Los Angeles and Las Vegas. Incorporated as a city in 1947, Barstow has grown from a small railroad town to become a center for rail transportation, the defense industry, mining, and tourist retail businesses. Barstow is home to BNSF Railway and two factory outlet complexes at Tanger Outlet and Barstow Outlet Stores. The City also serves as the gateway to the U.S. Army National Training Center (Ft. Irwin), the Marine Corps Logistical Base – Nebo Annex, and NASA’s Goldstone Deep Space Network.

### **Land Use**

The City of Barstow’s provides for a number of land use types within its boundaries. Typically, most commercial/retail development is located adjacent to Interstates 15 and 40 and most of the industrial/warehouse development is located adjacent to the BNSF tracks, northwest of the railroad and south of State Route 58.

Vacant residential land is still plentiful and relatively inexpensive in Barstow. The development potential remains high in the City. There was an annexation at National Trails Highway and Lenwood Road that was approved by LAFCO in 2011 and additional annexations are anticipated.

### **Existing Conditions:**

There are currently no bicycle facilities in the City of Barstow.

#### *Growth/Past investment in system*

Since the San Bernardino County Non-Motorized Transportation Plan was first prepared in 2001, the City of Barstow has not constructed any bicycle infrastructure improvements within the City.

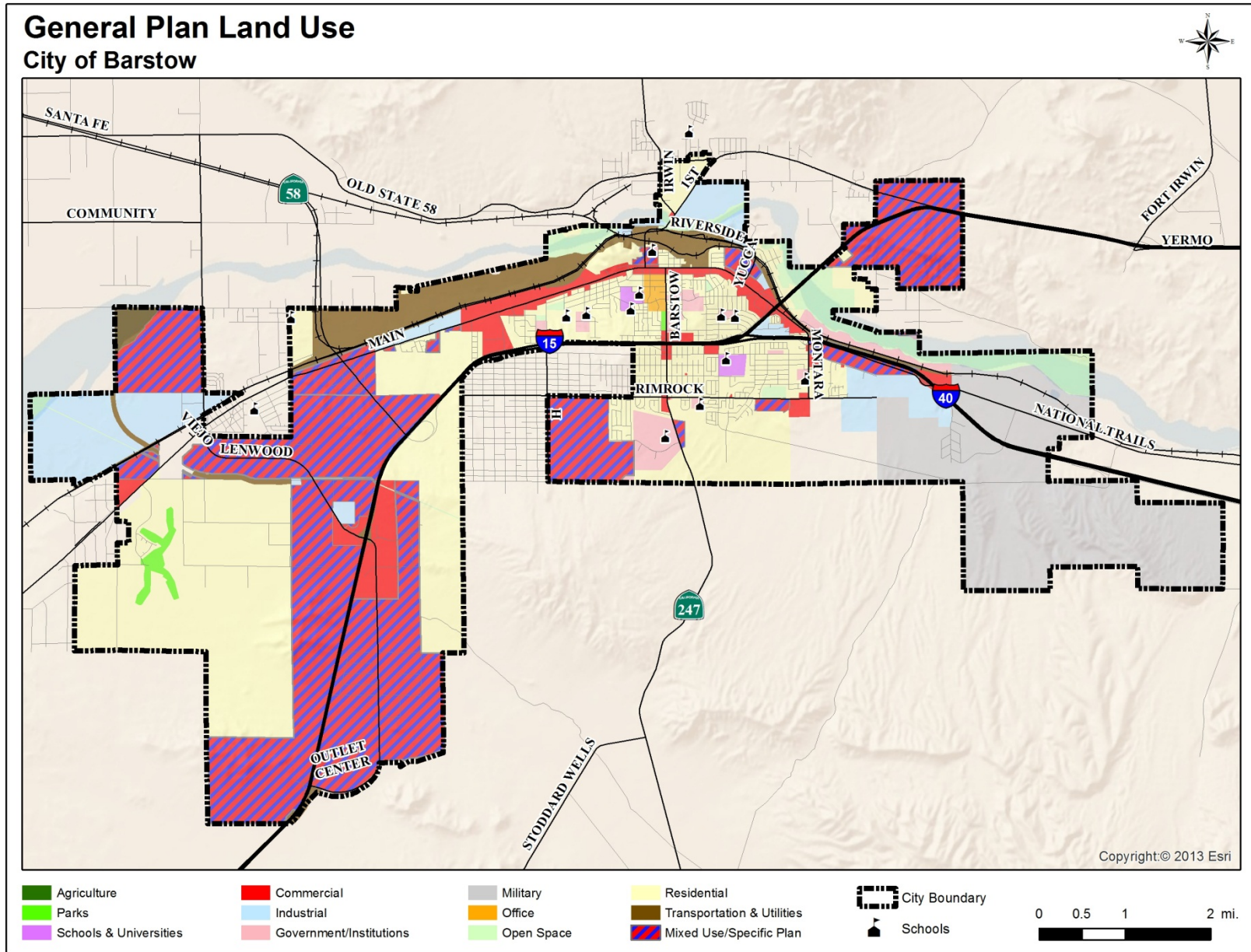

Figure 5.5



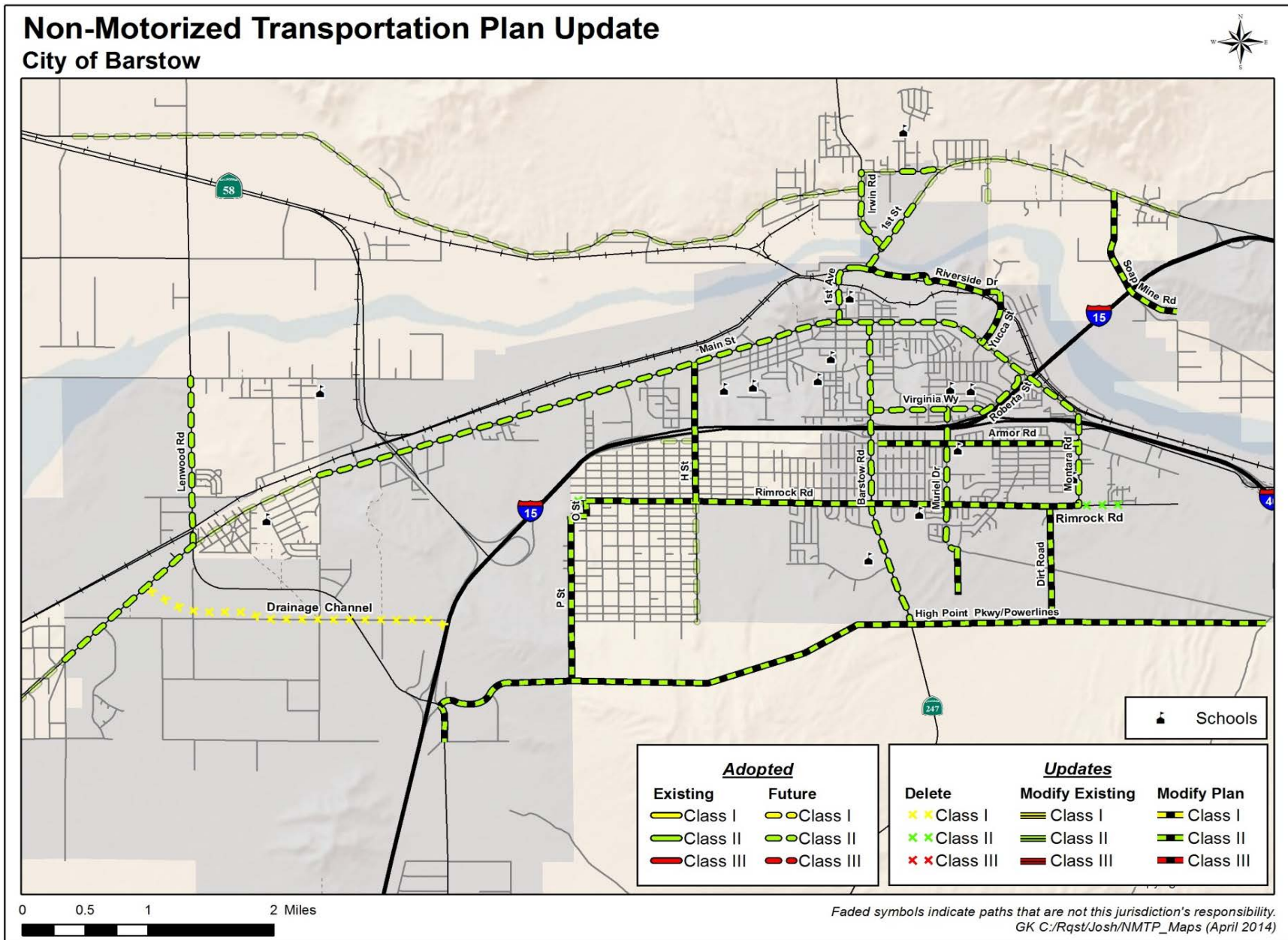

Figure 5.6

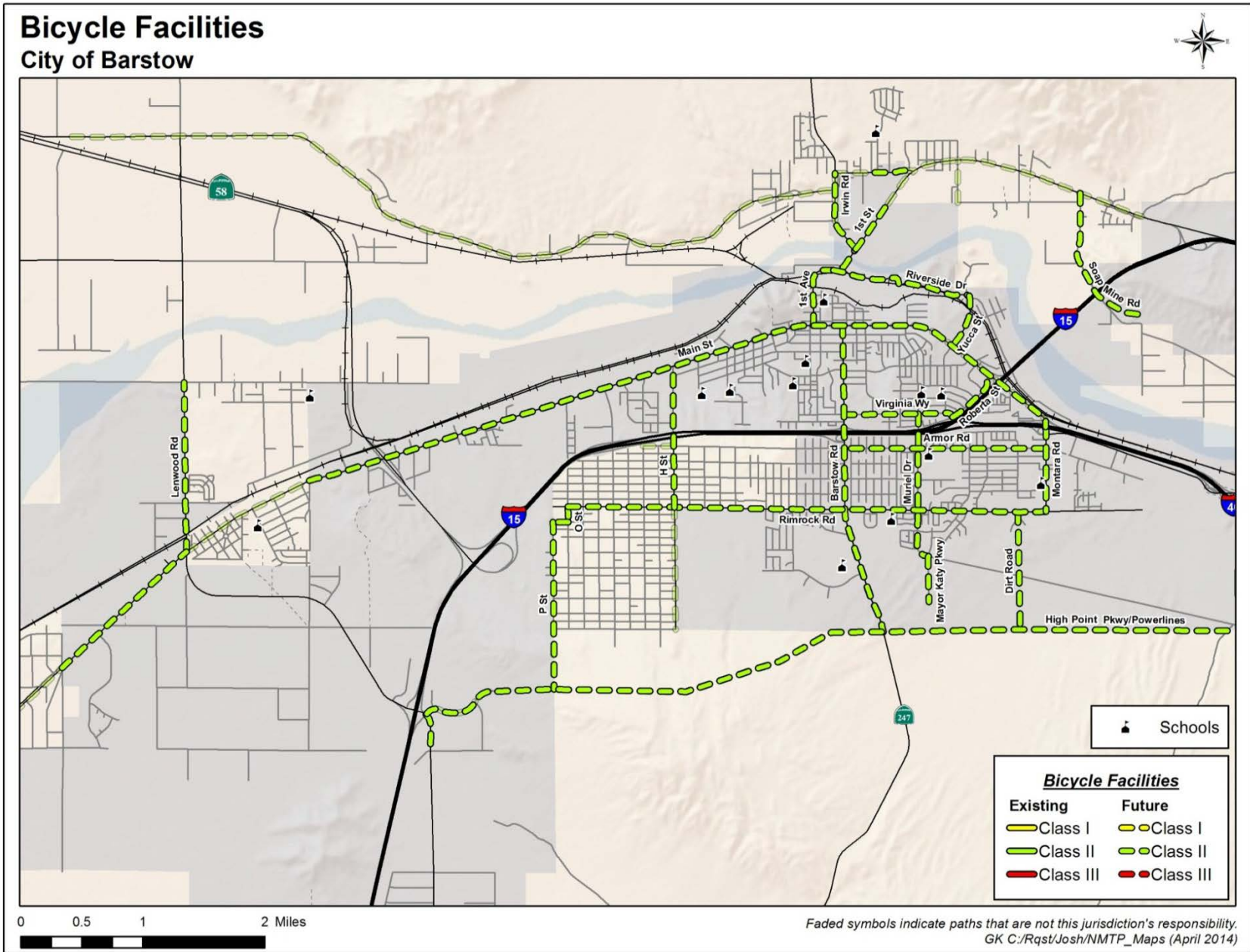



Table 5.11

Barstow Existing Conditions

Street/Path	From	To	Class	Length (mi.)	Cost Estimate
n/a	n/a	n/a	n/a	n/a	n/a
			<b>Total</b>	<b>n/a</b>	<b>n/a</b>

**Proposed Improvements**

Future improvements to the non-motorized network for the City of Barstow will develop along the major transportation corridors throughout the City as well as in some of the more remote and particularly scenic areas. A table of future improvements is included in Table 5.12 below.

Table 5.12

Barstow Proposed Improvements

Street/Path	From	To	Class	Length (mi.)	Cost Estimate
1st Ave.	Irwin Rd.	Main St.	II	0.85	\$42,500
1 <sup>s</sup> St.	Irwin Rd.	.46mi. NE Irwin Rd.	II	0.45	\$22,500
Armonr Rd.	Deseret Ave.	Montara Rd.	II	1.59	\$79,800
Azurite Rd.	P St.	O St.	II	0.12	\$6,250
Barstow Rd.	Main St.	SR-247	II	2.56	\$128,000
Dirt Road	Rimrock Rd.	Powerlines	II	0.96	\$480,100
H St.	Main St.	Rimrock Rd.	II	1.15	\$57,800
High Point Pkwy./Powerlines	Lenwood Ln.	Pipeline Rd.	II	6.76	\$338,050
Irwin Rd.	Old Hwy 58	1 <sup>st</sup> Ave.	II	0.79	\$39,500
Lenwood Rd.	Agate Rd.	Main St.	II	1.38	\$69,000
Lenwood Rd.	High Point Pkwy.	Mercantile Way	II	0.3	\$15,400
Main St.	Delaney Rd.	City Limit 0.68 mi. E	II	1.39	\$69,700
Main St.	W City Limit	I-40	II	6.62	\$331,000
Mayor Katy Pkwy.	Muriel Dr.	Sports Park	II	0.37	\$18,600
Montara Rd.	Main St.	Rimrock Rd.	II	0.62	\$31,000
Muriel Dr.	Virginia Way	Guadalupe Dr.	II	1.22	\$61,000
O St.	Rimrock Rd.	Azurite Rd.	II	0.12	\$6,300
Old State 58	0.02mi. W Camarillo Ave.	4m E Muriel St.	II	0.24	\$12,000
P St.	Azurite Rd.	Powerlines	II	1.37	\$68,550
Rimrock Rd.	O St.	Montara Rd.	II	3.92	\$196,000
Riverside Dr.	1 <sup>st</sup> Ave.	Yucca St.	II	1.18	\$59,250
Roberta St.	Virginia Way	Main St.	II	0.48	\$24,000
Soap Mine Rd.	Old State 58	Webster Rd.	II	1.28	\$64,100
Virginia Way	Barstow Rd.	Roberta St.	II	0.90	\$45,000
Yucca St.	Riverside Dr.	Main St.	II	0.45	\$22,700
			<b>Total</b>	<b>37.07</b>	<b>\$2,288,100</b>

The City of Barstow has identified Main Street, Barstow Road, H Street, Rimrock Road and Virginia Way as priority improvements. When all proposed projects are complete, the City will have constructed 37.07 miles of bicycle paths providing internal connectivity to the residents of Barstow, establishing interregional connections to the County highway system, and creating recreational paths that give residents and visitors an opportunity to improve their health and quality of life with a ride through the beautiful Barstow desert.

Table 5.13

Priority Improvements

Street/Path	From	To	Class	Length (mi.)	Cost Estimate
Barstow Rd.	Main St.	SR-247	II	2.56	\$128,000
H St.	Main St.	Rimrock Rd.	II	1.15	\$57,800
Main St.	I-40	W. City Limit	II	6.62	\$331,000
Rimrock Rd.	O St.	Granada Hills Ave.	II	3.92	\$196,000
Virginia Way	Barstow Rd.	Roberta St.	II	0.90	\$45,000
			<b>Total</b>	<b>15.15</b>	<b>\$757,800</b>

**Municipal Code**

As of March 2014, the City of Barstow is in the process of adopting a Municipal Code specific to non-motorized transportation including the placement of non-motorized transportation facilities.

**End of Trip Facilities**

The City of Barstow has bike racks dispersed throughout the City, typically at retail centers, schools and multi-unit housing complexes.

**Multimodal Connectivity**

The City of Barstow has the following multimodal facilities that interface with the non-motorized transportation system.

Table 5.14

Multimodal Connectivity

Facility	Facility Type	Facility Location
City-wide Bus Stops	Bus Stops	Throughout City

## Collisions Involving Bicyclists

Table 5.15

### Data for Collisions Involving Bicyclists

Parameter	Collision Rate
Total # of Bicycle Collisions from 2007-2011	20
Total # of Bicycle Fatalities from 2007-2011	1
Total # of Bicycle Injuries from 2007-2011	13
Average # of Bicycle Collisions Per Year	4.0
Average Bicycle Collision Rate per 1000/year <sup>1</sup>	0.18

Notes:

1. Rate is calculated using SWITRS collision data and population figures by the California Department of Finance

## Safety and Education Programs

The City of Barstow does not currently participate in any bicycle safety or education programs.

## City of Big Bear Lake

### **Population**

5,512

### **City Overview**

The City of Big Bear Lake is a four-season, resort community located approximately 25 miles northeast of the City of San Bernardino in the San Bernardino Mountains. The City encompasses almost seven square miles and is approximately seven miles long and two miles wide. The City adjoins Big Bear Lake, which is the largest recreational lake in Southern California.

The Big Bear Valley was settled in the 1860s following the discovery of gold in the area. In 1884, Big Bear Lake was formed with the construction of a dam to provide irrigation waters to the San Bernardino Valley. By the 1920s, recreation became the most important economic factor in the valley. The local economy continues to be primarily based on tourism, with the summer and winter months being the most heavily visited seasons.

### **Land Use**

The Big Bear Valley has historically been a weekend and second-home retreat for the residents of San Bernardino, Riverside and Los Angeles metropolitan areas. The City incorporated in 1980, in part as a response to these development pressures and the desire to have local control. The residents of the City express a strong desire to balance the benefits of growth with the preservation of the natural environment.

The land use of the City is comprised mostly of single-family residential, but also includes a number of areas designated for multi-family residential, commercial, service and industrial uses. The City's location adjacent to large areas of public lands, which are under the control of the U.S. Department of Forestry, provides for urban growth boundaries, preserving public open space and limiting urban sprawl.

# General Plan Land Use City of Big Bear Lake

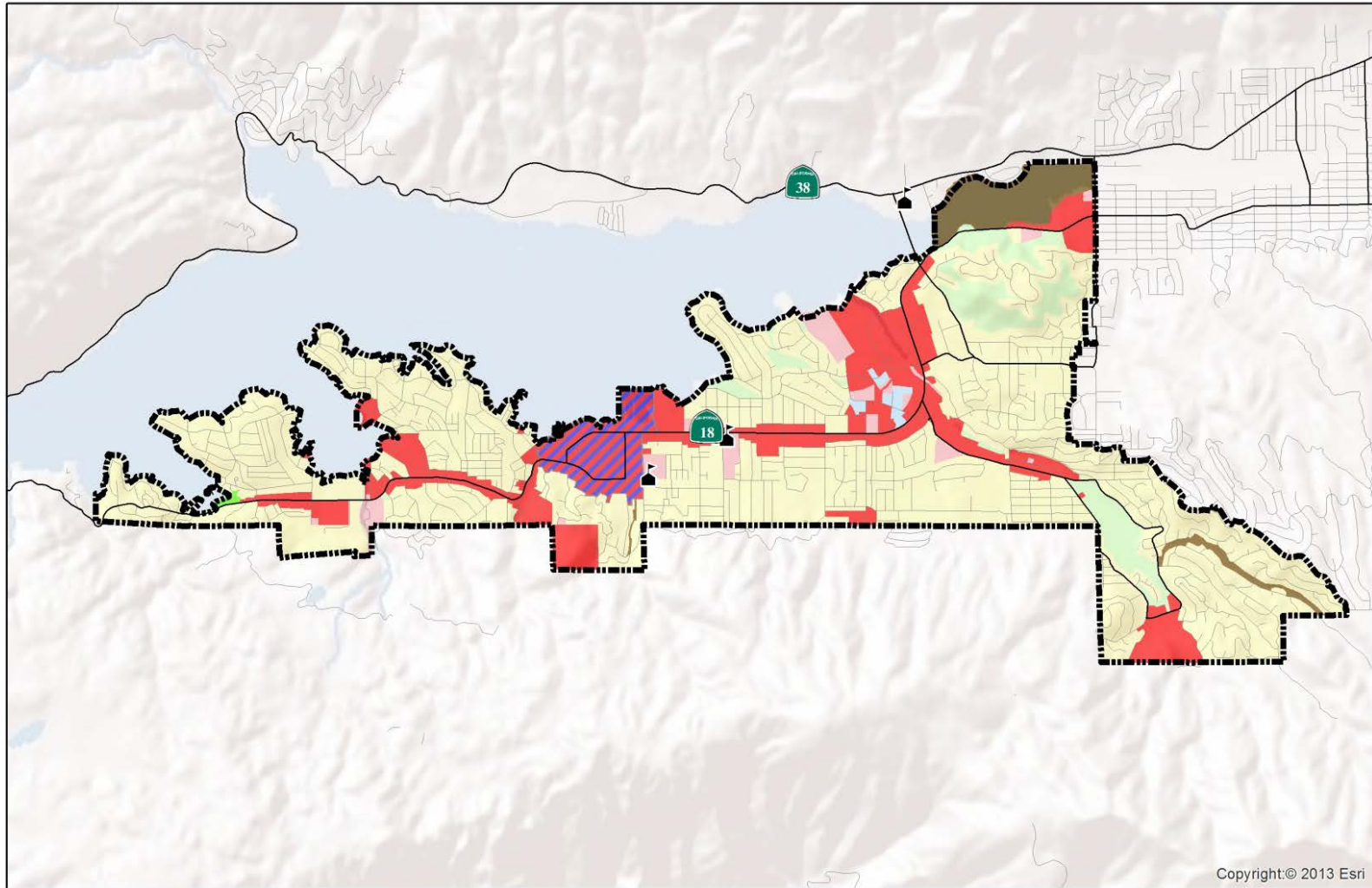

Figure 5.7

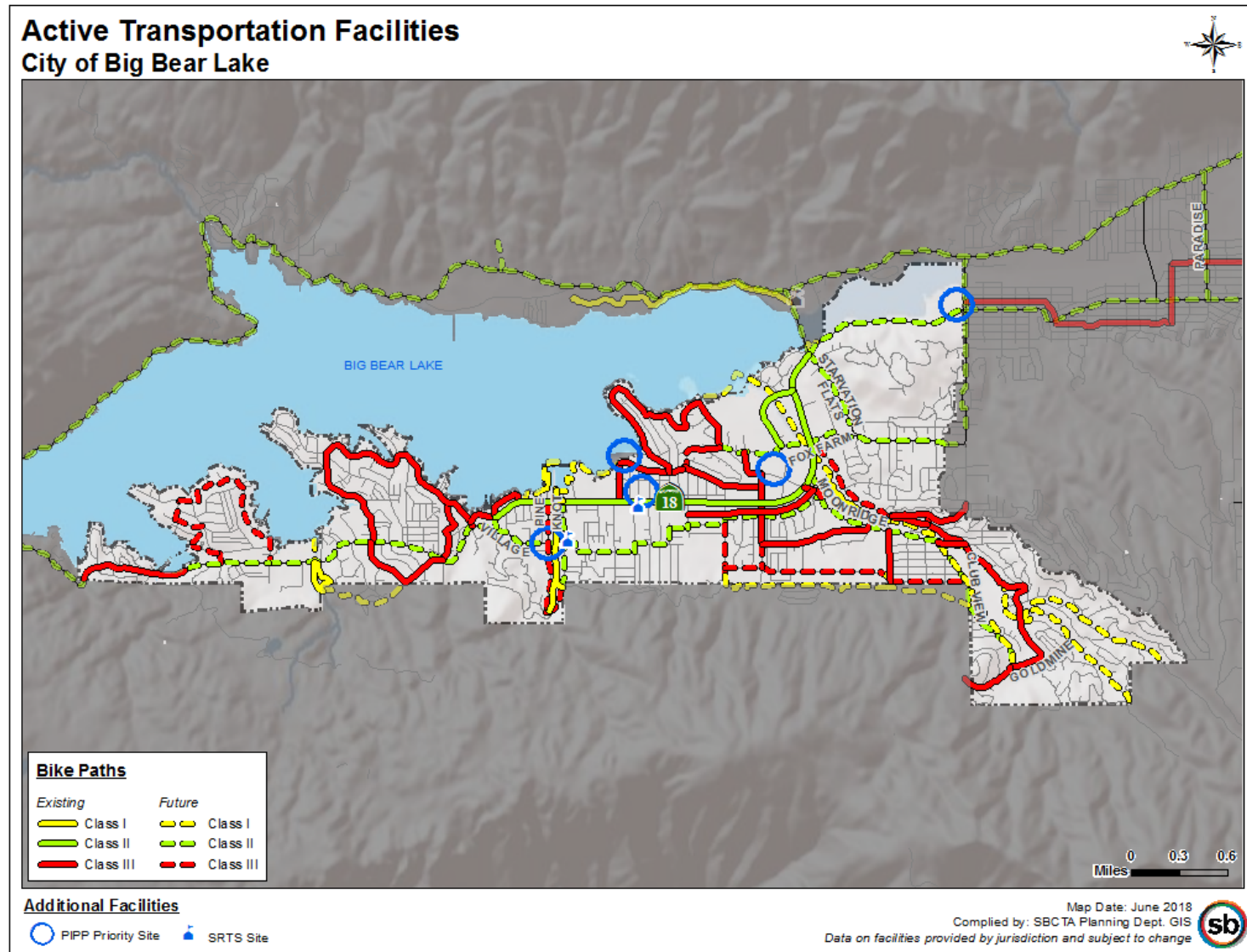

Figure 5.8



**Existing Conditions:**

Table 5.16

Big Bear Lake Existing Conditions

Street/Path	From	To	Class	Length (mi.)	Cost Estimate
Bounder Bay	w/o Talbot Dr.	w/o Skylight Trail	III	0.67	\$10,000
Brownie Ln.	Wren Dr.	Moonridge Rd.	III	0.58	\$10,000
Club View Dr.	Goldmine Dr.	USFS 2N10	III	0.31	\$21,000
Cougar Rd.	Sonoma Dr.	McAllister Rd.	III	0.46	\$17,000
Douglas St.	Sonoma Dr.	Cougar Rd.	III	0.06	\$900
Eagle Point Loop	Park Ave.	Eagle Dr.	III	1.74	\$26,200
East Moonridge Lp.	Douglas St.	Club View Dr.	III	1.47	\$22,050
Elm St.	Moonridge Rd.	Willow Ave.	III	0.31	\$22,000
Evergreen Dr.	Summit Blvd.	Moonridge Rd.	III	0.70	\$10,500
Garstin Rd.	Swan Dr./Fox Farm Rd.	Summit Blvd.	III	0.21	\$3,150
Happy Hill Trail	Lakefront	City Limit	I	0.21	\$1,140,000
Knickerbocker Cr. Tr.	Lakefront	Knickerbocker Rd.	I	0.85	\$1,602,000
Knight Ave.	Big Bear Blvd.	Park Ave.	III	0.24	\$3,600
Moonridge Rd.	Rathbun Dr.	Sonoma Dr.	III	0.17	\$2,650
Moonridge Rd.	SR-18/Big Bear Blvd.	Moonridge Way	III	0.10	\$7,000
North Lakeview Lp.	SR-18	Big Bear Blvd.	III	1.94	\$29,200
North Summit Blvd.	Garstin Rd.	Evergreen Dr.	III	0.43	\$6,600
Paine Rd./Simonds Dr.	Spruce Rd.	SR-18/Big Bear Blvd.	III	0.27	\$4,150
Park Ave.	Park Ave./Wren Dr.	Eureka Dr.	III	0.51	\$7,700
Park Ave./Wren Dr.	Knight Ave.	Park Ave.	III	0.40	\$6,150
Rathbun Trail	Simmons Trout Pond	Elm St.	I	0.50	\$7,343,000
Sandalwood Dr.	Fox Farm Rd.	SR-18	II	0.49	\$48,000
Sonoma Dr.	Catalina Rd.	Douglas St.	III	0.25	\$17,000
South Lakeview Lp.	SR-18	Talmage Rd.	III	0.64	\$9,650
Spruce Rd.	Lakeview Dr.	Paine Rd.	III	0.18	\$2,700
SR-18/Big Bear Blvd	Standfield Cutoff	Paine Ct.	II <sup>A</sup>	2.85	\$143,000
Swan Dr.	Marina Point Dr.	Wren Dr.	III	0.21	\$15,000
Talmadge Rd.	Mill Creek/Big Bear Blvd.	Lakeview Dr.	III	0.48	\$7,200
			<b>Total</b>	<b>17.23</b>	<b>\$10,537,400</b>

TABLE Notes – <sup>A</sup>: Section built by Caltrans with no cost share as reported by jurisdiction

*Growth/Past investment in system*

Since the San Bernardino County Non-Motorized Transportation Plan was first prepared in 2001, the City of Big Bear Lake has constructed 17.23 miles of Class I, Class II, and Class III bikeways at a rate of 1.01 miles per year.



*Past Investment in Non-Motorized Infrastructure*

The City of Big Bear Lake has made an investment in its non-motorized transportation infrastructure. The improvements included in Table 5.16 above reflect an investment of \$10,537,400 based on planning level estimates.

**Proposed Improvements**

The City of Big Bear Lake adopted “Big Bear Valley Pedestrian, Bicycle and Equestrian Master Plan” in 2013. The proposed improvements project list on Table 5.17 reflects the adopted plan routes from the master plan.

Table 5.17

Big Bear Lake Proposed Improvements

Street/Path	From	To	Class	Length (mi.)	Cost Estimate
Aspen Glen Path	Unincorporated Side of City Limit	Edgemoor Rd.	I	0.58	\$590,000
Baldwin Lake Rd.	Minnow Ln.	SR-18/North Shore Dr.	II	2.40	\$120,000
Baldwin Ln.	SR-38	Vista Ave.	III	0.90	\$13,500
Blue Jay Rd.	SR-18/Big Bear Blvd.	Willow Landing Rd.	III	0.06	\$4,000
Brownie Ln.	Thrush Dr.	Moonridge Rd.	II	2.50	\$407,000
Cameron Dr.	Pine Knot Ave.	Knickerbocker Rd.	III	0.05	\$3,000
Catalina Rd.	SR-18/Big Bear Blvd.	Sonoma Dr.	III	0.66	\$46,000
Catbird Ln.	North Bay Rd.	Willow Landing Rd.	III	0.12	\$8,000
Cienega Rd.	Waterview Dr.	SR-18/Big Bear Blvd.	III	0.53	\$37,000
Club View Dr.	Moonridge Rd.	Goldmine Dr.	II	0.93	\$91,000
Eureka Dr.	Mc Whinney Ln.	Oak St.	II	0.10	\$67,000
Fox Farm Rd.	Sandalwood Dr.	E City Limit	II	1.04	\$693,000
Fox Farm Rd./Swan Dr.	Marina Point Dr.	Sandalwood Dr.	II	0.41	\$40,000
Happy Hill Trail	Lakefront	City Limit	I	0.41	\$1,140,000
Jeffries Rd.	Oak St.	Pennsylvania Ave.	II	0.05	\$36,000
Knickerbocker Rd.	SR-18/Big Bear Blvd.	USFS 2N08	II	0.53	\$57,000
Knickerbocker Rd.	Cameron Dr.	USFS 2N08	III	0.16	\$11,000
Maple Ln.	SR-38	Barton Ln.	III	1.31	\$65,500
Mc Whinney Ln.	Eureka Dr.	Thrush Dr.	II	2.50	\$231,000
Moonridge Rd.	Moonridge Way	Club View Dr.	II	0.83	\$81,000
Moonridge Way	SR-18/Big Bear Blvd.	Moonridge Rd.	II	0.12	\$12,000
North Bay Rd.	Woodland Way	Catbird Ln.	III	0.18	\$12,000
Oak St.	Eureka Dr.	Jeffries Rd.	II	0.21	\$140,000
Old Say Rd.	Shay Rd.	Minnow Ln.	II	1.34	\$67,000
Paradise Way	SR-38	SR-18	II	0.79	\$39,500
Pennsylvania Ave.	Jeffries Rd.	Village Dr.	II	0.48	\$322,000
Pine Knot Ave.	SR-18/Big Bear Blvd.	Cameron Dr.	III	0.68	\$47,000
Rathbun Trail	Moonridge Rd.	Goldmine Dr.	I	0.92	\$1,748,000
Rathbun Trail	Moonridge Rd.	USFS	I	1.08	\$2,066,000

Street/Path	From	To	Class	Length (mi.)	Cost Estimate
Rathbun Trail	Shoreline	USFS	I	3.37	\$7,343,000
Shay Rd.	SR-38/Greenway Dr.	Old Shay Rd.	II	0.75	\$37,500
Shoreline Trail	Badger Ln.	Knight Ave.	I	1.40	\$2,661,000
Snow Summit Trail	Thrush Ct.	Club View Dr.	I	1.72	\$1,730,000
SR-18/Big Bear Blvd.	Division Dr.	Shay Rd.	II	2.61	\$130,500
SR-18/Big Bear Blvd.	Cienga Rd.	Castle Rock Trail	II	1.09	\$54,500
SR-18/Big Bear Blvd.	Edgemoor Rd.	Paine Ct.	II	0.99	\$49,500
SR-18/Big Bear Blvd.	Edgemoor Rd.	Cienga Rd.	II <sup>A</sup>	0.69	\$85,500
SR-18/Big Bear Blvd.	SR-38	Castle Rock Trail	II	1.33	\$66,500
SR-18/Big Bear Blvd.	Standfield Cutoff	Division Dr.	II <sup>A</sup>	1.06	\$85,500
SR-18/North Shore Dr.	SR-18/Greenway Dr.	Baldwin Lake Rd.	II	3.94	\$197,000
Switzerland Dr.	Thrush Dr.	Elm Ct.	III	1.03	\$71,000
Thrush Dr.	Brownie Ln.	Mc Whinney Ln.	II	0.06	\$37,000
Thrush Dr.	Mc Whinney Ln.	Thrush Ct.	III	0.36	\$25,000
Village Dr.	Pennsylvania Ave.	Paine Rd.	II	0.45	\$297,000
Waterview Dr.	Woodland Way	Cienega Rd.	III	0.48	\$35,000
Willow Ave.	Elm St.	Club View Dr.	III	0.46	\$32,000
Willow Landing Rd.	Catbird Ln.	Blue Jay Rd.	III	0.19	\$13,000
Woodland Way	North Bay Rd.	Waterview Dr.	III	0.12	\$9,000
Wren Dr.	Mc Whinney Ln.	Mc Whinney Ln.	II	0.02	\$17,000
Wren Dr.	Swan Dr.	Park Ave.	III	0.09	\$6,000
			<b>Total</b>	<b>54.7</b>	<b>\$22,063,050</b>

TABLE NOTES – <sup>A</sup>: Paths share same cost as they are expected to be completed under the same grant already procured by jurisdiction

Table 5.18

Priority Improvements

Street/Path	From	To	Class	Length (mi.)	Cost Estimate
SR-18/Big Bear Blvd.	Cienga Rd.	Castle Rock Trail	II	1.09	\$54,500
SR-18/Big Bear Blvd.	Edgemoor Rd.	Cienga Rd.	II	0.69	\$34,500
SR-18/Big Bear Blvd.	Standfield Cutoff	Division Dr.	II	1.06	\$53,000
Stanfield March Trail	SR-18/Big Bear Blvd	SR-18/North Shore Dr.	I	0.19	\$362,000
Rathbun Trail	Elm St.	Sonoma Dr.	I	0.50	\$500,000
			<b>Total</b>	<b>3.53</b>	<b>\$1,004,000</b>

## Pedestrian Facilities

The City has also identified opportunities to enhance pedestrian facilities. These are described in the 2017 *SBCTA Safe Routes to School Plan (SRTS)* and in the 2017 *SBCTA Points of Interest Pedestrian Plan (PIPP)*. The *SRTS* focuses on improving access to neighborhood schools listed in Table 5.19, while the *PIPP* focuses on improving access to other community assets listed in Table 5.20. Specific improvement recommendations per project are detailed in the *SRTS Plan Phase II – Volume 2* for items in Table 5.19 and the *PIPP* for items in Table 5.20.

Table 5.19  
SRTS Opportunities

Project	Potential Connection to Bikeways, by Status and Class, within ¼ Mile of Project	Number of Improvements Identified	Cost Estimate
Big Bear E.S.	Existing Class I, II & Planned Class II, III	11	\$140,621
Big Bear M.S.	Existing Class II, III & Planned Class II	11	\$212,246
<b>Total</b>		<b>22</b>	<b>\$352,867</b>

Table 5.20  
PIPP Opportunities

Project	Potential Connection to Bikeways, by Status and Class, within ¼ Mile of Project	Proposed Project Ranking
Meadows Park	Existing Class III & Planned Class I	1
Big Bear Convention Center	Planned Class II	2
Big Bear 4 Season Lodge	Existing Class II, III & Planned Class I	3
Brownie Lane Retail Corridor & Library	Existing Class II, III & Planned Class I, II	4
Big Bear Lake City Hall	Existing Class I & Planned Class I, II	NR <sup>A</sup>
Big Bear Lake Village	Existing Class I, II & Planned Class II, III	NR <sup>A</sup>
Big Bear Middle School	Existing Class II, III & Planned Class II	NR <sup>A</sup>
Bear Mountain Resort/Zoo	Existing Class III & Planned Class I, II	NR <sup>A</sup>

TABLE NOTES – <sup>A</sup>: NR = “Not Ranked”, listed as potential project locations and not included in above map.

**Municipal Code**

The municipal code for the City of Big Bear Lake does not currently include the mandatory requirement for the inclusion of non-motorized serving infrastructure as part of the site design process.

**End of Trip Facilities**

The City of Big Bear Lake has bike racks dispersed throughout the City, typically at retail centers, schools and multi-unit housing complexes.

**Multimodal Connectivity**

The City of Big Bear Lake has the following multimodal facilities that interface with the non-motorized transportation system.

Table 5.21

Multimodal Connectivity

Facility	Facility Type	Facility Location
City-wide Bus Stops	Bus Stops	Throughout City

**Collisions Involving Bicyclists**

Table 5.22

Data for Collisions Involving Bicyclists

Parameter	Collision Rate
Total # of Bicycle Collisions from 2012-2016	8
Total # of Bicycle Fatalities from 2012-2016	0
Total # of Bicycle Injuries from 2012-2016	8
Average # of Bicycle Collisions Per Year	1.6
Average Bicycle Collision Rate per 1000/year <sup>1</sup>	0.29

Notes:

1. Rate is calculated using SWITRS collision data and population figures by the California Department of Finance

### **Safety and Education Programs**

The City of Big Bear Lake does not currently have any ongoing bicycle safety or education programs. However, all of the City's fleet, including partnering agencies Big Bear Disposal and Mountain Transit have installed "Bicycle Safety" decals as part of a safety awareness campaign advising motorists to keep a 3 foot distance away from bicyclists.

## City of Chino

### Population

79,873

### City Overview

The City of Chino is comprised of approximately 29.5 square miles of area and is bounded by the SR-71 to the West, the City of Montclair to the north, the City of Chino Hills to the east and the County of Riverside to the south. The City is located 35 miles from downtown Los Angeles, 30 miles from downtown San Bernardino and 30 miles to the City of Irvine. The City of Chino is at the center of the Los Angeles Basin.

Chino began as an agricultural community around a railroad depot in 1887. The City maintained its agricultural focus well into the 1940s, expanding its focus to include dairy production. In the 1980s, the City shifted toward industrial, warehouse, and distribution land uses with those land uses clustered around the SR-71 and SR-60 freeways. The dairy farms in the south area of the City are in the process of transition into residential and mixed use developments.

### Land Use

The map in Figure 5.9 shows the current and future land use patterns in the City of Chino. Industrial and warehouse uses are most common in the southern portions of the City and take advantage of the City's location along major trucking routes and near rail lines and the Ontario Airport. The City's primary commercial areas are located along major transportation routes, including SR-71, SR-83 (Euclid Avenue), Grand/Edison Avenues, Central Avenue, Riverside Drive, and Philadelphia Street. As the City has developed these additional land uses, it has significantly reduced the land area devoted to agricultural production, although there are still some scattered agricultural uses. Future growth in the City will primarily occur around major transportation corridors with healthy transportation options, a small-town feel, and the ability to provide for residents' daily needs.

### Existing Conditions:

Chino's non-motorized bicycle network is one of the more robust in San Bernardino County. The City contains one traditional Class I bikeway on Edison Ave. adjacent to Ruben Ayala Park and it includes several segments of Class I style cycle tracks along portions of several streets in the Preserve and College Park sections of the City. In total, the City of Chino has constructed 3.02 miles of Class I, 21.87 miles of Class II and 2.6 miles of Class III facilities.



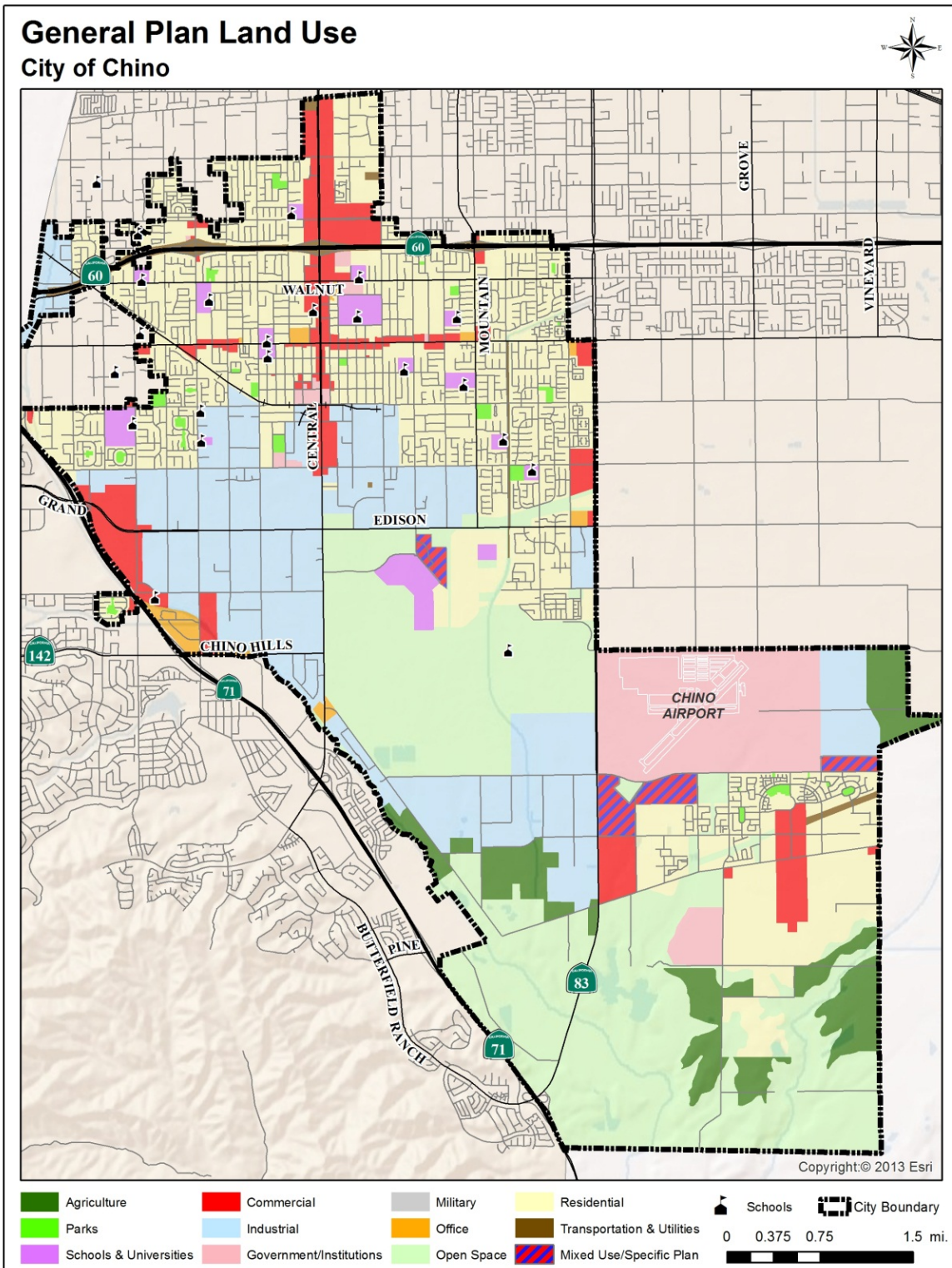

Figure 5.9

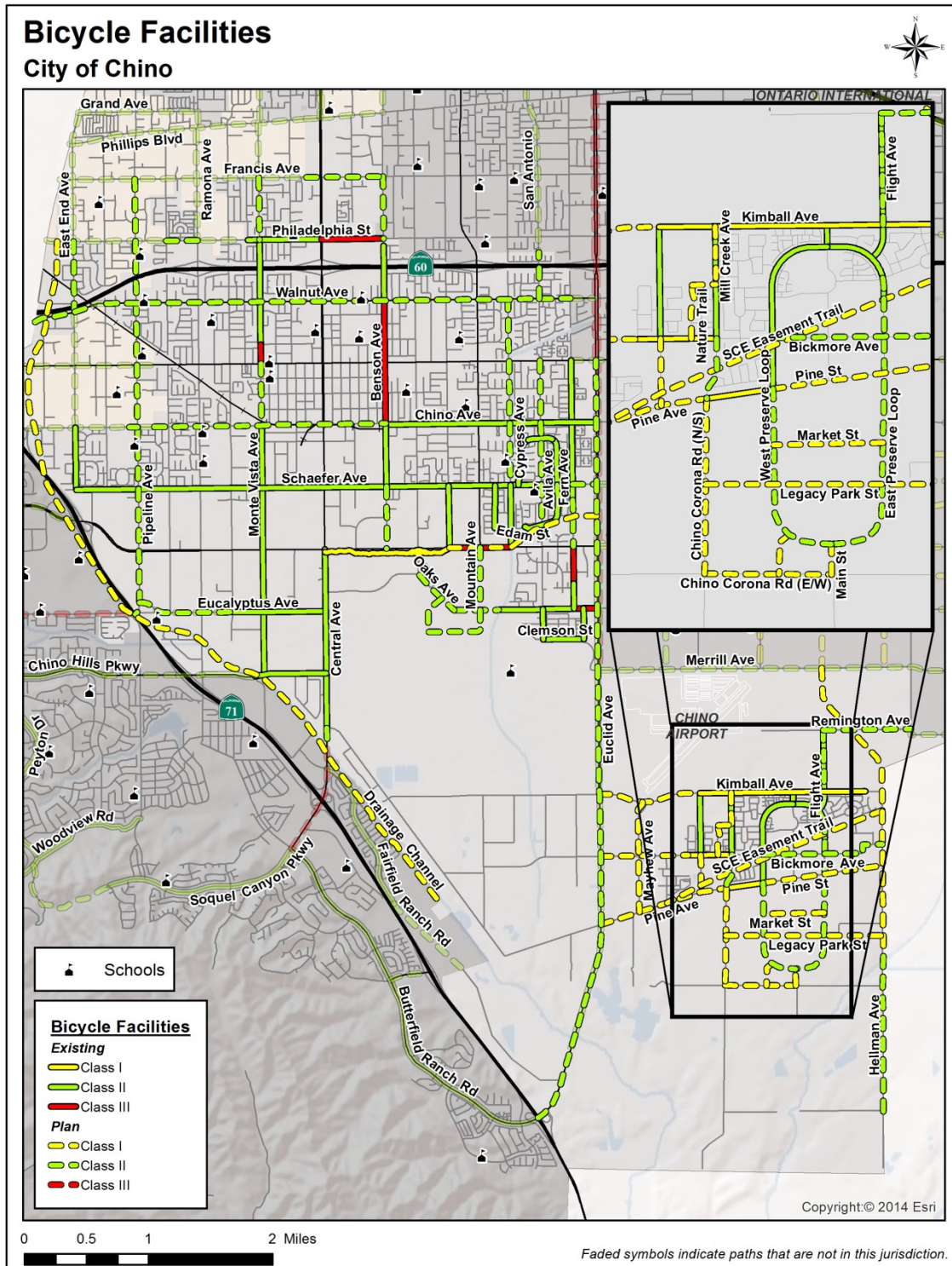

Figure 5.10

Table 5.23

Chino Existing Conditions

Street/Path	From	To	Class	Length (mi.)	Cost Estimate
Alvarado St.	S North Ave.	Treadwell Ave.	II	0.19	\$9,500
Amsterdam Ave.	Schaefer Ave.	Dalton St.	II	0.34	\$17,000
Avila Ave.	S North Ave.	Schaefer Ave.	II	0.37	\$18,500
Avila Ave.	Schaefer Ave.	Edam St.	II	0.32	\$16,000
Benson Ave.	Walnut Ave.	Chino Ave.	III	0.99	\$14,850
Benson Ave.	Chino Ave.	Shaefer Ave.	II	0.50	\$25,000
Benson Ave.	Monticello St.	Walnut Ave.	II	0.44	\$22,000
Bickmore Ave.	Moonflower Ave.	Mill Creek Ave.	I	0.35	\$350,000
Central Ave.	Edison Ave.	El Prado Rd.	II	1.44	\$72,000
Chino Ave.	Benson Ave.	Euclid	II	1.70	\$85,000
Chino Hills Pkwy	Monte Vista Ave.	Central Ave.	II	0.57	\$28,500
Clemson St.	Purdue Ave.	San Antonio Ave.	II	0.32	\$16,000
Cypress Ave.	Schaefer Ave.	Edison Ave.	II	0.50	\$25,000
East End Ave.	Chino Ave.	Schaefer Ave.	II	0.50	\$25,000
East Preserve Loop	Main St.	s/o Forest Park St.	II	0.45	\$22,500
Edam St.	Avila Ave.	Rancho Del Chino Ave.	II	0.22	\$11,000
Edison Ave.	Central Ave.	Magnolia Ave.	I	1.00	\$1,000,000
Edison Ave.	Magnolia Ave.	Cypress Ave.	III	0.49	\$7,350
Eucalyptus Ave.	Central Ave.	Yorba Ave.	II	0.74	\$37,000
Eucalyptus Ave.	Euclid Ave.	Fern Ave.	III	0.18	\$2,700
Eucalyptus Ave.	Fern Ave.	Cypress St.	II	0.61	\$30,500
Fern Ave.	Riverside Dr.	Schaefer Ave.	II	1.00	\$50,000
Fern Ave.	Schaefer Ave.	Hickory St.	II	0.12	\$6,000
Fern Ave.	Edison Ave.	n/o Persimmon St.	III	0.29	\$4,350
Fern Ave.	n/o Persimmon St.	Eucalyptus Ave.	II	0.20	\$10,000
Flight Ave.	East Preserve Loop	Kimball Ave.	II	0.66	\$33,000
Kimball Ave.	Rincon Meadow Rd.	w/o Hellman Ave.	I	1.37	\$1,370,000
Magnolia Ave.	Schaefer Ave.	Edison Ave.	II	0.50	\$25,000
Main St.	Kimball Ave.	East Preserve Loop	II	0.09	\$4,500
Mill Creek Ave.	Kimball Ave.	Bickmore Ave.	II	0.50	\$25,000
Monte Vista Ave.	Chino Ave.	Chino Hills Pkwy	II	2.00	\$100,000
Monte Vista Ave.	Philadelphia St.	Lincoln Ave.	II	0.84	\$42,000
Monte Vista Ave.	Lincoln Ave.	Riverside Dr.	III	0.15	\$2,250
Philadelphia St.	Carlisle Ave.	Central Ave.	II	0.59	\$29,500
Philadelphia St.	Central Ave.	Benson Ave.	III	0.50	\$7,500
Pine St.	Mill Creek Ave.	West Preserve Loop	I	0.30	\$300,000
Purdue Ave.	Eucalyptus Ave.	Clemson St.	II	0.24	\$12,000
Rancho Del Chino Ave.	Treadwell Ave.	Schaefer Ave.	II	0.38	\$19,000
Rincon Meadows Ave.	Kimball Ave.	Bickmore Ave.	II	0.50	\$25,000
San Antonio Ave.	Clemson St.	Eucalyptus Ave.	II	0.24	\$12,000
Schaefer Ave.	East End Ave.	Fern Ave.	II	4.00	\$200,000
West Preserve Loop	Pine Ave.	Main St.	II	0.80	\$40,000
			<b>Total</b>	<b>27.49</b>	<b>\$4,152,500</b>



In addition, the City has also striped 21.87 miles of Class II bike lanes, mostly on major transportation corridors throughout the City. Large stretches of Class II facilities currently exist along sections of Benson Ave., Central Ave., Chino Ave., Monte Vista Ave., and Schaefer Ave. The bike lanes establish a backbone grid network, connecting commercial, residential, educational and recreational amenities throughout the city. Finally, 2.6 miles of designated Class III bike routes also exist in small sections throughout the City. The Class III facilities tend to be in areas with limited right-of-way on the existing roadways or where gaps in the Class II network exist.

*Past Investment in Non-Motorized Infrastructure*

The improvements included in Table 5.23 above constitute a significant investment into the non-motorized transportation infrastructure of Chino. Based on planning level estimates, the value of the improvements implemented throughout the City is \$4,152,500.

**Proposed Improvements**

Future improvements to the non-motorized network for the City of Chino will continue along the major transportation corridors throughout the City and connecting new residential neighborhoods to the non-motorized system. Most of the future improvements in the City are Class II facilities, but there are several regional Class I facilities proposed as well. A new north/south Class I facilities is proposed along the western drainage channel, which generally parallels the SR-71 freeway along the western boundary of the City. The City of Chino does not currently propose to add additional Class III facilities at this time. A table of future improvements is included in Table 5.24 below.

The City of Chino has not identified any priority improvements as part of this plan.

Table 5.24

Chino Proposed Improvements

Street/Path	From	To	Class	Length (mi.)	Cost Estimate
Benson Ave.	Francis Ave.	Philadelphia St.	II	0.50	\$25,000
Benson Ave.	Schaefer Ave.	Edison Ave.	II	0.50	\$25,000
Bickmore Ave.	Euclid Ave.	Moonflower Ave.	I	0.70	\$700,000
Bickmore Ave.	W Preserve Loop	Hellman Ave.	II	1.03	\$51,500
Central Ave.	El Prado Rd.	Drainage Channel	II	0.14	\$7,000
Chino Ave.	Preciado Ave.	Benson Ave.	II	1.86	\$93,000
Chino Ave.	Unincorporated Boundary w/ of Pipeline	Pipeline	II	0.06	\$3,000
Chino Corona Rd. (E/W)	Chino Corona Rd. (N/S)	Main St.	I	0.56	\$560,000
Chino Corona Rd. (N/S)	Pine Ave.	Chino Corona Rd. (E/W)	I	0.78	\$780,000
Cypress Ave.	Walnut Ave.	Schaefer Ave.	II	1.49	\$74,500

NMTP - Revised June 2018 - City of Chino

Drainage Channel	Philadelphia St.	Flower St.	I	6.70	\$6,700,000
East End Ave.	Philadelphia St.	Chino Ave.	II	0.54	\$27,000
East Preserve Loop	Main St. (south side of loop)	Forest Park St.	II	1.34	\$67,000
Edison Ave.	Cypress Ave. (along SCE Easement)	Euclid Ave.	I	0.75	\$750,000
Edison Ave.	Magnolia Ave.	Cypress Ave.	I	0.49	\$490,000
Eucalyptus Ave.	Cypress Channel	Oaks Ave.	II	0.35	\$17,500
Eucalyptus Ave.	Pipeline Ave.	Yorba Ave.	II	0.77	\$38,500
Euclid Ave.	Riverside Dr.	SR-71	II	6.08	\$304,000
Fern Ave.	Hickory St.	Edison Ave.	II	0.37	\$18,500
Flight Ave.	Kimball Ave.	Remington Ave.	II	0.49	\$24,500
Francis Ave.	Benson Ave.	West City Limit	II	0.61	\$30,500
Future Street (south end of loop)	West Preserve Loop	Chino Corona Rd. (E/W)	I	0.19	\$190,000
Future Street south of Eucalyptus Ave.	Eucalyptus Ave.	Mountain Ave.	II	0.75	\$37,500
Hellman Ave.	Hereford Dr.	McCarty Rd.	II	1.24	\$62,000
Hellman Ave.	Merrill Ave.	Hereford Dr.	I	2.50	\$2,500,000
Kimball Ave.	Euclid Ave.	Rincon Meadows Ave.	I	0.82	\$820,000
Legacy Park St.	Chino Corona Rd. (N/S)	Hellman Ave.	I	1.26	\$1,260,000
Main St.	E/W Preserve Loop	Chino Corona Rd. (E/W)	I	0.13	\$130,000
Market St.	West Preserve Loop	East Preserve Loop	I	0.48	\$480,000
Mayhew Ave.	Kimball Ave.	Pine Ave.	I	0.89	\$890,000
Mill Creek Ave.	Bickmore Ave.	Pine Ave.	II	0.28	\$14,000
Mill Creek Ave.	Kimball Ave.	Spring Hill St.	I	0.25	\$250,000
Monte Vista Ave.	Philadelphia St.	Francis Ave.	II	0.50	\$25,000
Monte Vista Ave.	Riverside Dr.	Chino Ave.	II	0.50	\$25,000
Mountain Ave.	Edison Ave.	Eucalyptus Ave.	II	0.50	\$25,000
Mountain Ave.	Eucalyptus Ave.	(Future Street to west)	II	0.15	\$7,500
Nature Trail	Spring Hill St.	Bickmore Ave.	I	0.24	\$240,000
Oaks Ave.	Eucalyptus Ave.	Edison Ave.	II	0.64	\$32,000
Philadelphia St.	Drainage Channel	W City Limit	II	0.29	\$14,500
Pine Ave.	Euclid Ave.	Mill Creek Ave.	I	1.05	\$1,050,000
Pine St.	West Preserve Loop	Hellman Ave.	I	0.97	\$970,000
Pipeline Ave.	Francis Ave.	Drainage Channel	II	3.51	\$175,500
Remington Ave.	Flight Ave.	Carpenter St.	II	0.70	\$35,000
Ricon Meadows Ave.	Bickmore Ave.	Pine Ave.	I	0.29	\$290,000
San Antonio Ave.	Riverside Dr.	Edam St.	II	1.32	\$66,000
San Antonio Ave.	Northern City Limits	Walnut Ave.	II	.37	\$18,500
SCE Easement Trail	Pine Ave.	Hellman Ave.	I	1.88	\$1,880,000
Schaefer Ave.	Fern Ave.	Euclid Ave.	II	0.19	\$9,500
Spring Hill St.	Mill Creek Ave.	Nature Trail	I	0.10	\$100,000
Walnut Ave.	West City Limit	Fern Ave.	II	4.23	\$211,500
West Preserve Loop	Pine Ave.	Main St. (south side of loop)	II	0.86	\$43,000
			<b>Total</b>	<b>53.19</b>	<b>\$22,638,000</b>

Table 5.25

Priority Improvements

Street/Path	From	To	Class	Length (mi.)	Cost Estimate
n/a	n/a	n/a	n/a	n/a	n/a
			<b>Total</b>	<b>n/a</b>	<b>n/a</b>

**General Plan**

The City of Chino General Plan includes the following provisions governing the provision of non-motorized infrastructure:

*Goal TRA-10 Foster bicycling as a convenient, healthy and environmentally-friendly travel choice in Chino.*

*Objective TRA-10.1 Increase the use of bicycle travel within Chino.*

Policies

P1. Libraries, schools, community centers, and other important community facilities in Chino shall have bicycle parking, including racks and lockers as appropriate.

P2. The City shall require new development to provide off-street bicycle parking per zoning standards, and shall review those standards periodically to ensure that adequate bicycle parking is being provided.

P3. The City shall encourage employers of 100 or more full-time equivalent employees to provide showers and lockers for bicycle commuters.

P4. Incorporate bicycle paths/trails/facilities outside the street right-of-way in all new development, consistent with the Bicycle Master Plan.

*Objective TRA-10.2 Increase the connectivity, safety and convenience of the bicycle network.*

Policies

P1. The City shall enhance and improve bicycle connections between neighborhoods, and between neighborhoods and significant destinations such as parks, schools, transit stops and transit centers, shopping centers, and employment centers.



P2. Where existing street width or traffic volumes do not support creation or maintenance of striped bicycle lanes, the City shall indicate to both drivers and bicyclists that bicycle use is permitted and should be expected through “sharrows” pavement markings, “share the road” signage, or other mechanisms.

P3. The City shall evaluate proposed new development and redevelopment projects to ensure that they include consideration of connections to the Chino bicycle circulation system and provide bicycle parking and other facilities for bicyclists, as appropriate to the development type.

Actions

A1. Prepare a Bicycle Master Plan for the City of Chino that establishes where and how the City’s bicycle network will be expanded, including standards to guide review of roadway enhancements or other changes to the roadway system. This plan should be consistent with requirements for allocation of State Bicycle Transportation Account Funds and federal funding for bicycle improvements that cannot be allocated without an approved Bicycle Master Plan. The plan should also include criteria for funding prioritization of improvements.

A2. Develop maps or signage indicating local and regional bicycle routes, including distances to key destinations, such as parks and schools.

**End of Trip Facilities**

The City of Chino has bike racks dispersed throughout the City, typically at retail centers and multi-unit housing complexes.

**Multimodal Connectivity**

The City of Chino has the following multimodal facilities that interface with the non-motorized transportation system.

Table 5.26

Multimodal Connectivity

Facility	Facility Type	Facility Location
Chino Ave PNR Lot	Ride Share Lot	3321 Chino Ave
Chino Transit Center	Multi-Modal Facility	6 <sup>th</sup> St and Chino Ave
City-wide Bus Stops	Bus Stops	Throughout City

## Collisions Involving Bicyclists

Table 5.27

### Data for Collisions Involving Bicyclists

Parameter	Collision Rate
Total # of Bicycle Collisions from 2007-2011	119
Total # of Bicycle Fatalities from 2007-2011	2
Total # of Bicycle Injuries from 2007-2011	104
Average # of Bicycle Collisions Per Year	23.8
Average Bicycle Collision Rate per 1000/year <sup>1</sup>	0.31

Notes:

1. Rate is calculated using SWITRS collision data and population figures by the California Department of Finance

## Safety and Education Programs

The City of Chino does not currently participate in any bicycle safety or education programs.

## City of Chino Hills

### **Population**

83,159

### **City Overview**

Incorporated in 1991, the City of Chino Hills is located in the western foothills of San Bernardino County. The City is comprised of 46 square miles with 3,000 acres of publicly owned open space, 40 parks and 39 miles of hiking trails.

The City is also home to the Chino Hills State Park, which provides another 14,102 acres of open space that includes scenic vistas of the San Bernardino Valley and an additional 65 miles of trails that can be used for hiking, biking or horseback riding.

### **Land Use**

The map in Figure 5.93 shows the General Plan land use map for the City of Chino Hills. The City is largely built out and seeing the maturation of its residential, commercial and industrial centers. Most of the City's open space and agricultural lands provide a buffer around its northern, western and southern city boundaries. The City also contains a significant amount of residential land use along the ridges and hillsides that transition into the San Bernardino Valley floor. Commercial and industrial land uses tend to be clustered around State Route 71, which is a major north-south transportation corridor on the eastern edge of the City.

### **Existing Conditions:**

Chino Hill's non-motorized bicycle network has expanded significantly since the last update to the Non-Motorized Transportation Plan. The City's infrastructure now includes a 20.21 miles of Class II and III bike infrastructure, mostly on major transportation corridors throughout the City. The major corridors that now include Class II bike lanes include: Butterfield Ranch Road, Chino Hills Parkway and Peyton Drive. Also, portions of Fairfield Ranch Road, Soquel Canyon Road and Woodview Road contain Class II bike lanes. The bike lanes provide connectivity to commercial, residential, educational and recreational amenities throughout the city.

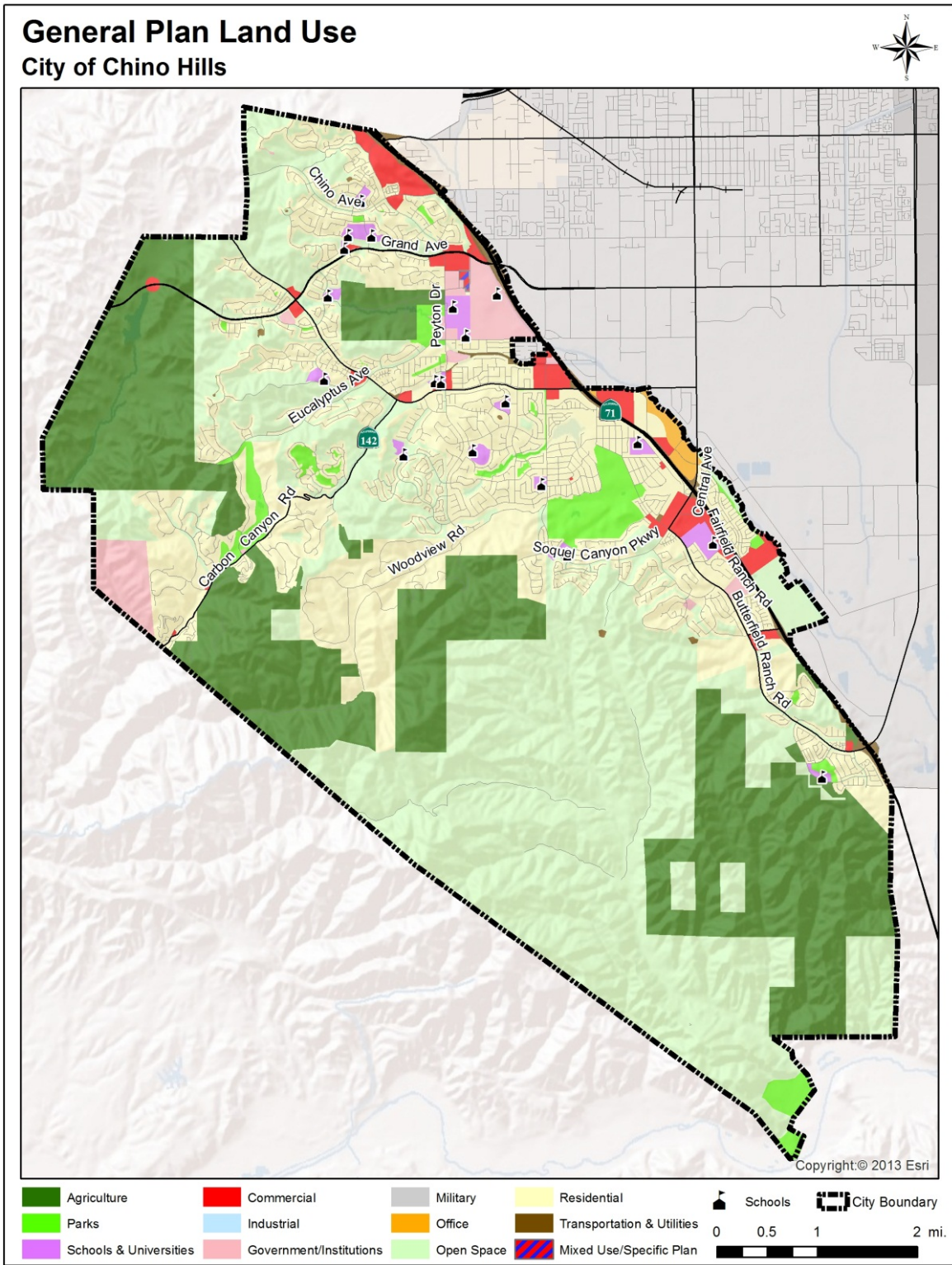
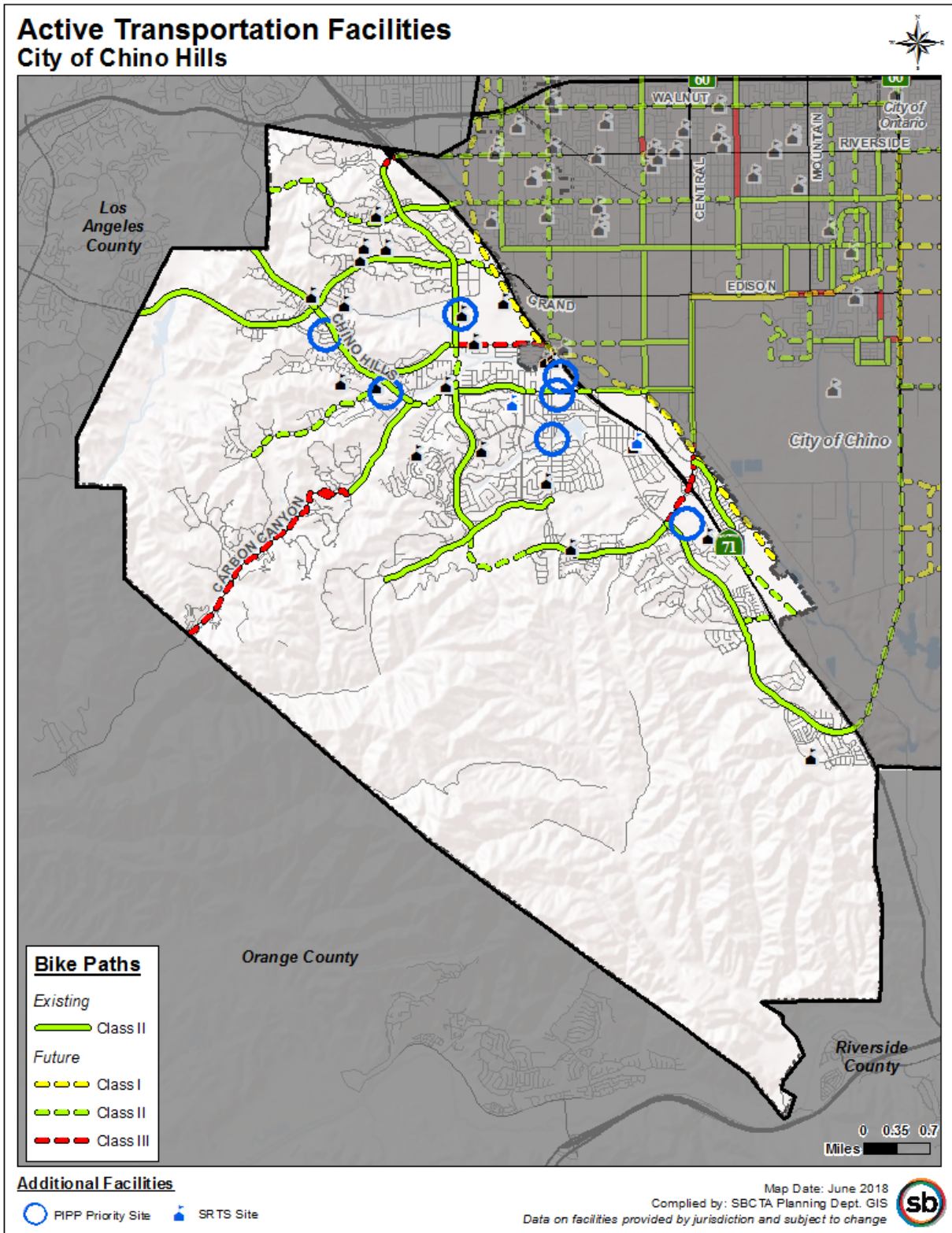

Figure 5.11





C:\Users\christopher\Documents\Projects\BikePlan\_Feb16\start\DataDrivenMaps\ATP\_Portrait.mxd

Figure 5.12

Table 5.28

Chino Hills Existing Conditions

Street/Path	From	To	Class	Length (mi.)	Estimated Cost
Butterfield Ranch Rd.	Soquel Canyon Pkwy.	Shady View Dr.	II	3.07	\$153,500
Carbon Canyon Rd.	Old Carbon Canyon Rd.	Chino Hills Pkwy.	II	1.33	\$66,500
Chino Ave.	Peyton Dr.	SR-71	II	0.51	\$25,500
Chino Hills Pkwy.	Grand Ave.	Carbon Canyon Rd.	II	1.44	\$72,000
Chino Hills Pkwy.	N City Limit	Grand Ave.	II	0.92	\$46,000
Chino Hills Pkwy.	Peyton Dr.	Rolling Ridge Dr.	II	0.72	\$36,000
Chino Hills Pkwy.	Ramona Ave.	Monte Vista Ave.	II	0.43	\$21,500
Eucalyptus Ave.	Chino Hills Pkwy.	Chino Hills Community Park	II	0.78	\$39,000
Fairfield Ranch Rd.	Soquel Canyon Pkwy.	Big League Dreams	II	1.27	\$63,500
Grand Ave.	W City Limit	Peyton Dr.	II	3.76	\$188,000
Peyton Dr.	Rock Springs Dr.	Eucalyptus Ave.	II	2.16	\$108,000
Peyton Dr.	Woodview Rd.	Chino Hills Pkwy.	II	1.61	\$80,500
Soquel Canyon Pkwy.	Butterfield Ranch Rd.	Golden Terrace Ln	II	1.61	\$80,500
Woodview Dr.	Peyton Dr.	Vellano Club Dr.	II	2.04	\$102,000
			<b>Total</b>	<b>21.65</b>	<b>\$1,082,500</b>

*Past Investment in Non-Motorized Infrastructure*

The improvements included in Table 5.28 above constitute a significant investment into the non-motorized transportation infrastructure of Chino Hills. Based on planning level estimates, the value of the improvements implemented throughout the City is \$1,082,500.

**Proposed Improvements**

Future improvements to the non-motorized network for the City of Chino Hills will continue along the major transportation corridors throughout the City. All future improvements focus on further development of additional Class II facilities. A table of future improvements is included in Table 5.29 below.

In conjunction with the widening of Peyton Drive the City intends to construct Class II bike lanes from English Drive to Chino Hills Parkway.

While the state routes within the City Limits of Chino Hills are included as potential future projects, at this time it is unlikely that the City will directly initiate those projects.



Table 5.29

Chino Hills Proposed Improvements

Street/Path	From	To	Class	Length (mi.)	Cost Estimate
Carbon Canyon Rd.	E City Limit	Old Carbon Canyon Rd.	III	2.69	\$40,350
Central Ave.	SR-71	Drainage Channel	III	0.43	\$6,450
Chino Ave.	W. City Limits	Peyton Dr.	II	1.63	\$81,500
Chino Hills Pkwy.	Carbon Canyon Rd.	Peyton Dr.	II	0.52	\$26,000
Chino Hills Pkwy.	Rolling Ridge Dr.	SR-71	II	0.59	\$29,500
Chino Hills Pkwy.	SR-71	Ramona Ave.	II	0.19	\$9,500
Eucalyptus Ave.	Chino Hills Community Park	Peyton Dr.	II	0.09	\$4,500
Eucalyptus Ave.	Peyton Ave.	Pipeline Ave.	III	0.95	\$14,250
Eucalyptus Ave.	Rancho Hills Dr.	Chino Hills Pkwy.	II	1.66	\$83,000
Fairfield Ranch Rd.	Big League of Dreams	Pine Ave.	II	0.77	\$38,500
Grand Ave.	Peyton Dr.	SR-71	II	0.50	\$25,000
Peyton Dr.	Eucalyptus Ave.	Chino Hills Pkwy.	II	0.50	\$25,000
Peyton Dr.	Rock Springs Rd.	SR-71	III	0.20	\$3,000
Pine Ave.	Butterfield Ranch Rd.	SR-71	II	0.32	\$16,300
Soquel Canyon Pkwy.	Butterfield Ranch Rd.	SR-71	III	0.47	\$7,000
Soquel Canyon Pkwy.	Peyton Dr.	Golden Terrace Ln.	II	0.94	\$47,000
			<b>Total</b>	<b>12.45</b>	<b>\$456,850</b>

Table 5.30

Priority Improvements

Street/Path	From	To	Class	Length (mi.)	Cost Estimate
Peyton Dr.	Eucalyptus Ave.	Chino Hills Pkwy.	II	0.50	\$25,000
Eucalyptus Ave.	Chino Hills Community Park	Peyton Dr.	II	0.09	\$4,500
			<b>Total</b>	<b>0.59</b>	<b>\$29,500</b>

**Pedestrian Facilities**

The City has also identified opportunities to enhance pedestrian facilities. These are described in the 2017 SBCTA *Safe Routes to School Plan (SRTS)* and in the 2017 SBCTA *Points of Interest Pedestrian Plan (PIPP)*. The SRTS focuses on improving access to neighborhood schools listed in Table 5.31, while the PIPP focuses on improving access to other community assets listed in Table 5.32. Specific improvement recommendations per project are detailed in the *SRTS Plan Phase II – Volume 2* for items in Table 5.31 and the PIPP for items in Table 5.32.

Table 5.31  
SRTS Opportunities

Project	Potential Connection to Bikeways, by Status and Class, within ¼ Mile of Project	Number of Improvements Identified	Cost Estimate
Chaparral E.S.	None	9	\$1,927,382
Glenmeade E.S.	Existing Class II	7	\$356,643
<b>Total</b>		<b>16</b>	<b>\$2,284,025</b>

Table 5.32  
PIPP Opportunities

Project	Potential Connection to Bikeways, by Status and Class, within ¼ Mile of Project	Proposed Project Ranking
Chino Hills Marketplace	Planned Class I, II	1
Lake Los Serranos Club	None	1
Autumn Hill Park & English Springs Park	Existing Class II	2
Crossroads/Veterans Park	Existing Class II & Planned Class II	3
Ruben S. Ayala High & Gerald F. Litel Elementary	Existing Class II	4
Village Crossing at Chino Hills near Glenmead Park	Planned Class II	5
Butterfield/Meadows Park	Existing Class II	NR <sup>A</sup>
Chino Hills High School	Existing Class II & Planned Class III	NR <sup>A</sup>

TABLE NOTES – <sup>A</sup>: NR = “Not Ranked”, listed as potential project locations and not included in above map.

### Municipal Code

Chino Hills Municipal Code Section 16.34.060 (E) - Number of parking spaces required - provides the following requirements related to bicycle parking spaces:

Bicycle Parking. Parking spaces for bicycles shall be provided as required by Table 65-2. For any use for which bicycle parking is required, a minimum of four bicycle spaces shall be provided.

### End of Trip Facilities

The City of Chino Hills has bike racks dispersed throughout the City, typically at retail centers and multi-unit housing complexes.

### Multimodal Connectivity

The City of Chino Hills has the following multimodal facilities that interface with the non-motorized transportation system.

Table 5.33

#### Multimodal Connectivity

Facility	Facility Type	Facility Location
St. Paul the Apostle Church	Ride Share Lot	14085 Peyton Dr.
City-wide Bus Stops	Bus Stops	Throughout City

### Collisions Involving Bicyclists

Table 5.34

#### Data for Collisions Involving Bicyclists

Parameter	Collision Rate
Total # of Bicycle Collisions from 2012-2016	22
Total # of Bicycle Fatalities from 2012-2016	0
Total # of Bicycle Injuries from 2012-2016	22
Average # of Bicycle Collisions Per Year	4.4
Average Bicycle Collision Rate per 1000/year <sup>1</sup>	0.05

Notes:

1. Rate is calculated using SWITRS collision data and population figures by the California Department of Finance

### Safety and Education Programs

The City of Chino Hills does not participate in safety or education programs specific to non-motorized transportation or the placement of non-motorized transportation facilities.

## City of Colton

### Population

52,956

### City Overview

The City of Colton is one of San Bernardino County's truly historic cities. Incorporated in 1887, the community began growing in 1883 when the Southern Pacific Railroad linked Southern California to the rest of the nation by rail. The City remains strategically located at the crossroads of the Inland Empire. Geographically the City encompasses an area of approximately 18 square miles and is located at the junction of the I-10 and I-215 freeways.

Colton is a small town with a downtown corridor of authentic character as well as historic homes, parks, unique shops and restaurants, alongside the beautifully restored Andrew Carnegie Library Building.

### Land Use

The map in Figure 5.13 shows the land use coverage in the City of Colton's General Plan. Due to the age of the City, most of the City's housing stock is older by comparison to the rest of the Inland Empire, with 37.6% of the City's housing stock built before 1970. The City is also nearing build-out of its residential neighborhoods, and as such, will remain largely suburban in form.

The City's General Plan offers a variety of commercial, retail, mixed use development opportunities. Most of the remaining developable land is located in Agua Mansa, the Pellisier Ranch Area (south Colton) and the Colton Superblock. The overall vision for the Superblock is a transit oriented development which includes, a vibrant, walkable, compact, mixed-use district focused around premium transit along San Bernardino Avenue, Pepper Avenue, and Valley Boulevard with potential transit stations on San Bernardino and Pepper Avenues. A more pedestrian-friendly environment served by multimodal transportation would reduce traffic congestion prevalent in the surrounding areas.

### Existing Conditions:

Colton's non-motorized bicycle network has expanded significantly since the last update to the Non-Motorized Transportation Plan. The City now enjoys two Class I bikeways, for a total of 7.27 miles. The first bikeway is along the Santa Ana River throughout the entire length of the river in the City. The second bikeway is located along the former Pacific Electric right-of-way on Colton Ave.

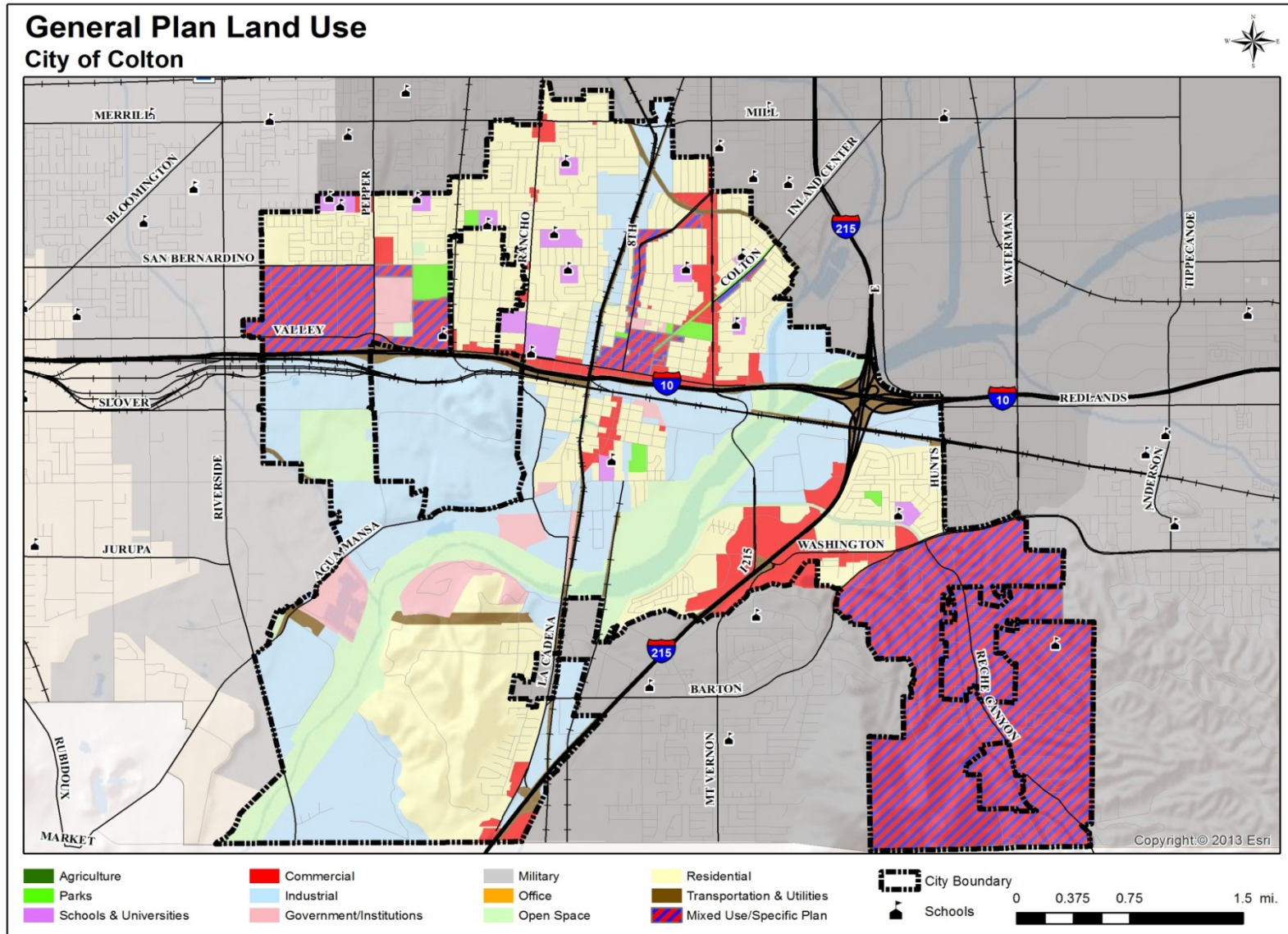

Figure 5.13



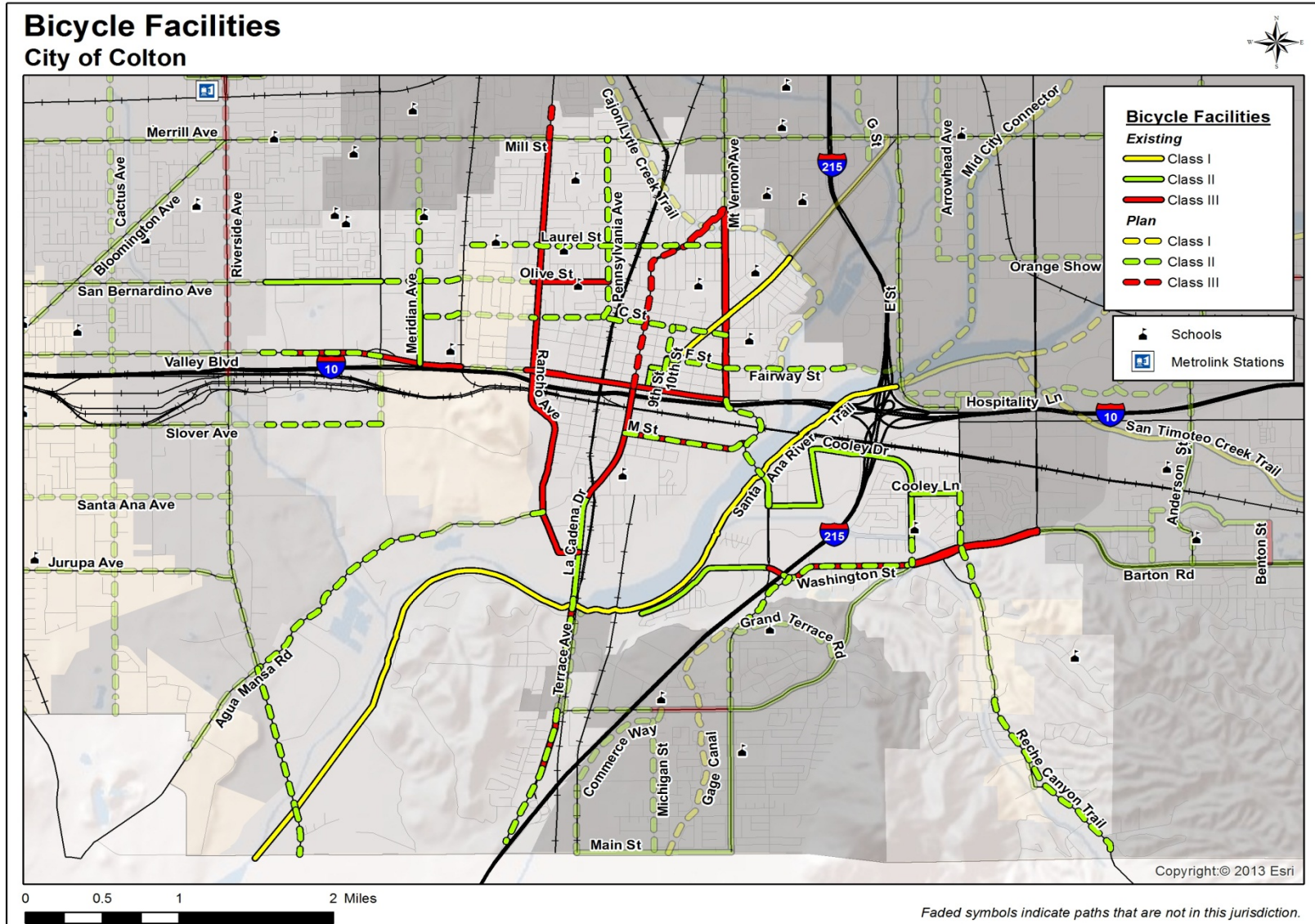

Figure 5.14



The City has also striped 5.85 miles of striped Class II bike lanes, mostly on major transportation corridors throughout the City. The bike lanes provide connectivity to commercial, residential, educational and recreational amenities throughout the city. Finally, the Class I and II facilities are augmented by Class III bike routes throughout the City. The City has 13.71 miles of designated bike routes in the City.

Table 5.35

Colton Existing Conditions

Street/Path	From	To	Class	Length (mi.)	Cost Estimate
9th St.	G St.	Valley Blvd.	II	0.15	\$7,500
Barton Rd.	Washington St.	Waterman Ave.	III	1.70	\$25,500
Colton Ave. Bike Path	N City Limits	G St.	I	1.12	\$1,120,000
Cooley Dr.	Mt Vernon Ave.	Old Ranch Rd.	II	1.90	\$95,000
Cooley Ln.	Cooley Dr.	Hunts Ln.	II	0.32	\$16,000
G St.	9th St.	Colton Ave.	II	0.09	\$4,500
La Cadena Dr.	Barton Rd.	La Loma Ave.	III	0.41	\$6,150
La Cadena Dr.	BNSF RR	Santa Ana River Bridge	II	0.78	\$39,000
La Cadena Dr.	Santa Ana River Bridge	Litton Ave.	III	0.43	\$6,450
La Cadena Dr.	Valley Blvd.	BNSF RR	III	0.84	\$12,600
M St.	La Cadena Dr.	Mt Vernon Ave.	III	0.81	\$12,150
Meridian Ave.	Valley Blvd.	San Bernardino Ave.	II	0.58	\$29,000
Mt Vernon Ave.	Santa Ana River Bridge	Cooley Dr.	II	0.34	\$17,000
Mt Vernon Ave.	Valley Blvd.	La Cadena Dr.	III	2.24	\$33,600
Olive St.	w/o Rancho Ave.	Pennsylvania Ave.	III	0.49	\$7,350
Rancho Ave.	Mill St.	Valley Blvd.	III	1.64	\$24,600
Rancho Ave.	Valley Blvd.	La Cadena Dr.	III	1.50	\$22,500
San Bernardino Ave.	Pepper Ave.	Sycamore Ave.	II	0.75	\$37,500
Santa Ana River Trail	Riverside County Line	I-10	I	6.15	\$6,150,000
Valley Blvd.	w/o Rancho Ave.	Mt Vernon Ave.	III	1.53	\$22,950
Valley Blvd.	Wildrose Ave.	e/o Hermosa Ave.	III	1.14	\$17,100
Washington St.	Mt Vernon Ave.	Barton Rd.	III	0.98	\$14,700
Washington St.	West terminus	Mt Vernon Ave.	II	0.94	\$47,000
			<b>Total</b>	<b>26.83</b>	<b>\$7,768,150</b>

*Growth/Past investment in system*

Since the San Bernardino County Non-Motorized Transportation Plan was first prepared in 2001, the City of Colton has constructed 7.3 miles of Class I, 5.8 miles of Class II and 13.7 miles of Class III facilities at a rate of 2.98 miles per year.

*Past Investment in Non-Motorized Infrastructure*

The improvements included in Table 5.35 above constitute a significant investment into the non-motorized transportation infrastructure of Colton. Based on planning level estimates, the value of the improvements implemented throughout the City is \$7,768,150.

**Proposed Improvements**

Future improvements to the non-motorized network for the City of Colton will continue along the major transportation corridors throughout the City. All future improvements focus on further development of additional Class II facilities. A table of future improvements is included in Table 5.36 below. When complete, the City will have constructed an additional 16.68 miles of Class II and III, providing a significant upgrade to the density and connectivity of the bicycle network in the City.

The City of Colton has identified the bike route segment listed on Table 5.37 as its top 5 priority. These priority segments have connectivity to Santa Ana River Regional Trail.

Table 5.36

Colton Future Improvements

Street/Path	From	To	Class	Length (mi.)	Cost Estimate
10 <sup>th</sup> St.	C St.	G St.	II	0.30	\$15,000
Agua Mansa Rd.	County Limit	Rancho Ave.	II	0.07	\$3,500
Agua Mansa Rd.	Riverside Ave.	County Limit	II	1.55	\$77,500
C St.	County Limit	Mt Vernon Ave.	II	1.27	\$63,500
C St.	Meridian Ave.	County Limit	II	0.26	\$13,000
Cooley Dr.	Old Ranch Rd.	Washington St.	II	0.17	\$8,500
F St.	10th St.	Mt Vernon Ave.	II	0.39	\$19,500
Fairway St.	Mt Vernon Ave.	Auto Plaza Dr.	II	0.76	\$38,000
Hunts Ln.	Cooley Ln.	Washington St.	II	0.38	\$19,000
La Cadena Dr.	Barton Rd.	I-215	II	0.98	\$49,000
La Cadena Dr.	Mt Vernon Ave.	Valley Blvd.	III	1.83	\$27,450
La Cadena Dr.	Santa Ana River	Litton Ave.	II	0.47	\$23,500
Laurel St.	Theresa Ave.	Mt Vernon Ave.	II	1.63	\$82,000
M St.	La Cadena Dr.	Mt Vernon Ave.	II	0.81	\$40,500
Meridian Ave.	San Bernardino Ave.	Randall Ave.	II	0.50	\$25,000
Mt. Vernon Ave.	Valley Blvd.	M St.	II	0.72	\$36,500
Mt. Vernon Ave.	Washington St.	N of Grand Terrace Rd.	II	0.46	\$23,000
Olive St.	Meridian St.	La Cadena Ave.	II	0.25	\$12,500
Pennsylvania Ave.	Mill St.	C St.	II	1.26	\$63,000
Rancho Ave.	Mills St.	N City Limit	III	0.26	\$4,000
Reche Canyon Trail	County Limit	Riverside County Line	II	1.38	\$69,000
Reche Canyon Trail	Washington Dr.	County Limit	II	0.38	\$19,000
Riverside Ave.	Agua Mansa Rd.	Santa Ana River Bridge	II	1.02	\$51,000
Riverside Ave.	Santa Ana River Bridge	Riverside County Line	II	0.32	\$16,000

San Bernardino Ave.	W. City Limit	Meridian St.	II	0.25	\$12,500
Slover Ave.	Sycamore Ave.	Pepper Ave.	II	0.73	\$36,500
Valley Blvd.	W. City Limit	Pepper Ave.	II	0.87	\$43,500
Washington St.	I-215	Barton Rd.	II	0.87	\$43,500
			<b>Total</b>	<b>20.14</b>	<b>\$934,950</b>

Table 5.37

Priority Improvements

Street/Path	From	To	Class	Length (mi.)	Cost Estimate
La Cadena Dr.	Barton Rd.	I-215	II	0.98	\$49,000
La Cadena Dr.	Mt Vernon Ave.	Valley Blvd.	III	1.83	\$27,450
La Cadena Dr.	Santa Ana River	Litton Ave.	II	0.47	\$23,500
Riverside Ave.	Agua Mansa Rd.	Santa Ana River Bridge	II	1.02	\$51,000
Riverside Ave.	Riverside County Line	Santa Ana River	II	0.32	\$16,000
			<b>Total</b>	<b>4.62</b>	<b>166,950</b>

**Municipal Code**

The municipal code for the City of Colton does not currently include the mandatory requirement for the inclusion of non-motorized serving infrastructure as part of the site design process.

**End of Trip Facilities**

The City of Colton has bike racks dispersed throughout the City, typically at retail centers, schools and multi-unit housing complexes.

The City is upgrading an existing bike trail staging area at the southwest corner of La Cadena Drive and Santa Ana River. The improvements for this facility will provide paved parking, restrooms, picnic tables, shade structures, landscaping/irrigation and other amenities.

**Multimodal Connectivity**

The City of Colton does not have any multimodal facilities that interface with the non-motorized transportation system.

## Collisions Involving Bicyclists

Table 5.38

### Data for Collisions Involving Bicyclists

Parameter	Collision Rate
Total # of Bicycle Collisions from 2007-2011	33
Total # of Bicycle Fatalities from 2007-2011	0
Total # of Bicycle Injuries from 2007-2011	25
Average # of Bicycle Collisions Per Year	6.6
Average Bicycle Collision Rate per 1000/year <sup>1</sup>	0.13

Notes:

1. Rate is calculated using SWITRS collision data and population figures by the California Department of Finance.

## Safety and Education Programs

The City of Colton does not currently participate in any bicycle safety or education programs.

## City of Fontana

### **Population**

212,000

### **City Overview**

Fontana's history dates back to 1887, when the City's precursor, the town site of Rosena was located in the City's present-day downtown. A.B. Miller, an early agricultural landowner who figures prominently in our City's founding, rededicated Rosena as Fontana in 1913. By the 1930s, the City was largely settled from Baseline to the Santa Fe Railway.

From the beginning, the development of Fontana radiated outward from the downtown. The establishment of the Kaiser Steel Mill changed the character of the community from rural to industrial in 1942. The population and intensity of development increased dramatically in the next decade, and consequently, the City incorporated as Fontana in 1952. The City is now home to over 200,000 people in an incorporated area encompassing over 43 square miles, with another approximately 9 square miles in its sphere of influence.

Fontana's economy has continued to diversify, with steel production playing less of a role since the 1984 closure of Kaiser Steel, and the rise of the trucking and distribution industries. The City is now among the fastest growing communities in the Inland Empire, with residential and commercial development continuing to move northward, due in part to the supply of vacant land there, and the access provided to it by the newly constructed SR-210 freeway and I-15.

### **Land Use**

In the early 1900s, Fontana was a diversified agricultural community, producing major commodities such as citrus, grain, grapes, poultry, and swine. In 1942, the area began to transition to a more industrial base with the founding of the Kaiser Steel Mill.

Today, Fontana is both a bedroom community, with a commuting population of workers, and, due to its suburban location near several major freeway and rail transportation corridors, is also a major Inland Empire hub of warehousing and distribution centers. These uses are located primarily in the City's southern half, adjacent to the I-10 corridor. There is also some concentration of these uses near Cherry Ave. and Baseline. Heavy industrial areas surround the former Kaiser Steel (now California Steel) within the City's sphere of influence, and along the I-10 corridor between Valley Blvd and Slover Ave.

A range of residential neighborhoods has developed in the City. The established single and multi-family residential neighborhoods and commercial core of Fontana is largely contained between Baseline and Valley Boulevard. Newer residential development is occurring along the northern edge of the City west of the I-15 freeway, and radiating north and south of the SR 210 corridor. A large portion of Fontana, north of the SR 210 still remains to develop as a mix of planned communities and job centers. Nearly one-quarter of the acreage within the City and its sphere is vacant.

**Existing Conditions:**

Fontana's non-motorized bicycle network has expanded significantly since the last update to the Non-Motorized Transportation Plan. Now complete, the Pacific Electric Trail is one continuous Class I trail from Fontana to the Los Angeles County Line. With the completion of the Pacific Electric Trail, 21.29 miles of Class I bikeways will exist in Fontana.

The City has striped 31.65 miles of Class II bike lanes, mostly on major transportation corridors throughout the City. Not including the Pacific Electric Trail, there also exists 14.76 miles of Class I facilities. The bike lanes provide connectivity to commercial, residential, educational and recreational amenities throughout the city.

*Past Investment in Non-Motorized Infrastructure*

The improvements included in Table 5.39 constitute a significant investment into the non-motorized transportation infrastructure of Fontana. Based on planning level estimates, the value of the improvements implemented throughout the City is \$22,872,000.



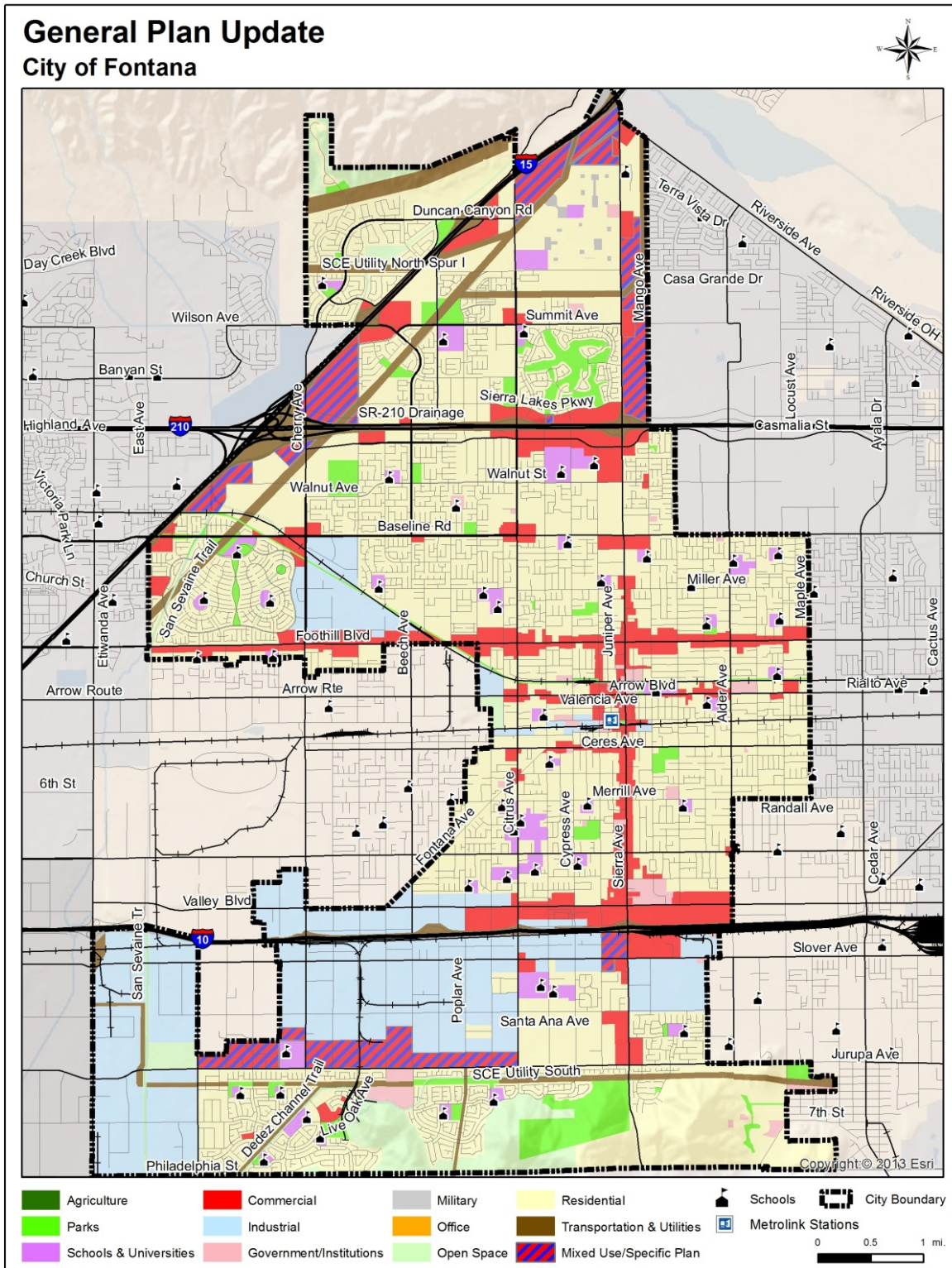
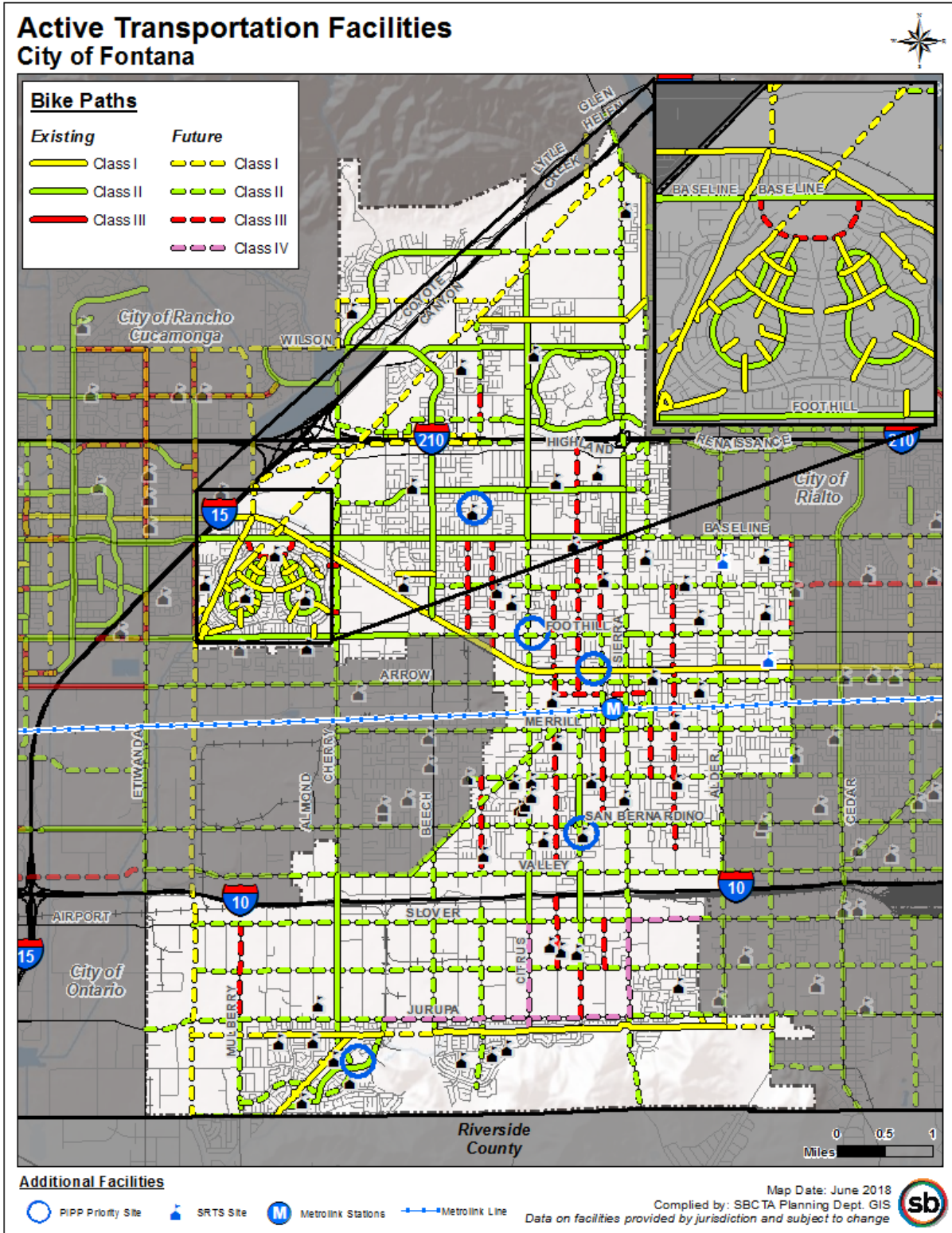

Figure 5.15



C:\Users\christopher\Documents\Projects\BikePlan\_Feb16start\DataDrivenMaps\ATP\_Portrait\_Fontana.mxd

Figure 5.16

Table 5.39

Fontana Existing Conditions

Street/Path	From	To	Class	Length (mi.)	Cost Estimate
Augusta Dr. E	Sierra Lakes Pkwy.	Hacienda Way	II	1.01	\$50,500
Augusta Dr. W	Hacienda Way	Sierra Lakes Pkwy.	II	1.10	\$55,000
Baseline Rd.	East Ave.	Sierra Ave.	II	4.56	\$228,000
Beech Ave.	Cherry Ave.	Pacific Electric Trail	II	3.63	\$181,500
Cherry Ave.	Beech Ave.	Bridlepath Dr. N/Oshawa Dr.	II	0.95	\$47,500
Cherry Ave.	Valley Blvd.	Jurupa Ave.	II	1.52	\$76,000
Citrus Ave.	s/o Duncan Cnyn Rd.	Baseline Ave.	II	3.16	\$158,000
Citrus Ave.	Valley Blvd.	Slover Ave.	II	0.50	\$25,000
Cypress Ave.	Randall Ave.	San Bernardino Ave.	II	0.50	\$25,000
Cypress Ave.	Valley Blvd.	Slover Ave.	II	0.50	\$25,000
Dedez Channel Trail	SCE Utility South	Philadelphia St.	I	1.16	\$1,160,000
Duncan Canyon Rd.	Bridgepath Dr. N/Oshawa Dr.	Lytle Creek Dr. N	II	1.03	\$51,500
E W Heritage Elem Trail	West Heritage Elementary	E Yosemite Loop Rd.	I	0.13	\$130,000
Foothill Blvd.	Cherry Ave.	Hemlock Ave.	II	0.75	\$37,500
Foothill Blvd.	East Ave.	Cherry Ave.	II	1.48	\$74,000
Foothill Blvd.	Sierra Ave.	Midblock from Sierra Ave	II	0.18	\$9,000
Heritage Circle Trail, through park	Caryn Circle	Caryn Circle	I	0.10	\$100,000
Heritage Circle Trail	Caryn Circle	Santa Lucia St.	I	0.07	\$70,000
Heritage Circle Trail	E Liberty Pkwy.	Caryn Circle	I	0.14	\$140,000
Lincoln Loop Rd.	Santa Maria Dr.	Santa Maria Dr.	II	1.42	\$71,000
Live Oak Ave.	Village Dr.	Almond Dr.	II	0.97	\$48,500
Mid-East Heritage Trail	E Grand Ave.	E Lincoln Loop Rd.	I	0.30	\$300,000
Mid-West Heritage Trail	West Heritage Trail	W Grand Ave.	I	0.41	\$410,000
Muirfield Ln.	Citrus Ave.	Augusta Dr.	II	0.07	\$3,500
N East Heritage Elementary Trail	S Heritage Circle	East Heritage Elementary	I	0.36	\$360,000
N East Heritage Trail	W Lincoln Rd.	E Lincoln Loop Rd.	I	0.15	\$150,000
N West Heritage Elem Trail	S Heritage Circle	West Heritage Elementary	I	0.40	\$400,000
N West Heritage Trail	West Heritage Trail	E Yosemite Loop Rd.	I	0.19	\$190,000
Pacific Electric Trail	I-15	Maple Ave.	I	6.52	\$6,520,000
Pacific Electric Trail	Pacific Electric Trail at SCE ROW	Del Norte St.	I	0.09	\$90,000
Path	E Liberty Pkwy.	Foothill Blvd.	I	0.11	\$110,000
Path	W Liberty Pkwy.	Jamestown Circle	I	0.25	\$250,000
Patricia Murray Trail (Loop)	Foothill Blvd.	Foothill Blvd.	I	0.28	\$280,000



Street/Path	From	To	Class	Length (mi.)	Cost Estimate
S W Heritage Elem Trail	Kings Canyon Court	W Liberty Pkwy.	I	0.16	\$160,000
San Sevaine Trail	Baseline Ave.	Foothill Blvd.	I	1.14	\$1,140,000
San Sevaine Trail	Pacific Electric Trail	Baseline Ave.	I	0.23	\$230,000
SCE Utility North	N Riverside Ave.	W Casa Grande Dr.	I	1.30	\$1,300,000
SCE Utility North	Sierra Ave.	Knox Ave.	I	1.53	\$1,530,000
SCE Utility North	W Casa Grande Dr.	Sierra Ave.	I	0.28	\$280,000
SCE Utility South	Beech Ave.	Alder Ave.	I	3.12	\$3,120,000
SCE Utility South	Rancherias Rd.	Live Oak Ave.	I	1.27	\$1,270,000
SE E Heritage Elem Trail	East Heritage Elementary	E Liberty Pkwy.	I	0.21	\$210,000
SE W Heritage Elem Trail	West Heritage Elementary	E Yosemite Loop Rd.	I	0.09	\$90,000
Sierra Ave.	S. Highland Ave.	Baseline Ave.	II	0.83	\$41,500
Sierra Lakes Pkwy.	Catawba Ave.	Sierra Ave.	II	1.29	\$64,500
Sierra Lakes Pkwy.	Sierra Ave.	Mango Ave.	II	0.30	\$15,000
Summit Ave.	Beech Ave.	Sierra Ave.	II	2.15	\$107,500
SW E Heritage Elem Trail	East Heritage Elementary	E Liberty Pkwy.	I	0.23	\$230,000
SW W Heritage Elem Trail	West Heritage Elementary	McKinley Dr.	I	0.07	\$70,000
W W Heritage Elementary Trail	West Heritage Trail	W Liberty Pkwy.	I	0.06	\$60,000
Walkway	Plumaria Dr.	Beech Ave.	I	0.38	\$380,000
Walnut St.	Citrus Ave.	Sierra Ave.	II	2.00	\$100,000
Walnut St.	San Sevaine Rd.	Citrus Ave.	II	0.29	\$14,500
West Heritage Trail	S Heritage Circle	Crocker Ct.	I	0.56	\$560,000
Yosemite Loop Rd.	McKinley Dr.	McKinley Dr.	II	1.46	\$72,500
			<b>Total</b>	<b>53.94</b>	<b>\$22,872,000</b>

### Proposed Improvements

Future improvements to the non-motorized network for the City of Fontana will continue along the major transportation corridors throughout the City. Most of the City's future improvements focus on additional Class II facilities, but some new Class I, Class III, and Class IV facilities are proposed. A table of future improvements is included in Table 5.40 below. At this time the Fontana does not have a priority list of improvements. When complete, however, the City will have constructed 128.59 miles of Class I, II, III, and IV at a total estimated cost of \$36,764,230.

The proposed improvements will provide a significant upgrade to the density and connectivity of the bicycle network in the City.

Table 5.40

Fontana Future Improvements

Street/Path	From	To	Class	Length (mi.)	Cost Estimate
210 Adjacent Path	Victoria St.	Knox Ave.	I	2.46	\$2,460,000
Alder Ave.	Baseline Ave.	Randall Ave.	II	2.51	\$125,500
Alder Ave.	Jurupa Ave.	SCE Utility South	I	0.08	\$80,000
Alder Ave.	Randall Ave.	San Bernardino Ave.	II	0.50	\$25,000
Almeria Ave.	Baseline Ave.	Foothill Blvd.	III	1.02	\$15,300
Almeria Ave.	Foothill Blvd.	Pacific Electric Trail	III	0.16	\$2,400
Arrow Blvd.	Almeria Ave.	Maple Ave.	II	3.15	\$157,500
Baseline Rd.	Sierra Ave.	Maple Ave.	II	1.76	\$88,000
Beech Ave.	Fontana Ave.	Beech Ave. terminus at I-10	II	0.49	\$24,500
Beech Ave.	Slover Ave.	SCE Utility South	II	1.18	\$59,000
Ceres Ave.	Cypress Ave.	Mango Ave.	II	0.74	\$37,000
Cherry Ave.	Baseline Ave.	Foothill Blvd.	II	1.02	\$51,000
Cherry Ave.	Foothill Blvd.	S City Limit	II	0.13	\$6,500
Cherry Ave.	Mulberry Ave.	Jurupa Ave.	II	1.96	\$98,000
Cherry Ave.	N City Limit	Baseline Rd.	II	1.46	\$73,000
Citrus Ave.	Baseline Ave.	Valley Blvd	II	3.52	\$176,000
Citrus Ave.	Duncan Canyon Rd.	S of SCE Utility North	II	0.24	\$12,000
Citrus Ave.	Slover Ave.	SCE Utility South	IV	1.15	\$2,577,150
Connector Path	SCE Utility North Spur	Wilson Ave.	I	0.49	\$490,000
Cypress Ave.	Ceres Ave.	Valley Blvd.	II	1.65	\$82,500
Cypress Ave.	Highland Ave.	Valencia Ave.	III	2.65	\$39,750
Cypress Ave.	Santa Ana Ave.	SCE Utility South	III	0.64	\$9,600
Cypress Ave.	Slover Ave.	Santa Ana Ave.	II	0.50	\$25,000
Duncan Canyon Rd.	Lytle Creek Rd. N	Sierra Ave.	II	1.60	\$80,000
Fontana Ave.	Citrus Ave.	Valley Blvd.	II	1.77	\$88,500
Fontana Ave.	Merrill Ave.	Citrus Ave.	II	0.38	\$19,000
Foothill Blvd.	Hemlock Ave.	Sierra Ave.	II	2.29	\$114,500
Foothill Blvd.	Midblock from Sierra Ave.	Alder Ave.	II	1.57	\$78,500
Frontage Rd.	Cherry Ave.	San Sevaine Rd.	II	0.51	\$25,500
Highland Ave.	Knox Ave.	Highland Ave. terminus	II	0.39	\$19,500
Highland Ave.	Sierra Ave.	Mango Ave.	I	0.31	\$15,500
Juniper Ave.	Baseline Ave.	Foothill Blvd.	III	1.02	\$15,300
Juniper Ave.	Foothill Blvd.	Merrill Ave.	II	1.00	\$50,000
Juniper Ave.	Merrill Ave.	San Bernardino Ave.	III	1.00	\$15,000
Juniper Ave.	Slover Ave.	Santa Ana Ave.	III	0.50	\$7,500
Jurupa Ave.	Sierra Ave.	Tamarind Ave.	II	0.74	\$37,000
Jurupa Ave.	Beech Ave.	Citrus Ave.	IV	0.99	\$2,218,590
Jurupa Ave.	Citrus Ave.	Sierra Ave.	IV	1.05	\$2,353,050
Jurupa Ave.	Etiwanda Ave.	Mulberry Ave.	II	1.02	\$51,000
Jurupa Ave.	Mulberry Ave.	Live Oak Ave.	II	1.52	\$76,000
Jurupa Ave.	Live Oak Ave.	Beech Ave.	IV	0.53	\$1,187,730
Knox Ave.	Curtis Ave.	Sierra Lakes Pkwy	III	0.25	\$3,750

Street/Path	From	To	Class	Length (mi.)	Cost Estimate
Knox Ave.	SCE Utility North at Knox Ave.	Summit Ave.	II	0.30	\$15,000
Knox Ave.	Sierra Lakes Pkwy.	SR-210 Drainage	II	0.16	\$8,000
Knox Ave.	Summit Ave.	Curtis Ave.	II	0.50	\$25,000
Lime Ave.	Baseline Ave.	Foothill Blvd.	III	1.02	\$15,300
Live Oak Ave.	Almond Dr.	San Sevaine Trail	II	0.31	\$15,500
Live Oak Ave.	Jurupa Ave.	Village Dr.	II	0.30	\$15,000
Locust Ave.	Jurupa Ave.	7th St.	II	0.55	\$27,500
Mango Ave.	Highland Ave.	Baseline Rd.	II	1.00	\$50,000
Mango Ave.	Casa Grande Dr.	Summit Ave.	II	0.50	\$25,000
Mango Ave.	Foothill Blvd.	Merrill Ave.	II	1.00	\$50,000
Mango Ave.	Merrill Ave.	Randall Ave.	III	0.50	\$25,000
Maple Ave.	Baseline Rd.	Randall Ave.	II	2.51	\$125,500
Merrill Ave.	Alder Ave.	Maple Ave.	II	0.75	\$37,500
Merrill Ave.	Catawba Ave.	Citrus Ave.	II	0.24	\$12,000
Merrill Ave.	Citrus Ave.	Sierra Ave.	II	1.03	\$51,500
Merrill Ave.	Mango Ave.	Alder Ave.	II	0.75	\$37,500
Merrill Ave.	Sierra Ave.	Mango Ave.	II	0.25	\$12,500
Metrolink	Catawba Ave.	Maple Ave.	I	3.03	\$3,030,000
Meyer Canyon Dr.	Cherry Ave.	E Liberty Pkwy	III	0.09	\$1,350
Miller Ave.	Beech Ave.	Maple Ave.	II	3.77	\$188,500
Mulberry Ave.	Jurupa Ave.	Philadelphia St.	II	1.01	\$50,500
Mulberry Ave.	Slover Ave.	Jurupa Ave.	III	1.01	\$15,150
Oleander Ave.	Arrow Hwy	Orange Way	III	0.24	\$3,600
Oleander Ave.	Ceres Ave.	Valley Blvd.	III	1.62	\$24,300
Oleander Ave.	Miller Ave.	Arrow Hwy	III	1.00	\$15,000
Oleander Ave.	RR	Santa Ana Ave.	III	0.73	\$10,950
Orange Way	Juniper Ave.	Mango Ave.	II	0.50	\$25,000
Philadelphia St.	San Sevaine Trail	Dedez Channel Trail	II	0.88	\$44,000
Palmetto Ave.	Merrill Ave.	Marygold Ave.	III	1.25	\$18,750
Palmetto Ave.	Miller Ave.	Merrill Ave.	III	1.50	\$22,500
Path	Railroad Yard	Philadelphia St.	I	2.15	\$2,150,000
Poplar Ave.	Boyle Ave.	Beech Ave.	II	1.87	\$93,500
Poplar Ave.	Randall Ave.	Valley Blvd.	III	1.00	\$15,000
Randall Ave.	Alder Ave.	Maple Ave.	II	0.75	\$37,500
Randall Ave.	Citrus Ave.	Alder Ave.	II	2.04	\$102,000
Randall Ave.	Lime Ave.	Citrus Ave.	II	0.62	\$31,000
Roanoke Rd.	Cherry Ave.	E Liberty Pkwy	III	0.08	\$1,200
San Bernardino Ave.	Fontana Ave.	Alder Ave.	II	2.78	\$139,000
San Sevaine Rd.	SCE Utility North	SR-10 Drainage	II	0.21	\$10,500
San Sevaine Trail	Foothill Blvd.	S. City Limit	I	0.13	\$130,000
San Sevaine Trail	Pacific Electric Trail at Heritage Circle	Victoria St	I	0.35	\$370,000
Santa Ana Ave.	Almond St.	Tamarind Ave.	II	4.05	\$202,500
Santa Ana Ave.	Mulberry Ave.	Almond Ave.	II	0.77	\$38,500
Santa Ana Ave.	San Sevaine Trail	Mulberry Ave.	II	0.48	\$24,000
SCE Utility North	Crocker Ct.	East Ave.	I	0.36	\$360,000
SCE Utility North	Pacific Electric Trail at SCE ROW	S Heritage Circle	I	0.39	\$390,000



Street/Path	From	To	Class	Length (mi.)	Cost Estimate
SCE Utility North	SCE Utility North Spur I	Pacific Electric Trail at SCE ROW	I	3.34	\$3,340,000
SCE Utility North	Sierra Ave.	SCE Utility North Spur I	I	1.91	\$1,910,000
SCE Utility North Spur I	W. City Limit	SCE Utility North	I	1.66	\$1,660,000
SCE Utility North Spur II	Lytle Creek Rd.	SCE Utility North	I	0.62	\$620,000
SCE Utility South	Alder Ave.	Locust Ave.	I	0.50	\$500,000
SCE Utility South	Live Oak Ave.	Beech Ave.	I	0.56	\$560,000
SCE Utility South	Path	Rancherias Dr.	I	0.80	\$800,000
S Heritage Circle	Baseline Ave.	Baseline Ave.	III	0.70	\$10,500
Sierra Ave.	Baseline Ave.	Slover Ave.	II	4.02	\$201,000
Sierra Ave.	Jurupa Ave.	S. City Limit	II	1.02	\$51,000
Sierra Ave.	Santa Ana Ave.	Jurupa Ave.	IV	0.51	\$1,142,910
Sierra Ave.	Slover Ave.	Santa Ana Ave.	IV	0.50	\$1,120,500
Sierra Ave.	Lytle Creek Rd.	Sierra Lakes Pkwy.	II	3.21	\$160,500
Sierra Ave.	Sierra Lakes Pkwy.	Highland Ave.	II	0.42	\$21,000
Sierra Lakes Pkwy.	San Sevaine Rd.	Catawba Ave.	II	1.37	\$43,500
Slover Ave.	Cherry Ave.	Sierra Ave.	II	3.05	\$152,500
Slover Ave.	Mulberry Ave.	Cherry Ave.	II	1.02	\$51,000
Slover Ave.	San Sevaine Trail	Mulberry Ave.	II	0.49	\$24,500
Slover Ave.	Sierra Ave.	Tamarind Ave.	IV	0.75	\$1,680,750
SR-210 Drainage	San Sevaine Rd.	Knox Ave.	I	0.99	\$990,000
Summit Ave.	Sierra Ave.	Mango Ave.	II	0.25	\$12,500
Tamarind Ave.	Jurupa Ave.	SCE Utility South	I	0.10	\$100,000
Valencia Ave.	Oleander Ave.	Mango Ave.	III	0.99	\$14,850
Valley Blvd.	Banana Ave.	Cherry Ave.	II	0.50	\$25,000
Valley Blvd.	Cherry Ave.	Citrus Ave.	II	2.01	\$100,500
Valley Blvd.	Citrus Ave.	Sierra Ave.	II	1.04	\$54,000
Valley Blvd.	Sierra Ave.	Alder Ave.	II	1.00	\$50,000
Victoria St.	SCE Utility North	Cherry Ave.	II	0.28	\$14,000
Walnut Ave.	Cherry Ave.	San Sevaine Rd.	II	0.50	\$78,500
Walnut Village Pkwy.	Sierra Ave.	Mango Ave.	II	0.25	\$12,500
			<b>Total</b>	<b>128.59</b>	<b>\$36,764,230</b>

Table 5.41

Priority Improvements

Street/Path	From	To	Class	Length (mi.)	Cost Estimate
San Sevaine Trail	Foothill Blvd.	S. City Limit	I	0.13	\$130,000
San Sevaine Trail	Pacific Electric Trail at Heritage Circle	Victoria St	I	0.35	\$370,000
			<b>Total</b>	<b>0.48</b>	<b>\$500,000</b>

## Pedestrian Facilities

The City has also identified opportunities to enhance pedestrian facilities. These are described in the 2017 *SBCTA Safe Routes to School Plan (SRTS)* and in the 2017 *SBCTA Points of Interest Pedestrian Plan (PIPP)*. The *SRTS* focuses on improving access to neighborhood schools listed in Table 5.42, while the *PIPP* focuses on improving access to other community assets listed in Table 5.43. Specific improvement recommendations per project are detailed in the *SRTS Plan Phase II – Volume 2* for items in Table 5.42 and the *PIPP* for items in Table 5.43. Additional potential improvements for *SRTS* or *PIPP* not listed here can be found in the *City of Fontana Active Transportation Plan*, adopted locally November 2017.

Table 5.42  
SRTS Opportunities

Project	Potential Connection to Bikeways, by Status and Class, within ¼ Mile of Project	Number of Improvements Identified	Cost Estimate
Alder M.S.	Planned Class II	10	\$448,799
Ted J. Porter E.S.	Existing Class I & Planned Class II	9	\$498,251
<b>Total</b>		<b>19</b>	<b>\$947,050</b>

Table 5.43  
PIPP Opportunities

Project	Potential Connection to Bikeways, by Status and Class, within ¼ Mile of Project	Proposed Project Ranking
Seville Park along Electric Bike Trail near Civic Center/Library	Existing Class I & Planned Class II, III	1
Southridge Plaza Shopping Center, Southridge Park & Southridge Middle	Existing Class I, II & Planned Class II	2
Almeria Park near Dorothy Grant Elementary	Existing Class II	3
Cypress Elem & Jack Bulik Park	Existing Class II & Planned Class II	4
Citrus Shopping Center Cluster	Planned Class II, III	5
AB Miller High School & Wayne Ruble Middle School	Existing Class II & Planned Class III	NR <sup>A</sup>
Kaiser Fontana Medical Center & Vineyard Valley Shopping Center	Planned Class II	NR <sup>A</sup>
Summit High School & Fontana Park	Existing Class II & Planned Class I, II	NR <sup>A</sup>

TABLE NOTES – <sup>A</sup>: NR = “Not Ranked”, listed as potential project locations and not included in above map.

## **Municipal Code**

Fontana Municipal Code Division 4, Section 30-336(c) provides the following requirements related to pedestrian access and circulation:

### Section 30-336 (c)

#### 1) *Pedestrian*

- a. On-site pedestrian circulation systems shall be provided to meet the movement needs of on-site users. Such systems shall provide safe, all-weather surfaces and aesthetically pleasing means of on-site foot travel. Pedestrian walkways shall be an integrated part of the overall architecture and site design concept.
- b. Pedestrian and bicycle access shall be conveniently provided to connect surrounding land uses and commercial or mixed uses.
- c. All new commercial and mixed-use development shall be accessible to persons with disabilities as required elsewhere in Division 4.
- d. All primary ground-floor common entries and individual dwelling unit entries for mixed-use projects fronting on streets should be oriented to the street, not to the interior or the parking lot.
- e. On-site pedestrian circulation for mixed-use projects should be continuous and connect various uses on the site, as well as connect to off-site transit stops and parking.

### Section 30-342 *General*

- All employers shall provide bicycle parking. There shall be no bike parking on sidewalks unless additional area is provided which does not conflict with sidewalk or entryway. Bicycle and parking facilities should be located in an area of the parking lot convenient to destination entrances for employees as well as for patrons. Bicycle parking facilities should be located in highly visible areas to minimize theft and vandalism and should not interfere with pedestrian traffic. Employees with 100 or more employees shall provide shower and locker facilities to encourage non-motorized travel such as bicycling and walking. Cycle parking facilities should be placed on paved surfaces, well lighted and should be protected from potential damage by other vehicle traffic. All motorcycle parking areas shall be paved with concrete to prevent motorcycle kickstands from damaging the pavement and should be clearly identified for motorcycle usage.

### Section 30-343 *Dimensions*

- Parking racks for bicycles shall be of a size and design which will accommodate the required bicycles. Table 30-343A provides the number of rack by land use type.

## **End of Trip Facilities**

The City of Fontana has bike racks dispersed throughout the City, typically at retail centers, schools and multi-unit housing complexes.

**Multimodal Connectivity**

Table 5.44

Multimodal Connectivity

Facility	Facility Type	Facility Location
Fontana Metrolink Station	Train Station	16777 Orange Way
South Fontana TransCenter	Bus Station	Sierra/Marigold/Valley
City-wide Bus Stops	Bus Stops	Throughout City
Beech PNR	Ride Share Lot	Beech/SR-210
Victoria TMC PNR	Ride Share Lot	13850 Victoria St.

**Collisions Involving Bicyclists**

Table 5.45

Data for Collisions Involving Bicyclists

Parameter	Collision Rate
Total # of Bicycle Collisions from 2012-2016	183
Total # of Bicycle Fatalities from 2012-2016	2
Total # of Injuries from 2012-2016	182
Average # of Bicycle Collisions Per Year	36.6
Average Bicycle Collision Rate per 1000/year <sup>1</sup>	0.17

Notes:

1. Rate is calculated using SWITRS collision data and population figures by the California Department of Finance

**Safety and Education Programs**

The City of Fontana participates in the Police Department’s annual Safety Preparedness Fair, which provides bicycle safety training.

In addition to the annual event sponsored by the Police Department, the following activities take place on a less regular basis:

- The Police Department provides pamphlets available at all events discussing bicycle and pedestrian safety.
- The Police Department will occasionally host “Bicycle Rodeos, which includes a large safety element to the program.
- The Recreation Department will coordinate bike clubs at the elementary and middle schools whose student populations use the PE Trail to commute to school.

## City of Grand Terrace

### Population

12,524

### City Overview

The City of Grand Terrace is the smallest city by population and area in San Bernardino “East Valley.” Incorporated in 1978, the City is located along the southern border of San Bernardino County adjacent to Riverside County and is bounded to the north, east, and west by the City of Colton and to the south by the unincorporated community of Highgrove in Riverside County. The City encompasses approximately 3.6 square miles and has no external sphere of influence.

### Land Use

Grand Terrace is predominantly a residential community. The City was formerly an unincorporated residential enclave surrounded by the City of Colton and unincorporated Riverside County. Although the City is predominately residential, industrial and warehouses are clustered adjacent to Interstate 215. In addition, Barton Road serves as a commercial corridor. Since the majority of the community is located on the west side of Blue Mountain, the terrain offered scenic views that attracted residents.

### Existing Conditions:

Grand Terrace’s existing non-motorized bicycle network is composed of the City’s two major arterial corridors—Barton Road and Mt. Vernon Avenue. The City has striped 3.21 miles of Class II bike lanes and 0.50 miles of Class III bike routes throughout the City.

#### *Growth/Past investment in system*

Since the San Bernardino County Non-Motorized Transportation Plan was first prepared in 2001, the City of Grand Terrace has constructed 3.2 miles of Class II and 0.5 miles of Class III facilities at a rate of 0.36 miles per year.

#### *Past Investment in Non-Motorized Infrastructure*

The improvements included in Table 5.46 constitute a significant investment into the non-motorized transportation infrastructure of Grand Terrace. Based on planning level estimates, the value of the improvements implemented throughout the City is \$882,650.

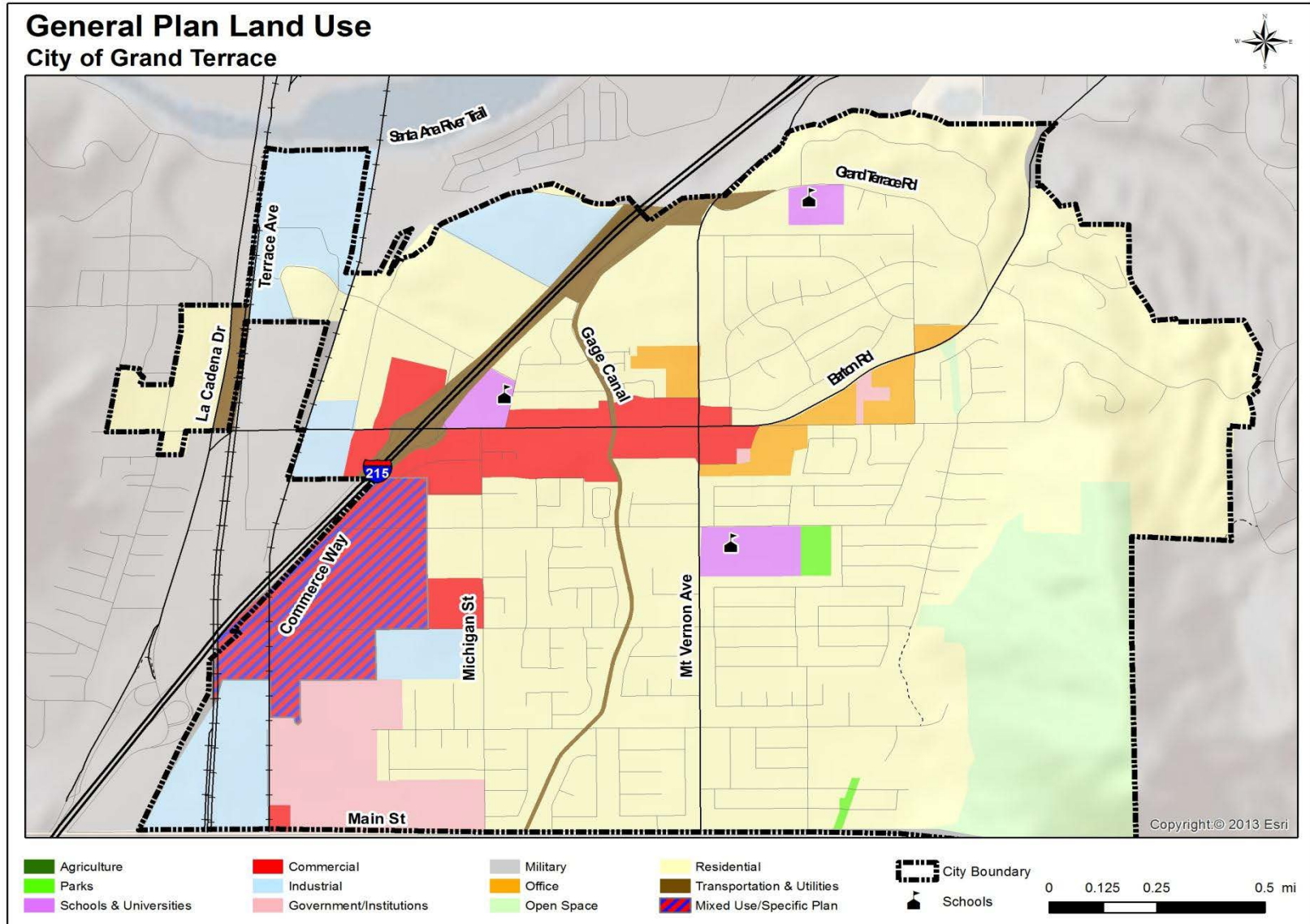

Figure 5.17



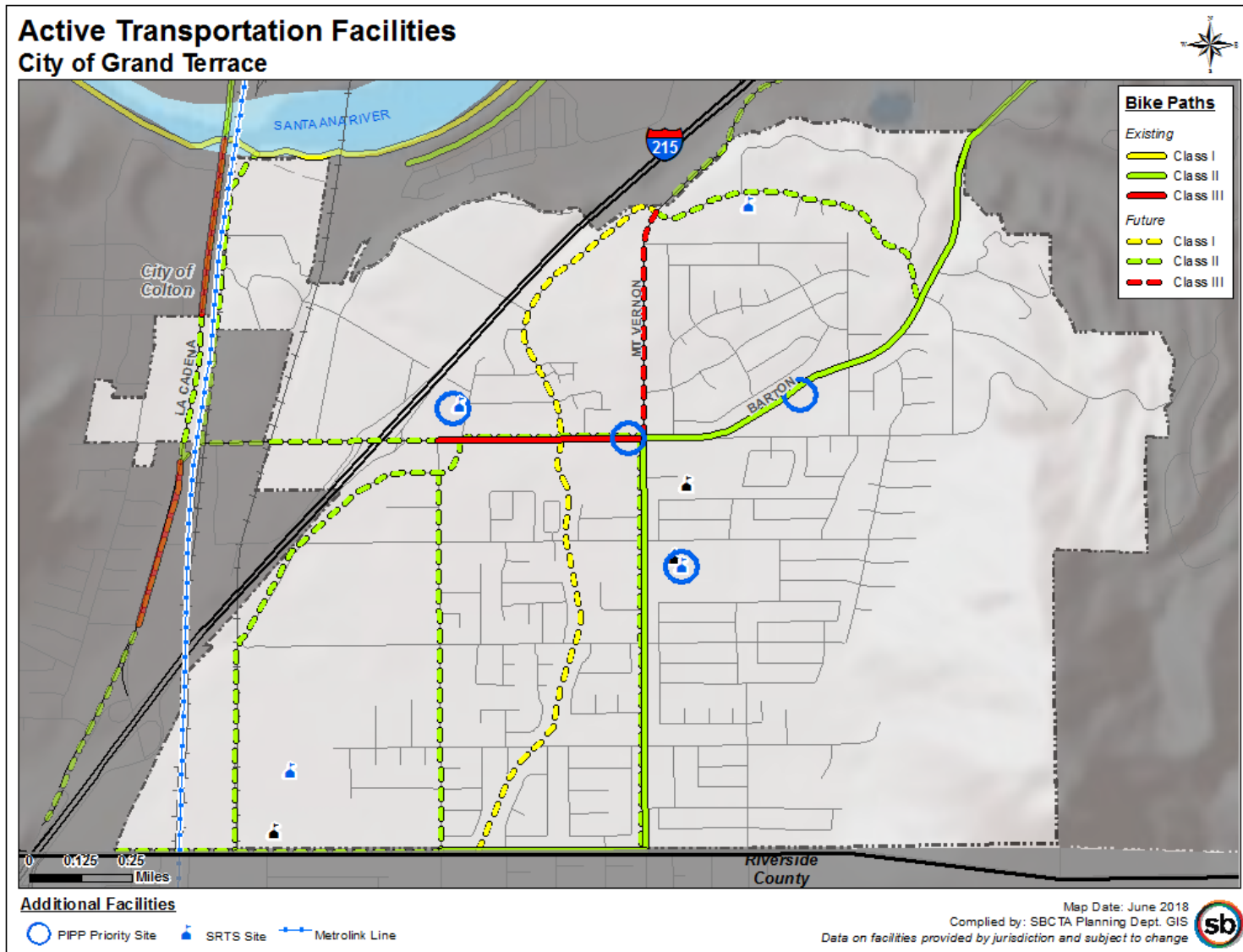

Figure 5.18

Table 5.46

Grand Terrace Existing Conditions

Street/Path	From	To	Class	Length (mi.)	Cost Estimate
Barton Rd.	Michigan St.	Mt Vernon Ave.	III	0.50	\$7,500
Barton Rd.	Mt Vernon Ave.	Washington St.	II	1.70	\$85,000
City Hall Staging Area	Barton Rd.		n/a	n/a	\$150,000
E. City Limits Staging Area	Barton Rd.	E. City Limits	n/a	n/a	\$150,000
Main St.	Michigan St.	Mt Vernon Ave.	II	0.50	\$25,000
Mt Vernon Ave.	Barton Rd.	Main St.	II	1.01	\$15,150
Staging Area	Barton Rd.	Grand Terrace Rd.	n/a	n/a	\$150,000
Staging Area	Mt Vernon Ave.	Main St.	n/a	n/a	\$150,000
Terrace Hills Middle School Staging Area	DeBerry St.	Mt Vernon Ave.	n/a	n/a	\$150,000
			<b>Total</b>	<b>3.71</b>	<b>\$882,650</b>

**Proposed Improvements**

Future improvements to the non-motorized network for the City of Grand Terrace will continue along the major transportation corridors throughout the City. All future improvements focus on development of Class I and Class II facilities. All proposed future improvements are included in Table 5.47 below.

The priority improvements for the City of Grand Terrace include Mount Vernon Ave., Barton Rd., Commerce Way and Michigan St. When complete, the City will have constructed an additional 8.88 miles of Class I and Class II, providing additional connectivity to communities in the East San Bernardino Valley and the County of Riverside.

Table 5.47

Grand Terrace Future Improvements

Street/Path	From	To	Class	Length (mi.)	Cost Estimate
Barton Rd.	La Cadena Dr.	Vivienda St.	II	0.70	\$35,000
Barton Rd.	Vivienda St.	Mt Vernon Ave.	II <sup>A</sup>	0.45	\$22,500
Cage Park Stage Area	Main St.	Taylor St.	n/a	n/a	\$150,000
Commerce Way	Barton Rd.	Main St.	II	0.80	\$40,000
Gage Canal	Mt Vernon Ave.	Main St.	I	1.84	\$1,840,000
Grand Terrace Rd.	Mt Vernon Ave.	Barton Rd.	II	0.77	\$38,500
La Cadena Dr.	Litton Ave.	Palm Ave	II	0.31	\$15,910
Main St.	Michigan St.	Riverside Canal	II	0.79	\$39,500
Michigan St.	Commerce Way	Main St.	II	0.93	\$46,500
Mt Vernon Ave.	Barton Rd.	Main St.	II <sup>A</sup>	1.01	\$50,500
Mt Vernon Ave.	Grand Terrace Rd.	Barton Rd.	II	0.56	\$8,400
Terrace Ave.	Barton Rd.	Santa Ana River Trail	II	0.72	\$36,000
			<b>Total</b>	<b>6.69</b>	<b>\$2,232,910</b>

TABLE NOTES – <sup>A</sup>: Jurisdiction lists existing paths along routes, however will be adding Class IIB paths.

Table 5.48

Priority Improvements

Street/Path	From	To	Class	Length (mi.)	Cost Estimate
Barton Rd.	La Cadena Dr.	Vivienda St.	II	0.70	\$35,000
Barton Rd.	Vivienda St.	Mt Vernon Ave.	II <sup>A</sup>	0.45	\$22,500
Commerce Way	Barton Rd.	Main St.	II	0.80	\$40,000
Gage Canal	Mt Vernon Ave.	Main St.	I	1.84	\$1,840,000
Michigan St.	Commerce Way	Main St.	II	0.93	\$46,500
Mt Vernon Ave.	Barton Rd.	Main St.	II <sup>A</sup>	1.01	\$50,500
Mt Vernon Ave.	Grand Terrace Rd.	Barton Rd.	III	0.56	\$8,400
			<b>Total</b>	<b>6.29</b>	<b>\$2,042,900</b>

TABLE NOTES – <sup>A</sup>: Jurisdiction lists existing paths along routes, however will be adding Class IIB paths.

**Pedestrian Facilities**

The City has also identified opportunities to enhance pedestrian facilities. These are described in the 2017 *SBCTA Safe Routes to School Plan (SRTS)* and in the 2017 *SBCTA Points of Interest Pedestrian Plan (PIPP)*. The *SRTS* focuses on improving access to neighborhood schools listed in Table 5.49, while the *PIPP* focuses on improving access to other community assets listed in Table 5.50. Specific improvement recommendations per project are detailed in the *SRTS Plan Phase II – Volume 2* for items in Table 5.49 and the *PIPP* for items in Table 5.50. Additional potential improvements for *SRTS* or *PIPP* not listed here can be found in the *City of Grand Terrace Active Transportation Plan*, set for adoption locally toward the end of 2018.

Table 5.49  
SRTS Opportunities

Project	Potential Connection to Bikeways, by Status and Class, within ¼ Mile of Project	Number of Improvements Identified	Cost Estimate
Grand Terrace E.S.	Existing Class III & Planned Class I, II	10	\$102,366
Terrace View E.S	Existing Class II & Planned Class I, II	9	\$107,178
Grand Terrace H.S.	Planned Class II	N/A <sup>A</sup>	---
Terrace Hills M.S	Existing Class II	N/A <sup>A</sup>	---
<b>Total</b>		<b>19</b>	<b>\$209,544</b>

TABLE NOTES – <sup>A</sup>: Not applicable, listed as potential project locations in local plans and not included as part of SBCTA SRTS.

Table 5.50  
PIPP Opportunities

Project	Potential Connection to Bikeways, by Status and Class, within ¼ Mile of Project	Proposed Project Ranking
Loma Linda Church & Terrace Hills Middle/ Richard Rollins Park	Existing Class II	1
Azure Terrace Apts/ Grand Terrace Branch Library	Existing Class II	2
Barton Rd Retail Strip & Institutions	Existing Class II, III	3
Grand Terrace Elementary (near Barton Rd Retail)	Existing Class III & Planned Class I, II	4
Grand Terrace Fitness Park	Planned Class II	NR <sup>A</sup>
Grand Terrace High School & Pico Park	Planned Class II	NR <sup>A</sup>

TABLE NOTES – <sup>A</sup>: NR = “Not Ranked”, listed as potential project locations and not included in above map.

### Municipal Code

In January 1994, the City adopted Ordinance # 147, implementing transportation control measures (TCM's) to reduce air pollutant emissions. The ordinance enacted design standards for new nonresidential and multifamily developments to install bicycle racks and other ancillary facilities.

### End of Trip Facilities

The City of Grand Terrace has bike racks dispersed throughout the City, typically at retail centers, schools and multi-unit housing complexes.

**Multimodal Connectivity**

Table 5.51

Multimodal Connections

Facility	Facility Type	Facility Location
City-wide Bus Stops	Bus Stops	Throughout City

**Collisions Involving Bicyclists**

Table 5.52

Data for Collisions Involving Bicyclists

Parameter	Collision Rate
Total # of Bicycle Collisions from 2012-2016	0
Total # of Bicycle Fatalities from 2012-2016	0
Total # of Bicycle Injuries from 2012-2016	0
Average # of Bicycle Collisions Per Year	0.0
Average Bicycle Collision Rate per 1000/year <sup>1</sup>	0.0

Notes:

1. Rate is calculated using SWITRS collision data and population figures by the California Department of Finance

**Safety and Education Programs**

The San Bernardino County Sheriff's Department, Office of Community Services has developed a thorough bicycle safety and education program targeted for public schools. In the City of Grand Terrace, a Sheriff's Department Community Services Officer visits each school site at least once a month. At these meetings, the Community Services Officer regularly distributes information on bike safety and discusses this topic with the students.

## City of Hesperia

### Population

94,829

### City Overview

Hesperia is located north of the Cajon pass, 35 miles north of San Bernardino, 80 miles northeast of Los Angeles and 195 miles south of Las Vegas, Nevada at the intersection of Highway 395 and Interstate 15. Hesperia is one of four incorporated cities in the Victor Valley region of San Bernardino County. Hesperia's incorporated area and sphere of influence encompasses approximately 110 square miles.

The City of Hesperia is located in a transitional area between the foothills of the San Bernardino Mountains to the south and the Mojave Desert to the north. As a result, the planning area contains a variety of slope conditions, soil types, plant communities and other physical characteristics which vary from south to north. The planning area generally slopes from southwest to northeast, with surface and subsurface flows trending away from the foothills and towards the Mojave River, which flows north towards the City of Barstow. While the foothill areas within Summit Valley contain significant slopes, the majority of the planning area is fairly level.

### Land Use

Existing residential development within the City of Hesperia consists of predominantly single family detached housing on lots of one-half acre or larger. Most of the existing residential lots are located within the core area of the town, generally bounded by Maple Avenue and the Mojave River, and by Bear Valley Road and Rancho Road. Within this core area, the majority of residential lot sizes have traditionally ranged from 18,000 square feet to one acre.

The majority of commercial and industrial land uses are located along Main St., Bear Valley Rd., the BNSF Railroad, Hesperia Rd., and I Ave. The map in Figure 5.17 shows the General Plan land use designations for the City of Hesperia.

### Existing Conditions:

Hesperia's non-motorized bicycle network has expanded significantly since the last update to the Non-Motorized Transportation Plan. A major emphasis of the City has been to include Class II bike lanes as part of its pavement rehabilitation program. Consequently, since 2001, the City has constructed 38.6 miles of Class II bike lanes throughout the City. In addition, the City also contains two small segments of Class I bike paths, a total of 1.08 miles, along 8<sup>th</sup> Ave. and Willow St.



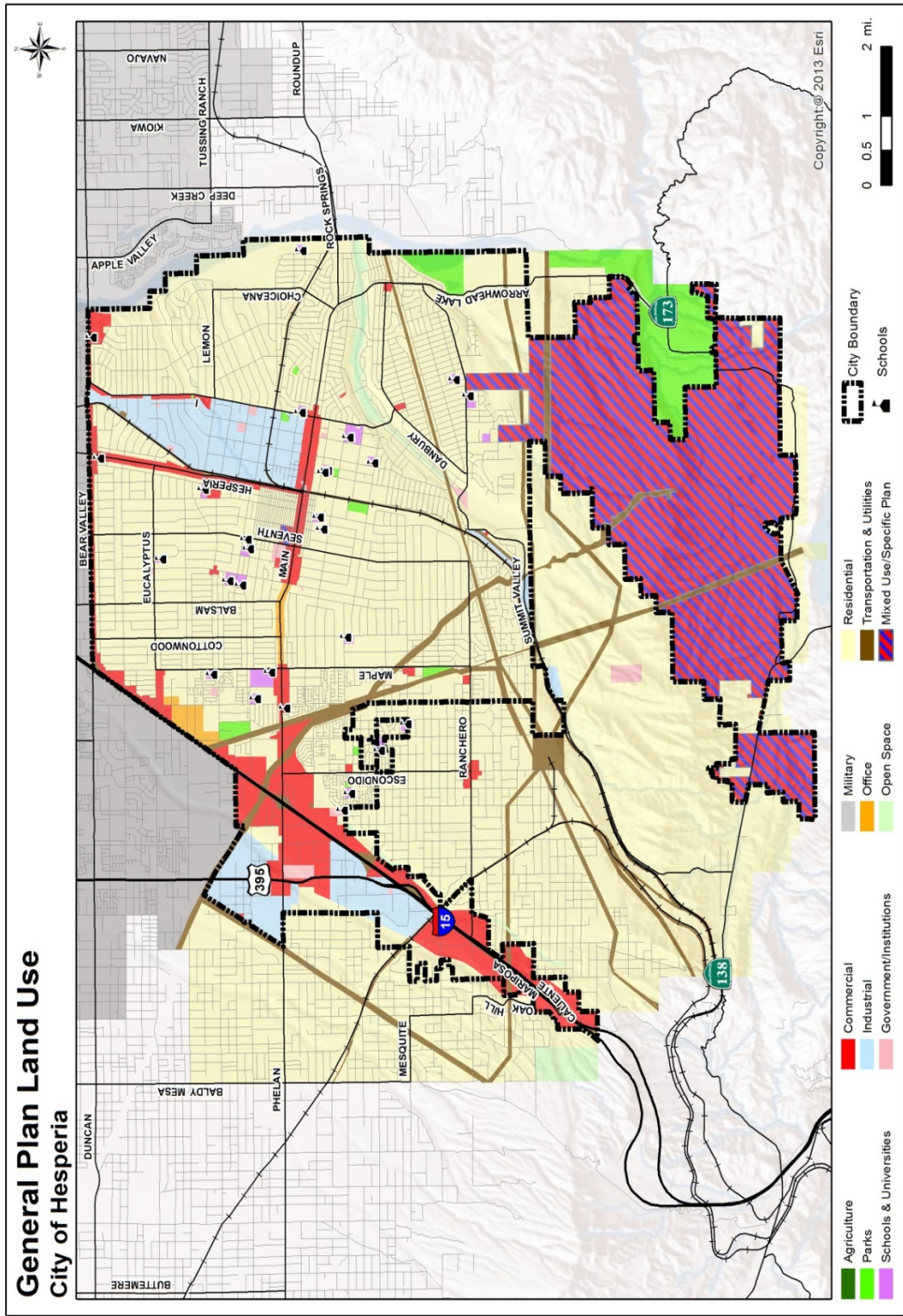
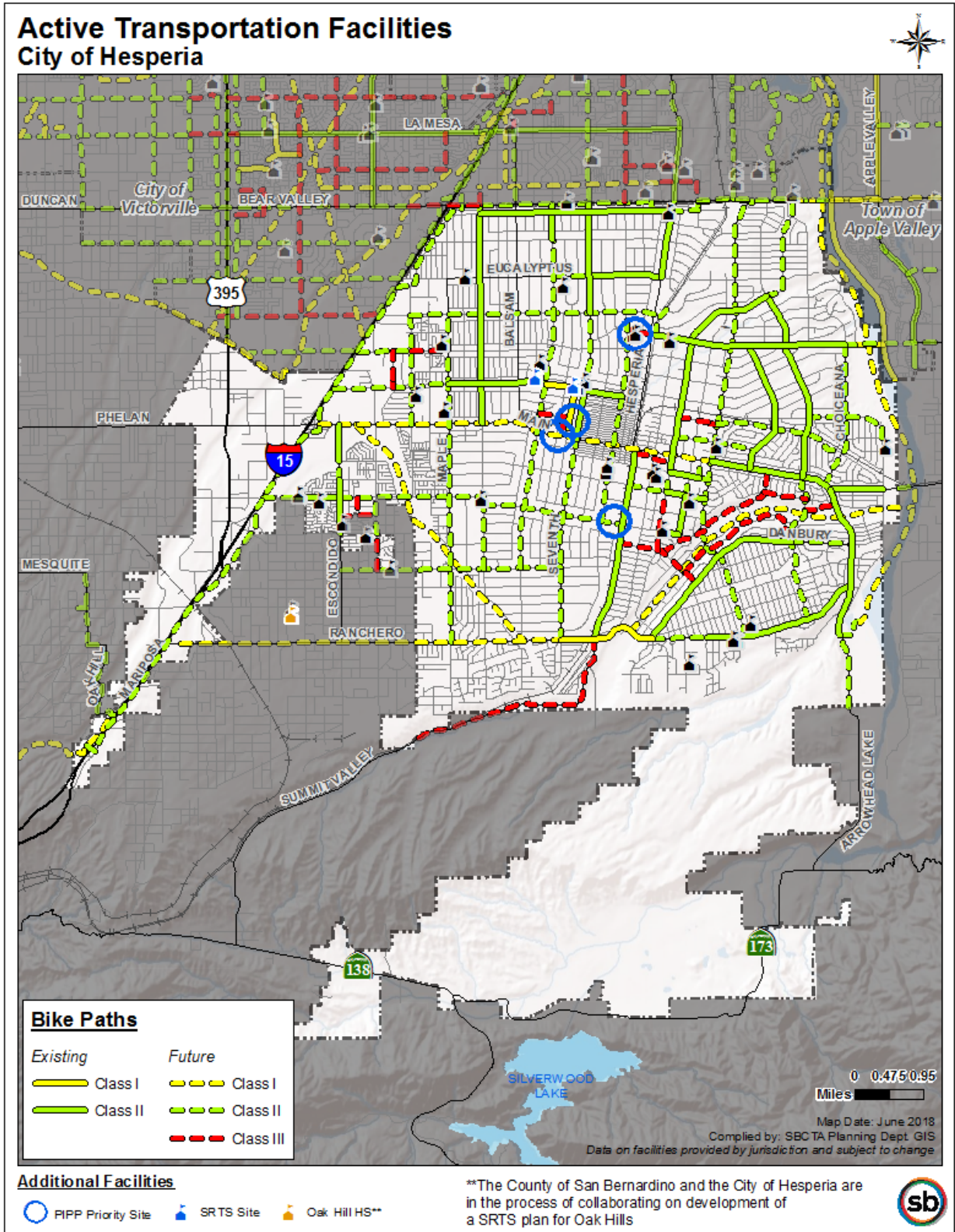

Figure 5.19



C:\Users\christopher\Documents\Projects\BikePlan\_Feb16start\DataDrivenMaps\ATP\_Portrait.mxd

Figure 5.20

Table 5.53

Hesperia Existing Conditions

Street/Path	From	To	Class	Length (mi.)	Cost Estimate
11th Ave.	Bear Valley Rd.	Sycamore St.	II	0.49	\$90,578
7th Ave.	Bear Valley Rd.	Mesa St.	II	1.50	\$277,279
7th Ave.	Willow St.	Main St.	II	0.67	\$123,851
8th Ave.	Willow St.	Juniper St.	I	0.67	\$274,457
Arrowhead Lake Rd.	Main St.	Hesperia Lake Park	II	2.12	\$391,888
Cottonwood Ave.	Sequoia St.	Main St.	II	2.87	\$530,528
Danbury Ave.	Ranchero St.	Peach Ave.	II	2.53	\$467,678
E Ave.	Peach Ave.	Olive St.	II	3.12	\$576,741
Eucalyptus St.	7th Ave.	Hesperia Rd.	II	0.99	\$183,004
Escondido Ave.	Main St.	Sultana St.	II	0.46	\$85,032
Escondido Ave.	Hollister St.	Cedar St.	II	0.78	\$144,185
G Ave.	Sultana St.	Lime St.	II	0.54	\$99,821
Hesperia Rd.	Bear Valley Rd.	Eucalyptus St.	II	1.05	\$194,095
Lemon St.	Santa Fe Ave.	Choiceana Ave.	II	1.56	\$288,370
Lime St.	E Ave.	G Ave.	II	0.27	\$49,910
Main St.	I Ave.	Rock Springs Rd.	II	1.69	\$312,401
Muscatel St.	Vincent Dr.	Escondido Ave.	II	0.62	\$114,609
Olive St.	E Ave.	H Ave.	II	0.42	\$77,638
Peach Ave.	E Ave.	Main St.	II	2.64	\$410,374
Ranchero Rd.	7 <sup>th</sup> Ave.	Danbury Ave.	II	1.27	\$234,763
Ranchero Rd.	Jenkins Ave.	Arrowhead Lake Rd.	II	2.20	\$406,676
Rock Springs Rd.	Main St.	Glendale Ave.	II	1.04	\$192,247
Santa Fe Ave.	Walnut St.	Ranchero Rd.	II	2.63	\$486,163
Sequoia St.	Cottonwood Ave.	Hesperia Rd.	II	2.64	\$488,011
Sultana St.	E Ave.	I Ave.	II	0.54	\$99,821
Timberlane Ave.	Lemon St.	Main St.	II	1.89	\$349,372
Willow St.	11 <sup>th</sup> Ave.	8 <sup>th</sup> Ave.	I	0.41	\$204,595
Willow St.	8 <sup>th</sup> Ave.	3 <sup>rd</sup> Ave.	II	0.66	\$122,003
Willow St.	Maple Ave.	11th Ave.	II	1.35	\$249,551
			<b>Total</b>	<b>39.53</b>	<b>\$7,603,279</b>

*Past Investment in Non-Motorized Infrastructure*

The improvements included in Table 5.53 above constitute a significant investment into the non-motorized transportation infrastructure of Hesperia. Based on planning level estimates, the value of the improvements implemented throughout the City is \$7,603,279.



## Proposed Improvements

Future improvements to the non-motorized network for the City of Hesperia will continue along the major transportation corridors throughout the City. All future improvements focus on further development of additional Class II facilities. A table of future improvements is included in Table 5.54 below.

Table 5.54

### Hesperia Proposed Improvements

Street/Path	From	To	Class	Length (mi.)	Cost Estimate
11th Ave.	Sycamore St.	Mesquite St.	II	4.56	\$842,929
3rd Ave.	Mesa St.	Lime St.	II	2.91	\$537,922
7th Ave.	Main St.	Ranchero Rd.	II	2.79	\$515,739
7th Ave.	Mesa St.	Willow St.	II	1.08	\$199,641
Apatite Ave.	Bear Valley Rd. (Outer HWY)	Sequoia St.	II	0.13	\$24,031
Arrowhead Lake Rd.	Mojave Riverwalk Extension	S City Limit	II	1.03	\$190,398
Bangor Ave.	Joshua St.	Hinton St.	III	1.80	\$14,446
Bear Valley Rd.	Apatite Ave.	City Limits	II	1.80	\$332,735
Bear Valley Rd.	Mariposa Rd.	Bornite Ave.	II	2.61	\$482,466
Bear Valley Rd. (Outer HWY)	Apatite Ave.	Industrial Ave.	II	0.18	\$33,274
Bornite Ave.	Bear Valley Rd.	Sequoia St.	II	0.12	\$22,182
Buckthorn St.	Joshua St.	Main St.	III	1.95	\$15,650
California Aqueduct	Main St.	Ranchero Rd.	I	3.86	\$3,872,352
Centennial St.	Peach Ave.	Arrowhead Lake Rd.	III	0.43	\$3,451
Choceana Ave.	Lemon St.	Main St.	II	2.01	\$371,554
Cottonwood Ave.	Bear Valley Rd.	Sequoia St.	II	0.13	\$24,031
Cottonwood Ave.	Muscatel St.	Mesquite St.	II	1.00	\$184,853
Danbury Ave.	Peach Ave.	Arrowhead Lake Rd.	II	0.83	\$153,428
Datura Ave.	Live Oak St.	Courtney St.	III	0.11	\$883
Datura Ave.	Mojave St.	Courtney St.	III	0.38	\$3,050
Drainage Channel	Mojave River	Ranchero Rd.	I	4.63	\$4,644,816
E Ave.	Olive St.	Sultana St.	II	0.27	\$49,910
E Ave.	Sultana St.	Joshua St.	III	0.81	\$6,501
Escondido Ave.	Sultana St.	Hollister Rd.	II	0.29	\$53,607
Eucalyptus St.	11th Ave.	7th Ave.	II	0.49	\$90,578
Fuente Ave.	Cedar St.	Mesquite St.	III	0.49	\$3,933
Fuente Ave.	Muscatel Rd.	Cedar St.	II	0.50	\$92,426
G Ave.	Olive St.	Sultana St.	II	0.27	\$49,910
H Ave.	Main St.	Olive St.	II	0.24	\$44,365
I Ave.	Bear Valley Rd.	Ranchero Rd.	II	6.34	\$1,171,967
Jacaranda Ave.	Bear Valley Rd.	Peach Ave.	II	1.51	\$279,128
Joshua St.	Santa Fe Ave.	Danbury	III	1.30	\$10,433
Juniper St.	Eleventh Ave.	Seventh Ave.	III	0.54	\$4,334
Lemon St.	First Ave.	Hesperia Rd.	III	0.12	\$963

Street/Path	From	To	Class	Length (mi.)	Cost Estimate
Lemon St.	Riverview Ave.	Mojave Riverwalk	I	0.44	\$441,408
Lemon St.	Choiceana Ave.	City Limits	II	0.49	\$90,578
Lemon St.	Third Ave.	First Ave.	III	0.20	\$1,605
Lime St.	Cottonwood Ave.	Santa Fe Ave.	II	1.90	\$351,220
Live Oak St.	E Ave.	Live Oak Park	III	0.42	\$3,371
Live Oak St.	I Ave.	Choiceana Ave.	II	1.82	\$336,432
Live Oak St.	Live Oak Park	I Ave.	III	0.12	\$963
Live Oak St.	Mariposa Rd.	Maple Ave.	II	1.58	\$292,067
Main St.	Mariposa Rd.	I Ave.	I	5.46	\$2,724,610
Maple Ave.	Mesa St.	Ranchero Rd.	II	4.51	\$833,686
Mariposa Rd.	Bear Valley Rd.	Cajon Pass Trail	II	9.48	\$1,752,405
Mesa St.	Muscatel Rd.	Palm Ave.	III	0.25	\$2,006
Mesa St.	Topaz Ave.	Hesperia Rd.	II	3.36	\$621,105
Mesquite St.	Escondido Ave.	7th Ave.	II	3.02	\$558,255
Mojave Riverwalk	Bear Valley Rd.	Heritage Lake Park	I	6.35	\$6,370,320
Mojave Riverwalk Extension	Arrowhead Lake Rd.	Heritage Lake Park	II	0.40	\$73,941
Mojave St.	Mariposa Rd.	Topaz Ave.	II	0.74	\$136,791
Mojave St.	Topaz Ave.	Maple Ave.	III	0.51	\$4,093
Muscatel Rd.	Escondido Ave.	Cottonwood Ave.	II	1.97	\$364,160
Muscatel Rd.	Mariposa Rd.	Vincent Dr.	II	0.42	\$77,638
Olive St.	H Ave.	I Ave.	II	0.14	\$25,879
Orange St.	Buckthorn Ave.	Peach Ave.	III	0.59	\$4,735
Palm St.	Escondido Ave.	Fuente Ave.	III	0.49	\$3,933
Peach Ave.	Main St.	Ranchero Rd.	II	2.11	\$390,039
Ranchero Rd.	Danbury Ave.	Jenkins Ave.	II	0.75	\$138,640
Ranchero Rd.	Mariposa Rd.	7th Ave.	I	5.25	\$2,619,817
Santa Fe Ave.	Darwin Ave.	Lemon St.	II	0.38	\$70,244
Sequoia St. + Signal	Hesperia Rd.	Apatite Ave.	II	0.36	\$361,152
Smoke Tree St.	11th Ave.	7th Ave.	III	0.54	\$4,334
Smoke Tree St.	E Ave.	Timberlane	II	1.09	\$201,490
Sultana St.	Santa Fe Ave.	E Ave.	II	0.51	\$94,275
Summit Valley Rd.	Ranchero Rd.	past Telephone Canyon	III	3.22	\$25,842
Topaz Ave.	Mesa St.	Main St.	II	1.50	\$277,279
Walnut St.	Santa Fe Ave.	E Ave.	III	0.51	\$4,093
Willow St./Glendale Ave.	Peach Ave.	Benicia St.	II	1.19	\$219,975
			<b>Total</b>	<b>109.58</b>	<b>\$33,806,267</b>

Table 5.55

Priority Improvements

Street/Path	From	To	Class	Length (mi.)	Cost Estimate
7 <sup>th</sup> Ave.	Main St.	Ranchero Rd.	II	2.79	\$515,739
7 <sup>th</sup> Ave.	Mesa St.	Willow St.	II	1.08	\$199,641
Apatite Ave.	Bear Valley Rd. (Outer Highway)	Sequoia St.	II	0.13	\$24,031
Bear Valley Rd (Outer Highway)	Apatite Ave.	Industrial Rd.	II	0.17	\$31,425
Danbury Ave.	Peach Ave.	Arrowhead Lake Rd.	II	0.83	\$153,428
I Ave.	Bear Valley Rd.	Ranchero Rd.	II	6.34	\$1,171,967
Jacaranda Ave.	Bear Valley Rd.	Peach Ave.	II	1.51	\$279,128
Main St.	Mariposa Rd.	I Ave.	I	5.46	\$5,477,472
Mesquite St.	Escondido Ave.	7 <sup>th</sup> Ave.	II	3.02	\$558,255
Ranchero Rd.	Danbury Ave.	Jenkins Ave.	II	0.75	\$138,640
Sequoia St. + sign cross.	Hesperia Rd.	Apatite Ave.	II	0.36	\$361,152
Sultana St.	Santa Fe Ave.	E Ave.	II	0.50	\$92,426
			<b>Total</b>	<b>22.94</b>	<b>\$9,003,304</b>

**Pedestrian Facilities**

The City has also identified opportunities to enhance pedestrian facilities. These are described in the 2017 *SBCTA Safe Routes to School Plan (SRTS)* and in the 2017 *SBCTA Points of Interest Pedestrian Plan (PIPP)*. The *SRTS* focuses on improving access to neighborhood schools listed in Table 5.56, while the *PIPP* focuses on improving access to other community assets listed in Table 5.57. Specific improvement recommendations per project are detailed in the *SRTS Plan Phase II – Volume 2* for items in Table 5.56 and the *PIPP* for items in Table 5.57.

The site of Oak Hills High School, included in Table 5.56, is a forthcoming *SRTS* project site in collaboration locally between the County of San Bernardino and the City of Hesperia. As outlined by their *Oak Hills Community Plan*, the unincorporated community, where the school is located, acknowledges that Oak Hills H.S. may benefit from improved pedestrian facilities to the school as the community plans for the future. This local Plan was initially adopted by the City of Hesperia April 2002 and amended June 2013 by the County and can be viewed by contacting the County. This school site therefore is not included in the *SRTS*.



Table 5.56  
SRTS Opportunities

Project	Potential Connection to Bikeways, by Status and Class, within ¼ Mile of Project	Number of Improvements Identified	Cost Estimate
Hesperia Junior High	Existing Class I, II & Planned Class II	9	\$898,655
Joshua Circle E.S.	Existing Class I, II & Planned Class II	12	\$1,080,391
Oak Hills H.S.	Planned Class I	N/A <sup>A</sup>	---
<b>Total</b>		<b>24</b>	<b>\$1,979,046</b>

TABLE NOTES – <sup>A</sup>: Not applicable, the County of San Bernardino and the City of Hesperia are in the process of collaborating on development of a SRTS plan for this site, and not included as part of SBCTA SRTS.

Table 5.57  
PIPP Opportunities

Project	Potential Connection to Bikeways, by Status and Class, within ¼ Mile of Project	Proposed Project Ranking
Hesperia City Hall, City Services, and Park	Existing Class I, II & Planned Class I, III	1
Hesperia Square Shopping Center or other Main St retail cluster	Planned Class I, III	2
Lime Street Park	Existing Class II & Planned Class II	3
Mojave High & Hesperia Alternative Education	Planned Class II, III	4
Hesperia H.S.	Planned Class I, III	NR <sup>A</sup>
Hesperia Lake Park	Existing Class II & Planned Class I, II	NR <sup>A</sup>
Live Oak Park	Planned Class II, III	NR <sup>A</sup>
Sultana H.S.	Existing Class II & Planned Class II	NR <sup>A</sup>

TABLE NOTES – <sup>A</sup>: NR = “Not Ranked”, listed as potential project locations and not included in above map.

### Municipal Code

The municipal code for the City of Hesperia does not currently include the mandatory requirement for the inclusion of non-motorized serving infrastructure as part of the site design process.

### End of Trip Facilities

The City of Hesperia has bike racks dispersed throughout the City, typically at retail centers, schools and multi-unit housing complexes.

### Multimodal Connectivity

The City of Hesperia has the following multimodal facilities that interface with the non-motorized transportation system.

Table 5.58

Multimodal Connectivity

Facility	Facility Type	Facility Location
Hesperia Blvd PNR Lot	Ride Share Lot	US 395 & Joshua St
Hesperia Transit Center	Multi-Modal Facility	TBD
City-wide Bus Stops	Bus Stops	Throughout City

### Collisions Involving Bicyclists

Table 5.59

Data for Collisions Involving Bicyclists

Parameter	Collision Rate
Total # of Bicycle Collisions from 2012-2016	44
Total # of Bicycle Fatalities from 2012-2016	4
Total # of Bicycle Injuries from 2012-2016	41
Average # of Bicycle Collisions Per Year	8.8
Average Bicycle Collision Rate per 1000/year <sup>1</sup>	0.09

Notes:

1. Rate is calculated using SWITRS collision data and population figures by the California Department of Finance

### Safety and Education Programs

The City of Hesperia does not currently participate in any bicycle safety or education programs.

## City of Highland

### Population

54,761

### City Overview

The City of Highland is currently home to 54,761 residents in an area that is approximately 18 square miles. The City is bordered on the north and east by the San Bernardino Mountains and San Bernardino National Forest and is located adjacent to the Santa Ana River. When Highland incorporated in 1987, the population was 29,500. Since incorporation, Highland's population has grown by approximately 84%. The build-out for the City is estimated to be 75,000 residents—approximately 38% beyond their current population.

Highland's original town site was founded in 1891. The community soon became an important part of the citrus industry—and a number of former packinghouses still exist within the community. The historic Old Town still displays commercial and residential structures from the City's early period. They remain as symbols of the sense of community and respect for tradition that characterize Highland today.

### Land Use

Highland is predominantly a residential community; over 60 percent of the City's 11,948 acres of land is planned for residential development. The dominance of residential lands can be attributed to the circumstances surrounding the City's incorporation. Before incorporation, Highland's land area was in the City of San Bernardino's sphere of influence. Much of the property that would naturally have hosted Highland's retail or industrial uses was annexed to San Bernardino, leaving only those areas that logically could be developed in residential based uses. Additionally, more than 20 percent of the City is designated primarily for open space, due primarily to the City's proximity to the San Bernardino Mountains, the San Bernardino International Airport, the Santa Ana River Basin and City Creek and Plunge Creek running through the southern part of Highland.

### Existing Conditions:

Highland's existing non-motorized bicycle network is composed mainly of the City's three major east-west arterial corridors—9th Street, Base Line and 5<sup>th</sup> Street/Greenspot Road—and four major north-south corridors—Palm Avenue, Boulder Avenue, Weaver Street and Church Street. The City has a combined total of 25.6 miles of Class I and Class II bike lanes throughout the City.

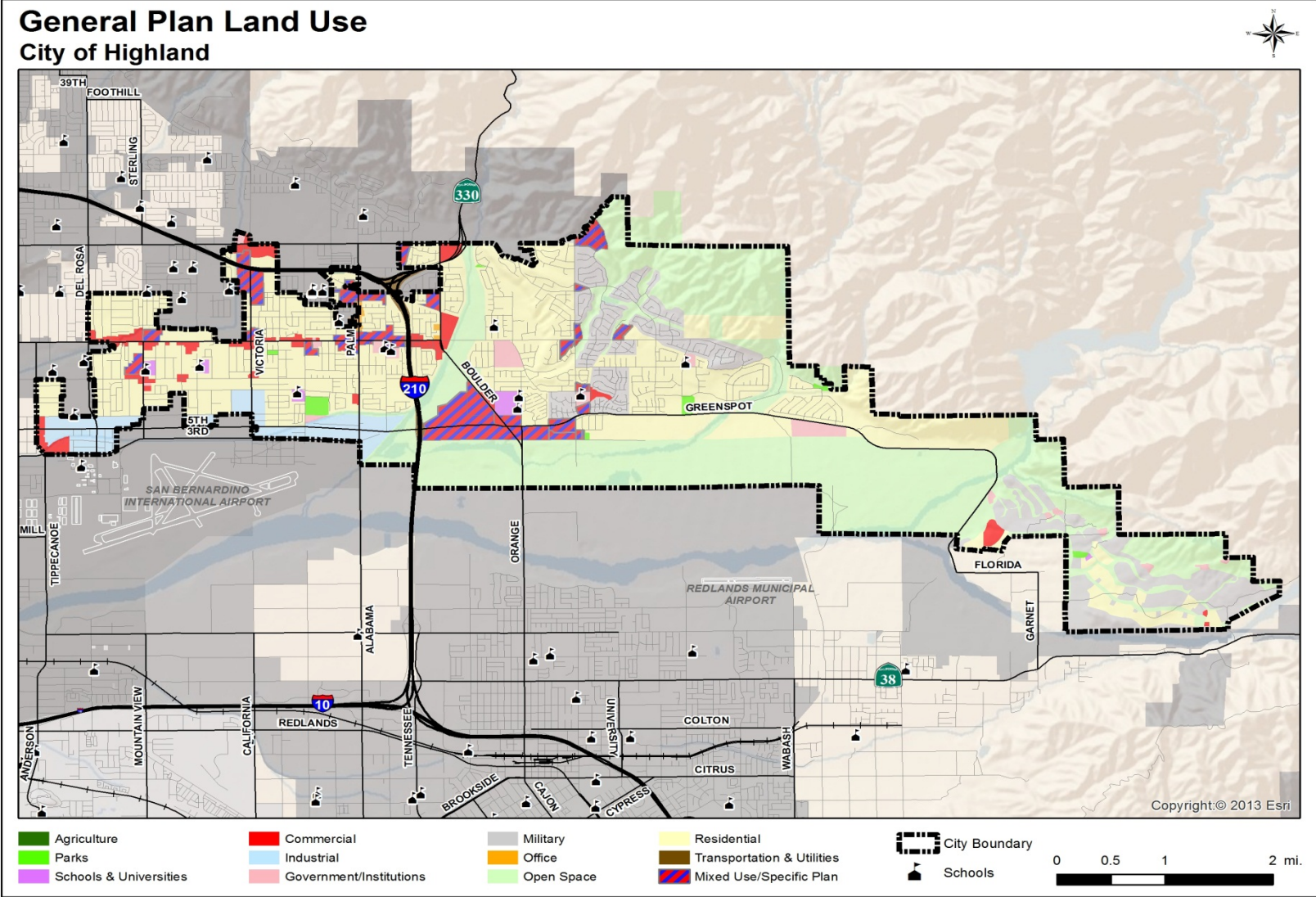
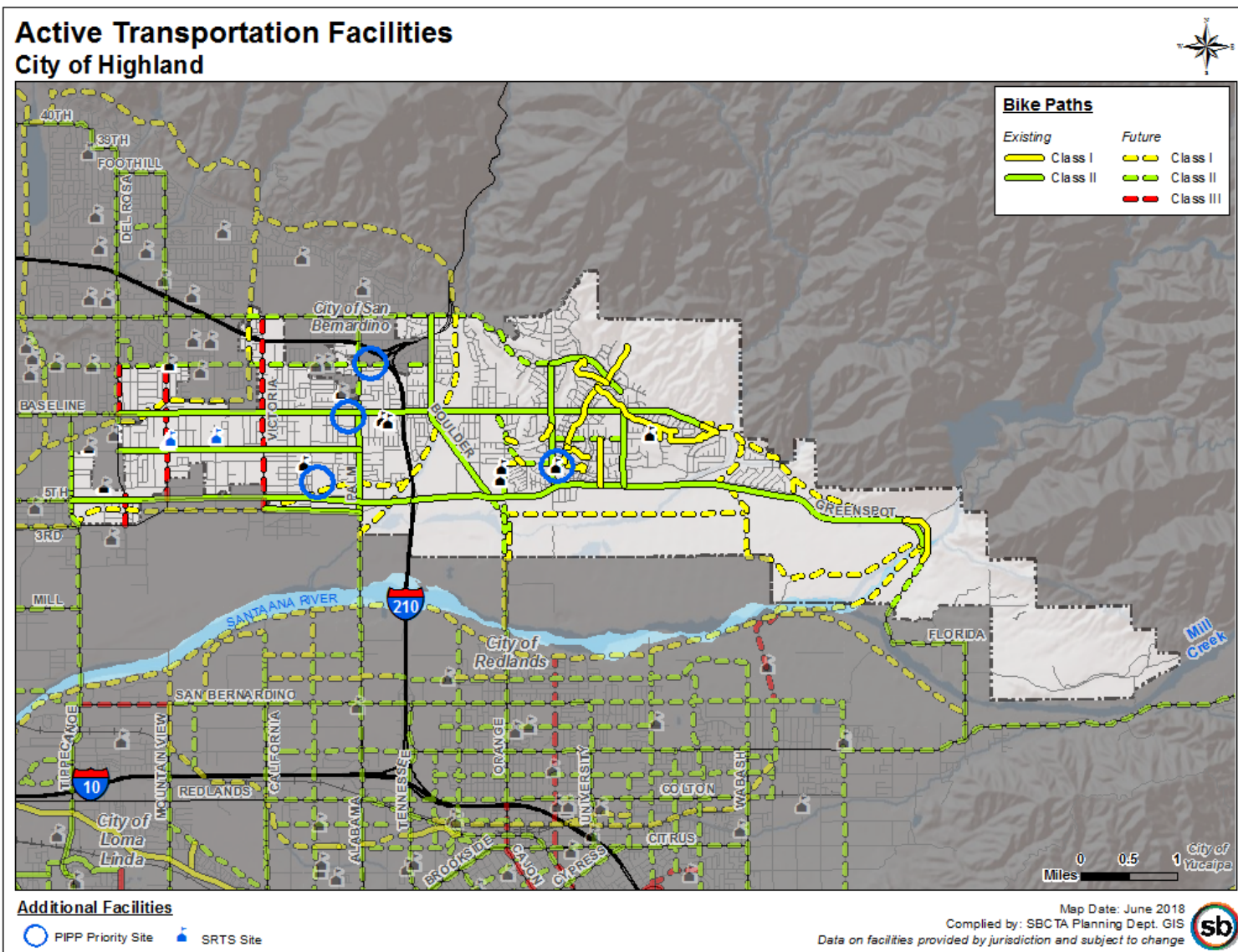

Figure 5.21





C:\Users\christopher\Documents\Projects\BikePlan\_Feb18\start\DataDrivenMaps\ATP\_Landscape.mxd

Figure 5.22

Table 5.60

Highland Existing Conditions

Street/Path	From	To	Class	Length (mi.)	Cost Estimate
3rd St.	Victoria Ave.	Palm Ave.	II	1.00	\$50,000
5th St.	Tippecanoe Ave.	SR-210	II	3.50	\$175,000
9th St.	Del Rosa Dr.	Palm Ave.	II	2.50	\$125,000
Base Line	Del Rosa Dr.	Tuolumne Ln.	II	6.10	\$305,000
Boulder Ave.	Greenspot Rd.	Highland Ave.	II	2.10	\$105,000
Church St.	Greenspot Rd.	Highland Ave.	II	1.30	\$65,000
Greenspot Rd.	SR-210	Santa Ana River	II	5.60	\$280,000
Highland Ave.	Church St.	Weaver St.	II	0.90	\$45,000
Old Greenspot Rd.	New Greenspot Rd.	New Greenspot Rd.	I	0.60	\$600,000
Palm Ave.	3rd St.	Base Line St.	II	1.00	\$50,000
Weaver St.	Greenspot Rd.	Highland Ave.	II	1.00	\$50,000
			<b>Total</b>	<b>25.60</b>	<b>\$1,850,000</b>

*Growth/Past investment in system*

Since the San Bernardino County Non-Motorized Transportation Plan was first prepared in 2001, the City of Highland has constructed 25.6 miles of Class I and Class II facilities at a rate of 1.50 miles per year.

*Past Investment in Non-Motorized Infrastructure*

The improvements included in Table 5.60 above constitute a significant investment into the non-motorized transportation infrastructure of Highland. Based on planning level estimates, the value of the improvements implemented throughout the City is \$1,850,000.

**Proposed Improvements**

Future improvements to the non-motorized network for the City of Highland will continue throughout the City. All proposed future improvements are included in Table 5.61 below.

The priority projects for the City of Highland are included in Table 5.62 below. Priority corridors include Boulder Avenue, Alabama Street, City Creek, Glenheather Drive, Orange Street, Pacific Street, Highland Avenue, Palm Avenue and Santa Ana River Trail Connections at Palm/Alabama Avenue, Boulder/Orange Avenue and Old Greenspot Road.



When complete, the City will have constructed approximately an additional 25.0 miles of bikeways, providing additional internal connectivity to the residents of Highland and increased connectivity to communities in the East San Bernardino Valley.

Table 5.61

Highland Future Improvements

Street/Path	From	To	Class	Length (mi.)	Cost Estimate
Cone Camp Rd.	Greenspot Rd.	S City Limit	I	0.80	\$800,000
Del Rosa Dr.	3rd St.	6th St.	III	0.40	\$6,000
Del Rosa Dr.	Baseline St.	Pacific St.	III	0.50	\$7,500
Greenspot Rd.	Santa Ana River Trail	S City Limit	II	0.50	\$25,000
North Fork Trail	Tuolumne Ln.	Greenspot Rd.	I	1.20	\$1,200,000
Pacific St.	La Praix St.	Boulder Ave.	II	0.25	\$12,500
Plunge Creek Trail	North Fork Trail	Greenspot Rd.	I	0.70	\$700,000
Pole Line Trail	Orange St.	Cone Camp Rd.	I	2.50	\$2,500,000
Santa Ana River	Old Greenspot Rd.	Cone Camp Rd.	I	2.00	\$2,000,000
Sterling St.	5th St.	Pacific St.	III	1.40	\$21,000
Tippecanoe Ave.	3rd St.	9th St.	II	0.90	\$45,000
Victoria Ave.	3rd St.	Highland Ave.	III	2.00	\$30,000
			<b>Total</b>	<b>13.15</b>	<b>\$7,347,000</b>

Table 5.62

Priority Improvements

Street/Path	From	To	Class	Length (mi.)	Cost Estimate
Alabama St.	South City Limit	3rd St.	II	0.20	\$10,000
Alabama St.	South City Limit	North Levee City Creek	I	0.10	\$100,000
Boulder Ave.	Orange St.	Greenspot Rd	II	0.60	\$30,000
City Creek Bypass Trail	3rd St.	City Creek Trail (North Levee)	I	1.50	\$1,500,000
City Creek Trail (North Levee)	Alabama St.	Base Line	I	1.60	\$1,600,000
City Creek Trail (North Levee)	Base Line	Highland Ave.	I	1.00	\$1,000,000
Del Rosa Dr.	3rd St.	6th St.	III	0.40	\$6,000
Del Rosa Dr.	Baseline St.	Pacific St.	III	0.50	\$7,500
Glenheather Dr.	Streater Dr.	Church St.	II	0.30	\$15,000
Highland Ave.	Rockford Ave.	east of Victoria Ave.	II	0.40	\$20,000
Highland Ave.	west of Denair Ave.	Church St.	II	1.90	\$95,000
Lot "Y" Easement	Orange St.	Glenheather Dr.	I	0.20	\$200,000
Love St.	Church St.	East terminus	II	0.10	\$5,000
Orange St.	South City Limit	Boulder Ave.	II	0.60	\$30,000
Orange St.	South City Limit	Plunge Creek Bridge	I	0.70	\$700,000

Street/Path	From	To	Class	Length (mi.)	Cost Estimate
Orange St.	Plunge Creek Bridge	Greenspot Rd.	II	0.10	\$5,000
Orange St.	Greenspot Rd.	Eucalyptus St.	II	0.40	\$20,000
Pacific St.	Del Rosa Dr.	east of Guthrie St.	II	0.80	\$40,000
Pacific St.	La Praix St.	Boulder Ave.	II	0.25	\$12,500
Pacific St.	Orange St.	Church Ave.	II	0.60	\$30,000
Pacific St.	Rockford Ave.	west of Central Ave.	II	0.60	\$30,000
Palm Ave.	Base Line	Atlantic Ave.	II	0.80	\$40,000
Streater Dr.	Base Line	Glenheather Dr.	II	0.60	\$30,000
Streater Dr.	Lot "Y" Easement	Canyon Oak Dr.	I	0.10	\$100,000
Water St.	Church St.	Weaver St.	II	0.80	\$40,000
			<b>Total</b>	<b>15.15</b>	<b>\$5,666,000</b>

TABLE NOTE: Data includes only the portion within the city limits of Highland. Paths need to be extended by other jurisdictions through to Santa Ana River Trail in order to best serve regional users.

### Pedestrian Facilities

The City has also identified opportunities to enhance pedestrian facilities. These are described in the 2017 *SBCTA Safe Routes to School Plan (SRTS)* and in the 2017 *SBCTA Points of Interest Pedestrian Plan (PIPP)*. The *SRTS* focuses on improving access to neighborhood schools listed in Table 5.63, while the *PIPP* focuses on improving access to other community assets listed in Table 5.64. Specific improvement recommendations per project are detailed in the *SRTS Plan Phase II – Volume 2* for items in Table 5.63 and the *PIPP* for items in Table 5.64.

Table 5.63  
SRTS Opportunities

Project	Potential Connection to Bikeways, by Status and Class, within ¼ Mile of Project	Number of Improvements Identified	Cost Estimate
Lankershim E.S.	Existing Class II	10	\$83,698
Warm Springs E.S.	Existing Class II & Planned Class III	10	\$242,614
<b>Total</b>		<b>20</b>	<b>\$326,312</b>

Table 5.64  
PIPP Opportunities

Project	Potential Connection to Bikeways, by Status and Class, within ¼ Mile of Project	Proposed Project Ranking
Highland City Administration & Baseline Rd. Retail	Existing Class II & Planned Class II	1
Highland California Historic District	Planned Class II	2
The Village at East Highlands Shopping, Recreational Facilities & Arroyo Verde Elementary	Existing Class I, II & Planned Class II	3
Highland Library, YMCA, Ball Fields & Cypress Elementary	Existing Class II & Planned Class I	4
Aurantia Park	Existing Class II	NR <sup>A</sup>
Cram Elementary School	Existing Class I, II	NR <sup>A</sup>
Cunningham Neighborhood Park	Existing Class II & Planned Class III	NR <sup>A</sup>
Highland Grove Elementary & Beattle Middle School	Existing Class II & Planned Class I, II	NR <sup>A</sup>

TABLE NOTES – <sup>A</sup>: NR = “Not Ranked”, listed as potential project locations and not included in above map.

### Municipal Code

The City of Highland has not adopted Municipal Code requirements specific to non-motorized transportation or the placement of non-motorized transportation facilities. However, the City adopted a Transportation Control Measures ordinance (Chapter 16.40, Section 16.40.470). That Ordinance commits the City to participate in the implementation of the countywide bicycle plan.

The City's 2006 General Plan Chapter 3, Circulation Element includes Policy 3.7.4, which states “that local bicycle routes will complement regional systems and be compatible with routes of neighboring municipalities”. The NMTP is also consistent with the City’s General Plan, Circulation Element “Figure 3.5, Bikeways”.

### End of Trip Facilities

The City of Highland has bike racks dispersed throughout the City, typically at retail centers, schools, parks, public facilities, and multi-unit housing complexes.

**Multimodal Connectivity**

Table 5.65

Location of Multi-Modal Connections

Facility	Facility Type	Facility Location
SB International Airport	Airport	5 <sup>th</sup> Street.
City-wide Bus Stops	Bus Stops	Throughout City
St. Adelaide Church PNR	Park and Ride Lot	27457 E. Base Line

**Collisions Involving Bicyclists**

Table 5.66

Data for Collisions Involving Bicyclists

Parameter	Collision Rate
Total # of Bicycle Collisions from 2012-2016	25
Total # of Bicycle Fatalities from 2012-2016	0
Total # of Bicycle Injuries from 2012-2016	23
Average # of Bicycle Collisions Per Year	5
Average Bicycle Collision Rate per 1000/year <sup>1</sup>	0.09

Notes:

1. Rate is calculated using SWITRS collision data and population figures by the California Department of Finance

**Safety and Education Programs**

In 2011, City of Highland began to implement a Safe Routes to School Program including bicycle safety and education programs in all eight public elementary schools that serve the residents in Highland.

## City of Loma Linda

### Population

23,476

### City Overview

The City of Loma Linda is located within western San Bernardino County approximately 60 miles east of the City of Los Angeles, California. The City was incorporated in 1970. Jurisdictions that border the City of Loma Linda include: the Cities of Redlands and San Bernardino to the north; the City of Redlands and unincorporated San Bernardino County to the east; unincorporated Riverside and San Bernardino Counties to the south; and unincorporated San Bernardino County and the Cities of Colton and San Bernardino to the west.

Today, Loma Linda is a unique community with strong ties to its religious, educational and healing arts roots. The Loma Linda University Medical Center (LLUMC) and the Jerry L. Pettis Memorial Veterans Medical Center (VA Medical Center) are both internationally known. The City is also home to Loma Linda University, which, with the VA Medical Center and LLUMC, provides much of the economic base of the community.

### Land Use

Loma Linda's land use pattern focuses commercial uses in the northern portion of the City near I-10. Institutional uses are to be located in proximity to such existing uses, such as Loma Linda University (LLU) and Loma Linda Academy. Areas designated for health care uses are also located near to existing similar uses such as Loma Linda University Medical Center (LLUMC), the Jerry L. Pettis VA Medical Center, and the Community Medical Center. Areas for business park exist both at the northern and eastern edges of the community, while industrial uses are located in the eastern portion of the community. Residential uses characterize the central portion of the City (roughly south of Redlands Boulevard), the base of the South Hills, and the flatter areas within the hillsides. A number of mixed-use areas, especially in the eastern portion of the community, allow for a variety of different types of uses (e.g., commercial, office, institutional, and/or residential) to be located next to each other or within the same building.

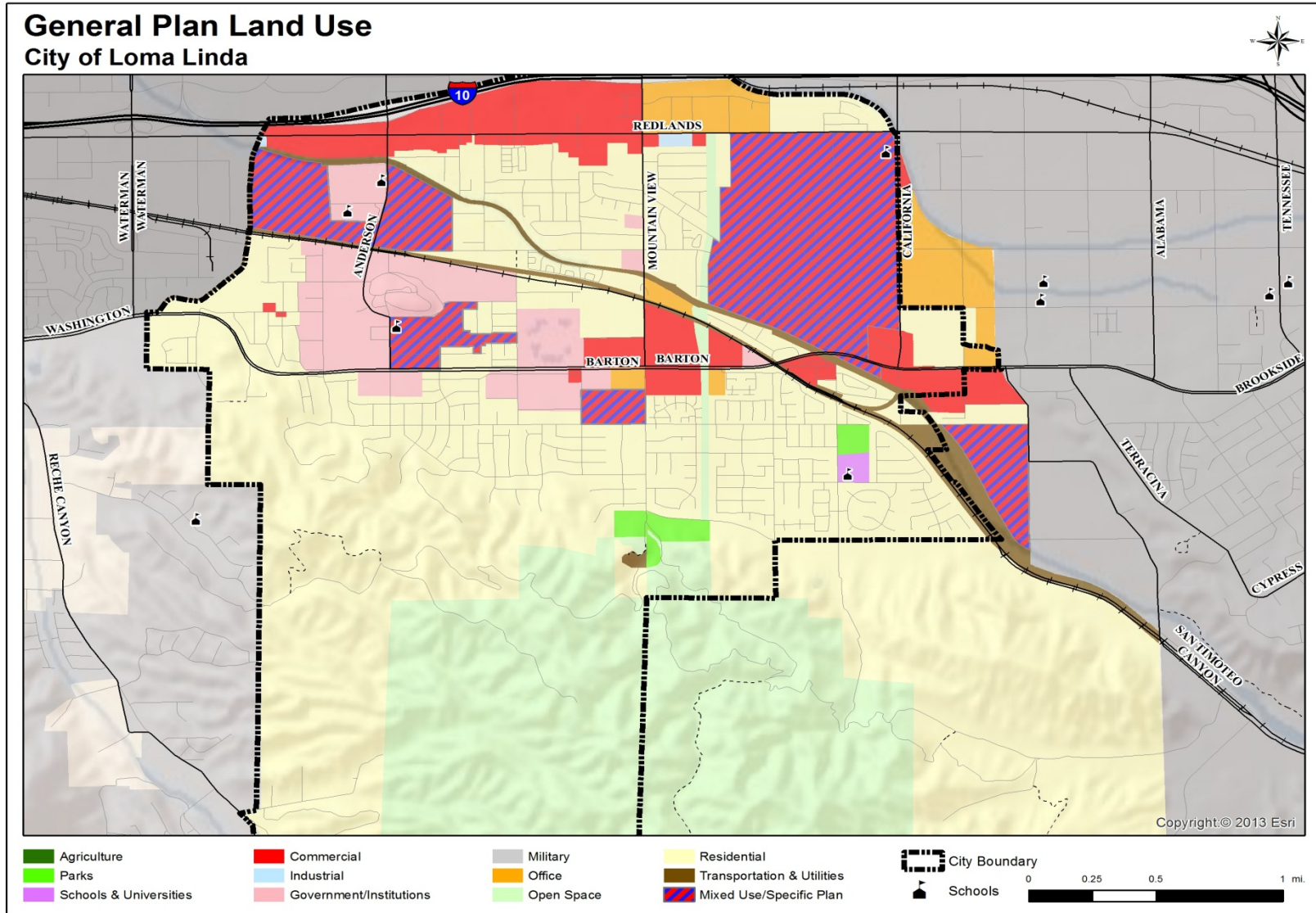

Figure 5.23



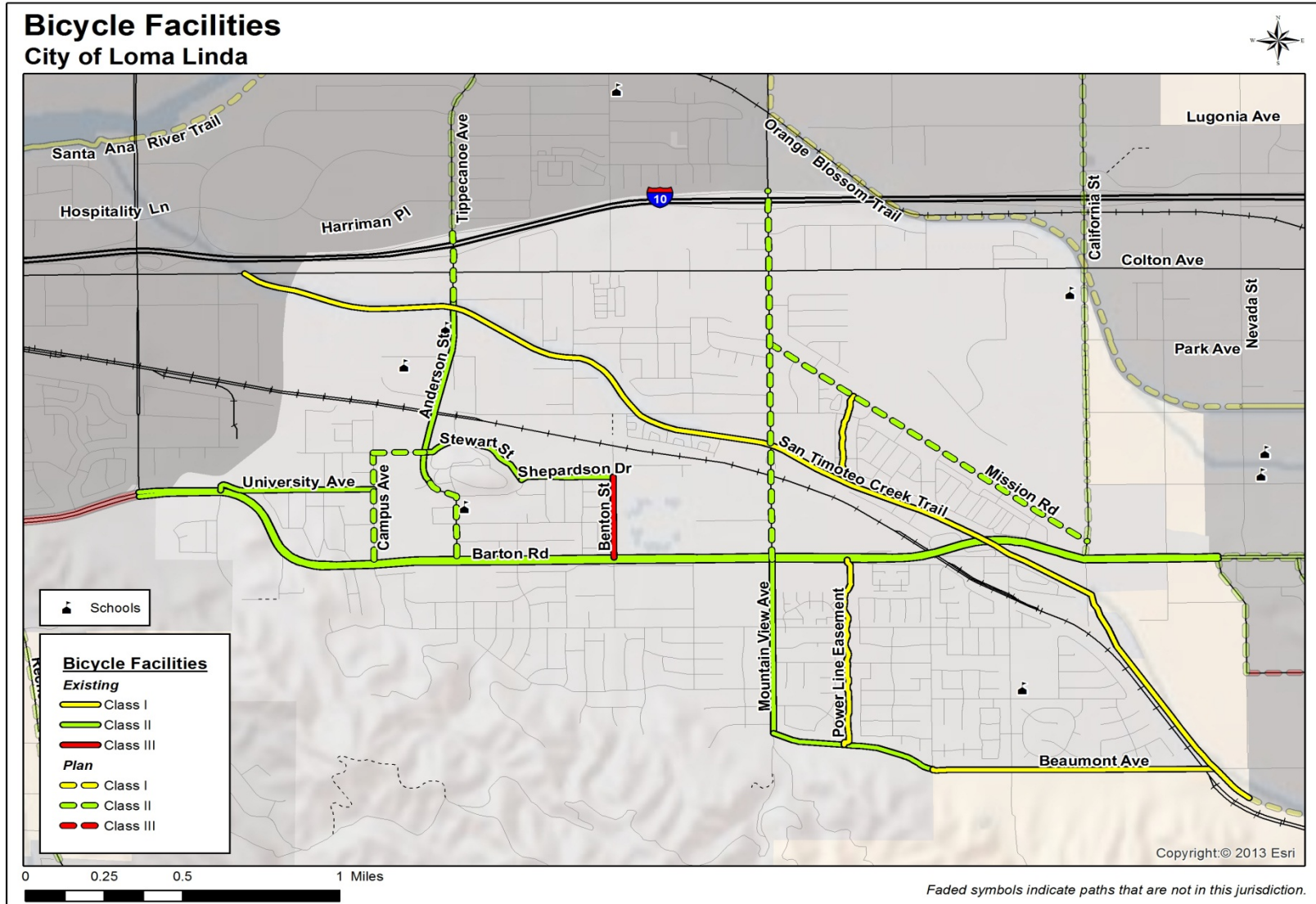

Figure 5.24

**Existing Conditions:**

Loma Linda’s existing non-motorized bicycle network is composed of Class I, Class II and Class III facilities. The main emphasis of the system is on Barton Road, which connects to the City of Colton to the west and the City of Redlands to the east.

Table 5.67

Loma Linda Existing Conditions

Street/Path	From	To	Class	Length (mi.)	Cost Estimate
Anderson St.	Court St.	University Ave.	II	0.66	\$33,000
Barton Rd.	Waterman Ave.	San Timoteo Canyon Rd.	II	7.15	\$357,500
Beaumont Ave.	Bryn Mawr Ave.	Power Line Easement	I	0.92	\$920,000
Beaumont Ave.	Mt View Ave.	Bryn Mawr Ave.	II	0.53	\$26,500
Benton St.	Shepardson St.	Barton Rd.	III	0.28	\$14,000
Mt View Ave.	Barton Rd.	Beaumont Ave.	II	0.61	\$30,500
Power Line Easement	Mission Rd.	San Timoteo Crk. Trail	I	0.31	\$310,000
Power Line Easement	Newport Ave.	Beaumont Ave.	I	0.68	\$680,000
San Timoteo Creek Trail	Redlands Blvd.	Beaumont Ave.	I	3.74	\$3,740,000
Shepardson Dr.	Stewart St.	Benton St.	II	0.29	\$14,500
Stewart St.	Anderson St.	Shepardson Dr.	II	0.38	\$19,000
University Ave.	Barton Rd.	Campus St.	II	0.51	\$25,500
			<b>Total</b>	<b>16.06</b>	<b>\$6,170,500</b>

*Growth/Past investment in system*

Since the San Bernardino County Non-Motorized Transportation Plan was first prepared in 2001, the City of Loma Linda has constructed 5.65 miles of Class I, 10.13 miles of Class II and 0.28 miles of Class III facilities at a rate of 1.06 miles per year.

*Past Investment in Non-Motorized Infrastructure*

The improvements included in Table 5.67 above constitute a significant investment into the non-motorized transportation infrastructure of Loma Linda. Based on planning level estimates, the value of the improvements implemented throughout the City is \$6,170,500.

**Proposed Improvements**

The City of Loma Linda has not identified any proposed future non-motorized improvements.

Table 5.68

Loma Linda Future Improvements

Street/Path	From	To	Class	Length (mi.)	Cost Estimate
Anderson St.	University Ct.	Barton Rd.	II	0.31	\$15,500
Campus Ave.	Steward St.	Barton Rd.	II	0.38	\$18,999
Mission Rd.	Mountain Ave.	California St.	II	1.22	\$61,000
Mountain View Ave.	I-10	San Timoteo Creek Trail	II	0.89	\$44,499
Stewart St.	Campus Ave.	Anderson St.	II	0.16	\$7,999
Tippecanoe Ave.	San Timoteo Creek Trail	I-10/N City Limit	II	0.23	\$11,500
			<b>Total</b>	<b>3.19</b>	<b>\$159,497</b>

**Municipal Code**

The City of Loma Linda has not adopted Municipal Code specific to non-motorized transportation or the placement of non-motorized transportation facilities.

**End of Trip Facilities**

The City of Loma Linda has bike racks dispersed throughout the City, typically at retail centers, schools, multi-unit housing complexes, library and City Hall.

**Multimodal Connectivity**

Table 5.69

Location of Multi-Modal Connections

Facility	Facility Type	Facility Location
City-wide Bus Stops	Bus Stops	Throughout City

**Collisions Involving Bicyclists**

Table 5.70

Data for Collisions Involving Bicyclists

Parameter	Collision Rate
Total # of Bicycle Collisions from 2007-2011	19
Total # of Bicycle Fatalities from 2007-2011	0
Total # of Injuries from 2007-2011	15
Average # of Bicycle Collisions Per Year	3.8
Average Bicycle Collision Rate per 1000/year <sup>1</sup>	0.17

Notes:

1. Rate is calculated using SWITRS collision data and population figures by the California Department of Finance

**Safety and Education Programs**

The City of Loma Linda does not participate in safety or education programs specific to non-motorized transportation or the placement of non-motorized transportation facilities. Citizens can bring any safety concerns to the Loma Linda Traffic Advisory Committee (TAC).

## City of Montclair

### Population

37,311

### City Overview

The City of Montclair was originally incorporated as the City of Monte Vista on April 25, 1956. As part of an effort to create its own identity, the City wanted to have its own Post Office. However, because an unincorporated community with a Post Office already existed in Northern California by that name, the U.S. Postal Service would not open another office unless the newly created city changed its name. On April 8, 1958, the voters of the City of Monte Vista chose to change the city's name to the City of Montclair. The City is comprised of 5.4 square miles of incorporated area and 1.1 square miles of unincorporated sphere of influence.

Montclair is bordered by Pomona to the west, Claremont and Upland to the north, Ontario to the east and unincorporated San Bernardino County (near Chino) to the south

### Land Use

The City of Montclair is largely built out. I-10 bisects the City and most of the land use adjacent to the freeway is commercial or retail oriented. Housing tends to be single-family detached dwelling units located to the south of I-10.

Most of the remaining developable land is located in the northwestern part of the City and covered by the North Montclair Downtown Specific Plan. The proposed land use plan will create new opportunities for a transit-oriented, mixed-use development with a downtown district atmosphere between the Montclair Transcenter (currently a stop on Metrolink's San Bernardino line and eventually a stop on the proposed Metro Gold Line light rail) and the Montclair Plaza regional shopping center.

### Existing Conditions:

Montclair's existing non-motorized bicycle network includes a significant portion of Mills Ave. and its segment of the Pacific Electric Trail. The City constructed a Class II bike path along Mills Ave. from Moreno St. to Holt Blvd. The City also has a portion of the Class I Pacific Electric Trail along its northern boundary that extends from the LA County Line on the west to the City of Fontana on the east.

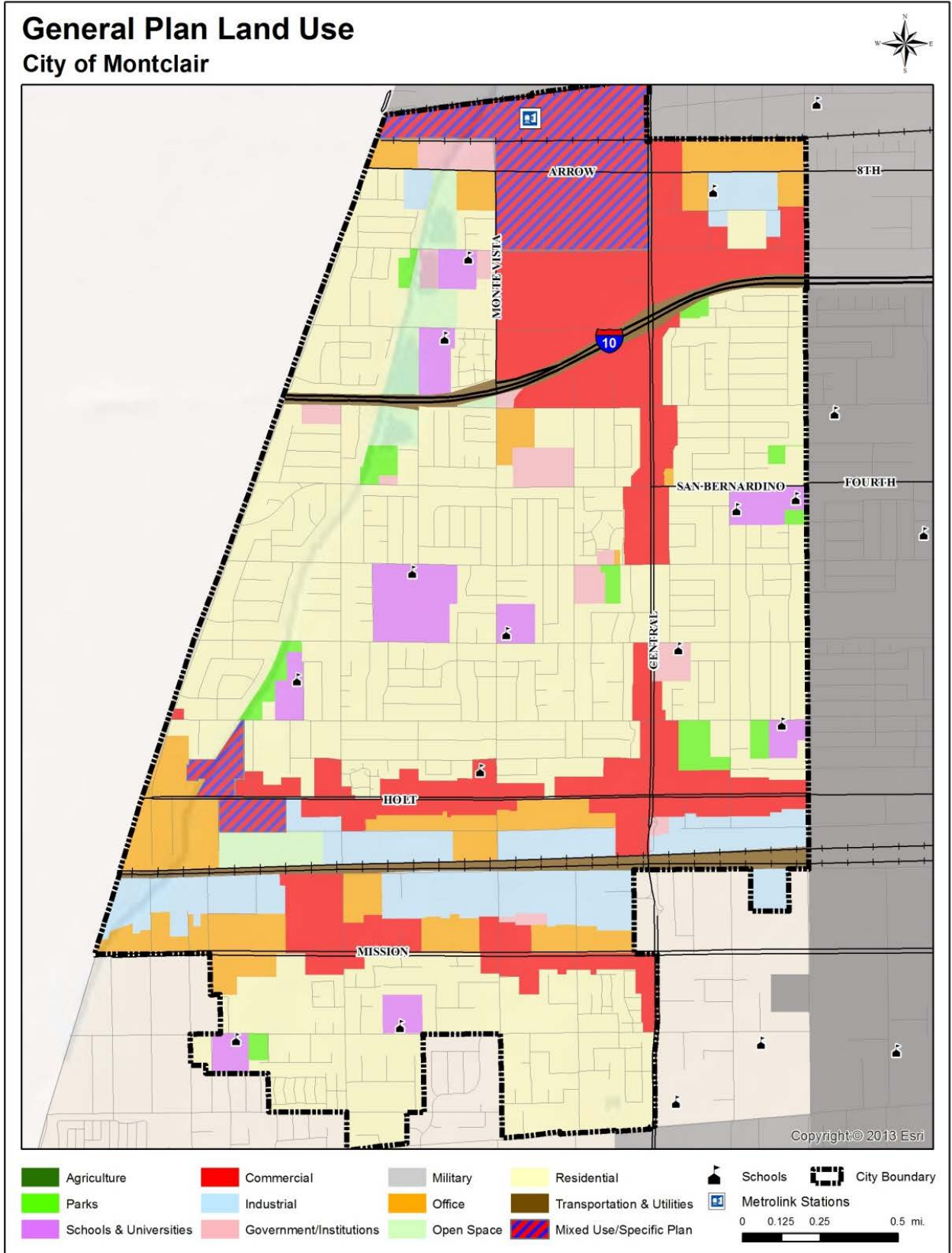

Figure 5.25



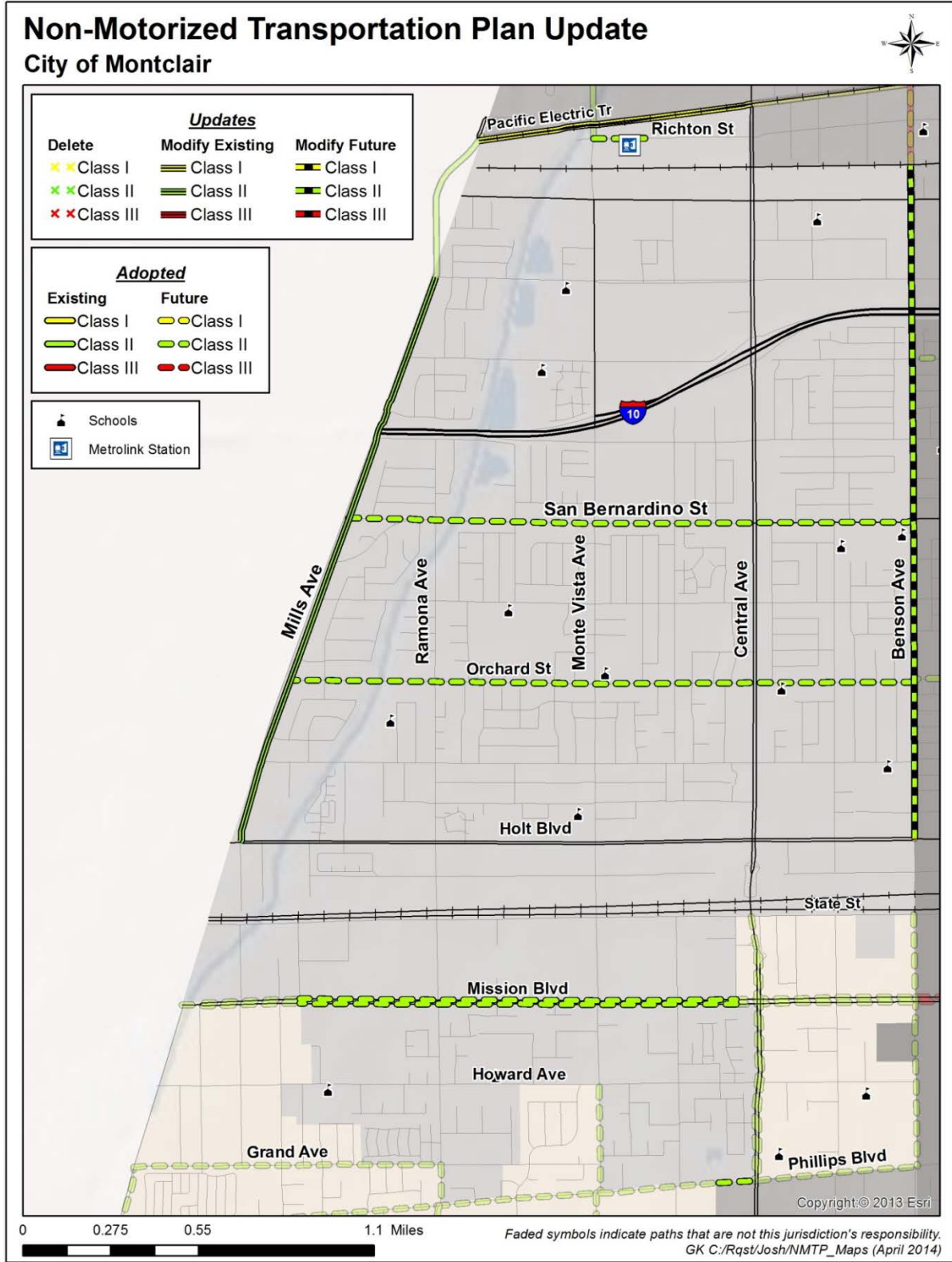
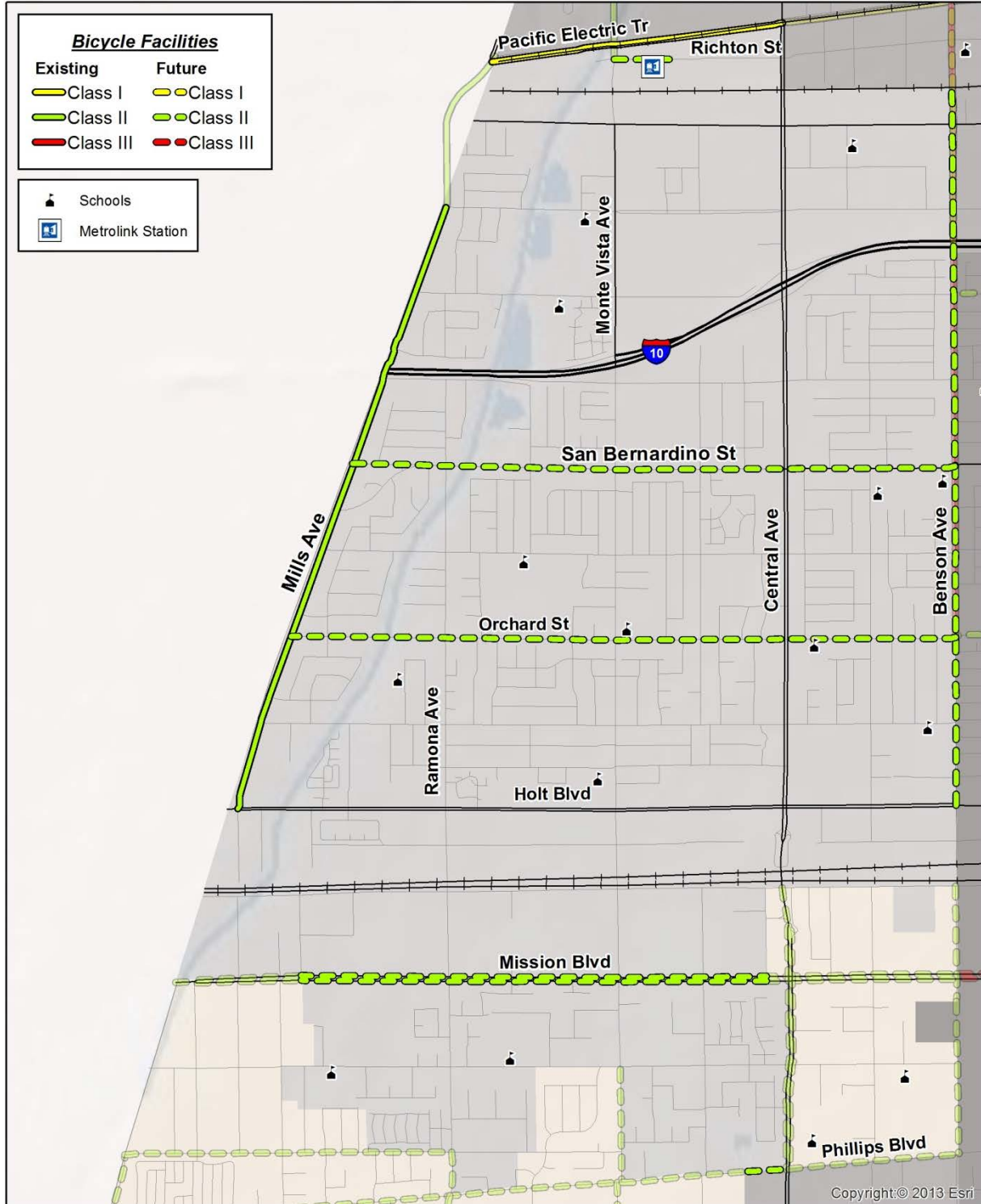

Figure 5.26

# Bicycle Facilities City of Montclair



Faded symbols indicate paths that are not this jurisdiction's responsibility.  
GK C:/Rqst/Josh/NMTP\_Maps (April 2014)

Table 5.71

Montclair Existing Conditions

Street/Path	From	To	Class	Length (mi.)	Cost Estimate
Mills Ave.	Moreno St.	Holt Blvd.	II	1.87	\$94,000
Pacific Electric Trail	LA County Line	Central Ave.	I	0.86	\$860,000
			<b>Total</b>	<b>2.73</b>	<b>\$954,000</b>

*Past Investment in Non-Motorized Infrastructure*

The improvements included in Table 5.71 above constitute a significant investment into the non-motorized transportation infrastructure of Montclair. Based on planning level estimates, the value of the improvements implemented throughout the City is \$954,000.

**Proposed Improvements**

The City of Montclair proposed several additions to its future non-motorized improvements plan in 2013.

Table 5.72

Montclair Future Improvements

Street/Path	From	To	Class	Length (mi.)	Cost Estimate
Benson Ave.	Metrolink/SCRRRA R-O-W	Hold Blvd.	II	2.10	\$105,400
Mission Blvd.	Silicon Ave.	Ada Ave.	II	1.36	\$68,000
Orchard St.	Mills Ave.	Benson Ave.	II	1.95	\$98,000
Phillips Blvd.	0.13mi west of Central Ave	Central Ave.	II	0.12	\$6,000
Richton St.	Monte Vista Ave.	Metrolink Station	II	0.18	\$9,000
San Bernardino St.	Mills Ave.	Benson Ave.	II	1.77	\$89,000
			<b>Total</b>	<b>7.48</b>	<b>\$375,400</b>

Table 5.73

Priority Improvements

Street/Path	From	To	Class	Length (mi.)	Cost Estimate
n/a	n/a	n/a	n/a	n/a	n/a
			<b>Total</b>	<b>n/a</b>	<b>n/a</b>

**Municipal Code**

Montclair Municipal Code 11.66.020 - General provisions for trip reduction – provides the following requirements related to non-motorized transportation and non-motorized transportation infrastructure:

- A. Intent. The purpose of this section is to promote the use of alternative methods of transportation besides use of the single-occupant vehicle. These alternative methods are to be provided in new development so as to meet congestion management and air quality goals at minimal cost and disruption to citizens, business and industry.
- B. Applicability. Prior to issuance of a building permit for any new construction project for which a site plan is submitted on or after January 1, 1994, provisions shall be made for all applicable trip reduction requirements of this section to be implemented. The requirements shall not be applied to existing development, except when new square footage is added.
- C. Trip Reduction Measures. The following trip reduction measures shall be implemented:
  - 1. Nonresidential Projects.
    - a. A bicycle rack or other secure bicycle parking facility shall be provided for every 30 parking spaces within a project and at least one bicycle rack capable of holding three bicycles shall be provided for all projects. Safe and convenient access thereto shall be provided from the public streets.
    - b. On-site pedestrian walkways and bicycle facilities shall be provided connecting each building in a development to the public streets.
    - c. A passenger loading area in a location close to the main building entrance shall be provided for projects with 100 or more parking spaces. The area devoted to loading and unloading of passengers shall be equivalent to a minimum of five parking spaces.
    - d. A minimum of one shower facility accessible to both men and women shall be provided for persons bicycling or walking to work for each project which meets the following thresholds:

Use	Threshold
Commercial	250,000 SF
Office	125,000 SF
Hotels/Motels	250 Rooms
Industrial	325,000 SF

2. Residential Projects.

- a. For multiple dwelling and condominium developments containing 10 or more units:
  - i. A bicycle rack or other secure bicycle parking facility shall be provided for every 30 parking spaces. Each project is to include at least one bicycle rack capable of holding three bicycles.
  - ii. Sidewalks shall be provided from the public streets to each building within the complex.

**End of Trip Facilities**

The City of Montclair has bike racks dispersed throughout the City, typically at retail centers, schools and multi-unit housing complexes.

**Multimodal Connectivity**

Table 5.74

Location of Multi-Modal Connections

Facility	Facility Type	Facility Location
Montclair Transcenter/Metrolink Station	Train Station/Bus Intermodal Center	Richton Street
City-wide Bus Stops	Bus Stops	Throughout City

**Collisions Involving Bicyclists**

Table 5.75

Data for Collisions Involving Bicyclists

Parameter	Collision Rate
Total # of Bicycle Collisions from 2005-2009	77
Total # of Bicycle Fatalities from 2005-2009	2
Average # of Bicycle Collisions Per Year	15.4
Average Bicycle Collision Rate per 1000/year <sup>1</sup>	0.43

Notes:

1. Rate is calculated using SWITRS collision data and population figures by the California Department of Finance

### **Safety and Education Programs**

The City of Montclair does not currently participate in any bicycle safety or education programs.



## City of Needles

### **Population**

5,177

### **City Overview**

The City of Needles is located on the Colorado River at the borders of California, Arizona and Nevada. The City was founded in 1883 with the coming of the Santa Fe Railroad and the City officially incorporated on October 30, 1913. The City is the eastern-most city in San Bernardino County and received its name from the Needles Mountain range, located east of the City.

### **Land Use**

The geographic area of Needles covers approximately 30 square miles with an average population density of 198 people per square mile. Population for the City has remained fairly constant over the past 100 years. Most of the development within Needles is clustered around Interstate 40, Arizona 95, Needles Highway and Broadway Street.

There are a number of recreational opportunities including water-related sports on the Colorado Rivers, hiking the mountain ranges and wilderness areas, and bicycling through the tri-state area. The City of Needles is also home to the Palo Verde Community College and a municipally owned golf course.

### **Existing Conditions:**

There are currently no bicycle facilities in the City of Needles. The City's aging population relies heavily on the use of motorized wheelchairs, travelling side streets to get to the one grocery store in town and other supporting businesses.

### *Growth/Past investment in system*

Since the San Bernardino County Non-Motorized Transportation Plan was first prepared in 2001, the City of Needles has not constructed any bicycle infrastructure improvements within the City. The existing circulation system is comprised of narrow streets, many without sidewalks, making it difficult to widen streets for non-motorized transportation.

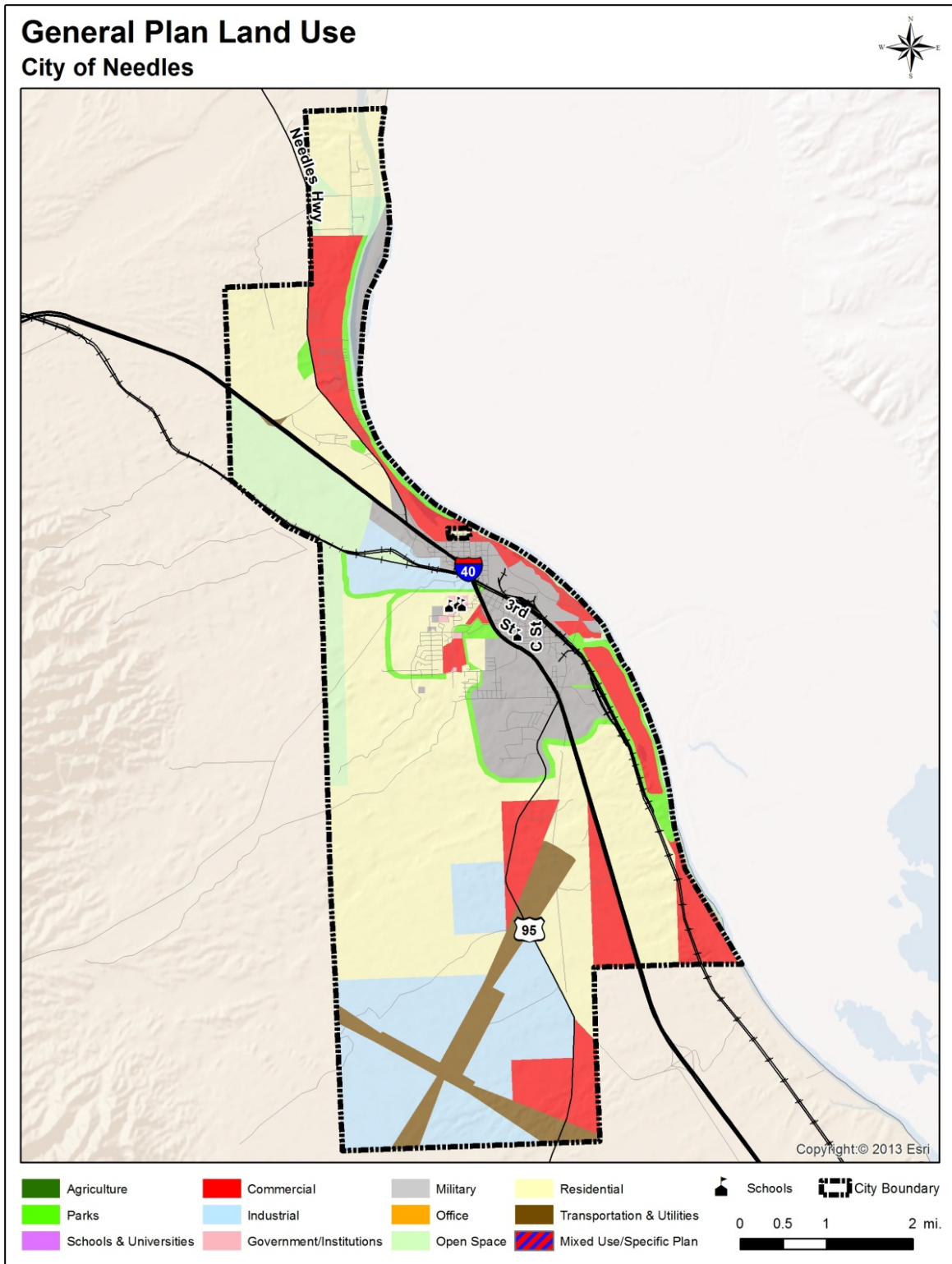
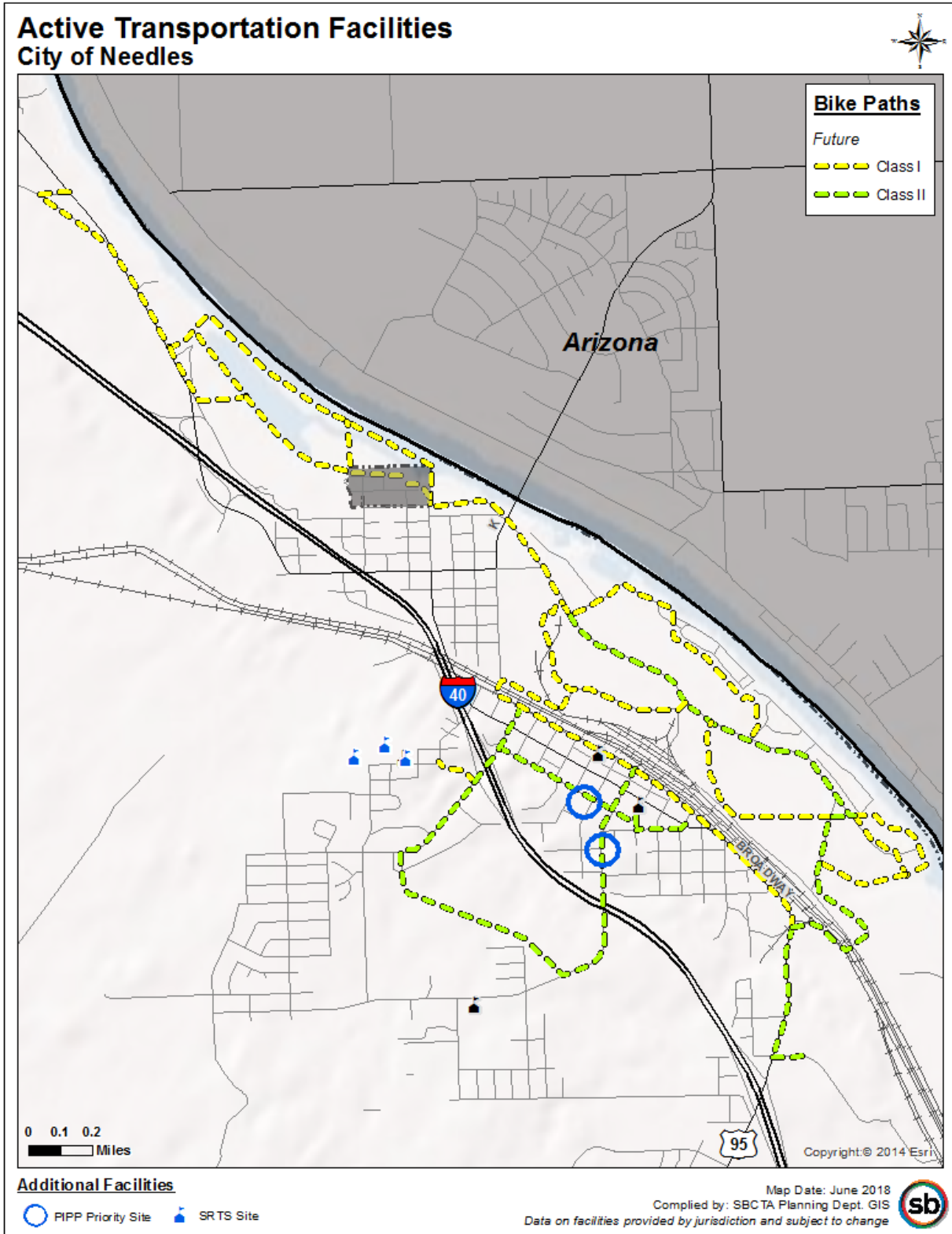

Figure 5.27



C:\Users\christopher\Documents\Projects\BikePlan\_Feb16\start\DataDrivenMaps\ATP\_Portrait.mxd

Figure 5.28

Table 5.76

Needles Existing Conditions

Street/Path	From	To	Class	Length (mi.)	Cost Estimate
n/a	n/a	n/a	n/a	n/a	n/a
			<b>Total</b>	<b>n/a</b>	<b>n/a</b>

**Proposed Improvements**

Table 5.77

Needles Future Improvements

Street/Path	From	To	Class	Length (mi.)	Cost Estimate
3 <sup>rd</sup> St.	J St.	C St.	II	0.48	\$24,000
A St.	Acoma St.	W Broadway Ave.	II	0.01	\$500
Acoma St.	C St.	A St.	II	0.13	\$6,500
Back 9 Golf Course Trail	Park Dr.	River Rd.	I	0.62	\$620,000
Bureau Bay Connector Trail	Jack Smith parking, south corner	Park Dr.	I	0.28	\$280,000
C St.	3 <sup>rd</sup> St.	Acoma St.	II	0.03	\$1,500
E Broadway Ave.	Smith Rd.	Ice Plant Rd.	II	0.42	\$21,000
Ice Plant Rd.	E Broadway Ave.	Needles Towne Center	II	0.10	\$5,000
Jack Smith Trail (Loop)	River Rd.	River Rd.	I	0.64	\$640,000
Lagoon Trail	SE point of 'Switch Yard Trail'	Ross Pkwy	I	0.41	\$410,000
MACAV Trail	0.15mi N/O Ross Pkwy	144'N/O Smokestack Ave & N St.	I	0.44	\$440,000
River Golf Trail (East)	0.10mi SE/O Needles Hwy on River Rd.	Fairway Dr.	I	0.98	\$980,000
River Golf Trail (West)	River Rd.	0.10mi SE/O Needles Hwy on River Rd.	I	0.73	\$730,000
River Rd. Trail	Marina Dr.	River St.	II	0.47	\$23,500
River Rd. Trail 2	River St.	Jack Smith Park, NW corner	II	0.66	\$33,000

Street/Path	From	To	Class	Length (mi.)	Cost Estimate
RR El Garces Bike/Walk Trail	Southerly point of 'River Golf Trail (West)'	Smith Rd.	I	1.53	\$1,530,000
RR Trellis Trail	E Broadway Ave.	Jack Smith Park, NW corner	II	0.79	\$39,500
Switch Yard	115'NW/O Parcel <sup>A</sup> along Needles Hwy	0.10mi NE from 'From' point of this trail	I	0.60	\$600,000
Trail (Loop)	Front St. & J St.	Front St. & D St.	II	2.04	\$102,000
Trail	Needles Hwy at Wayside Rest Stop, SE corner	0.10mi SE/O Needles Hwy on River Rd.	I	2.45	\$2,450,000
Trail	Washington St.	J St.	I	0.14	\$140,000
			<b>Total</b>	<b>13.95</b>	<b>\$9,076,500</b>

TABLE Notes - <sup>A</sup>: Parcel listed on file with SBCTA and is utilized for geographic reference only

The City of Needles has identified two sets of connected bikeways that have mostly Class II facilities. The Trellis – Downtown Walk and Bike Trail stretches from the Golf Course Trail through downtown to the Jack Smith Trail, while the Downtown Shopping Bike / Wheelchair Lane runs further south to a major retail destination.

### Pedestrian Facilities

The City has also identified opportunities to enhance pedestrian facilities. These are described in the 2017 *SBCTA Safe Routes to School Plan (SRTS)* and in the 2017 *SBCTA Points of Interest Pedestrian Plan (PIPP)*. The *SRTS* focuses on improving access to neighborhood schools listed in Table 5.78, while the *PIPP* focuses on improving access to other community assets listed in Table 5.79. Specific improvement recommendations per project are detailed in the *SRTS Plan Phase II – Volume 2* for items in Table 5.78 and the *PIPP* for items in Table 5.79.

Table 5.78  
SRTS Opportunities

Project	Potential Connection to Bikeways, by Status and Class, within ¼ Mile of Project	Number of Improvements Identified	Cost Estimate
Needles H.S.	Planned Class I, II	10	\$215,714
Needles M.S.	None	10	\$215,714
Vista Colorado E.S.	Planned Class I	9	\$215,714
<b>Total</b>		<b>29</b>	<b>\$647,142</b>

Table 5.79  
PIPP Opportunities

Project	Potential Connection to Bikeways, by Status and Class, within ¼ Mile of Project	Proposed Project Ranking
Historic Route 66 Strip Retail, City Hall, & Amtrak Station	Planned Class I, II	1
Katie Hohstadt Elementary	Planned Class II	2
Jack Smith Memorial Park or Ed Parry Park	Planned Class I, II	NR <sup>A</sup>
Needles Recreation Area & Civic Facilities	Planned Class I, II	NR <sup>A</sup>

TABLE NOTES – <sup>A</sup>: NR = “Not Ranked”, listed as potential project locations and not included in above map.

### Municipal Code

The City of Needles is currently reviewing its Municipal Code, as well as its General Plan to incorporate proposed projects such as the San Bernardino County Non-Motorized Transportation Plan into the documents. Currently, the General Plan does not include a circulation element. When funding is available to move forward with revised Municipal Code and a General Plan update, the City intends to revisit the projects listed in this plan.

### End of Trip Facilities

The City of Needles has bike racks dispersed throughout the City, typically at retail centers, schools and multi-unit housing complexes.

### Multimodal Connectivity

Table 5.80

Location of Multi-Modal Connections

Facility	Facility Type	Facility Location
City-wide Bus Stops	Bus Stops	Throughout City



**Collisions Involving Bicyclists**

Table 5.81

Data for Collisions Involving Bicyclists

Parameter	Collision Rate
Total # of Bicycle Collisions from 2012-2016	1
Total # of Bicycle Fatalities from 2012-2016	0
Total # of Bicycle Injuries from 2012-2016	1
Average # of Bicycle Collisions Per Year	0.2
Average Bicycle Collision Rate per 1000/year <sup>1</sup>	0.04

Notes:

1. Rate is calculated using SWITRS collision data and population figures by the California Department of Finance

**Safety and Education Programs**

The City of Needles does not participate in safety or education programs specific to non-motorized transportation or the placement of non-motorized transportation facilities. However, the City does participate in a more general McGruff safety program, which teaches children to alert municipal employees for assistance when they see the “McGruff” sticker on a utility truck.

## City of Ontario

### Population

177,589

### City Overview

Ontario incorporated as a city in 1891 and now includes 50 square miles of area. Ontario was founded in September of 1882 by George and William B. Chaffey. The city was named after the home of the Chaffey brothers, Ontario, Canada. Ontario had been declared The “Model Colony” as an Act of the Congress of the United States in 1903 for its character and history reflected in its cultural, historical, and architectural heritage. The Model Colony set a new standard for rural communities and remained the classic pattern for irrigation projects for many years.

The City of Ontario is located approximately 35 miles east of downtown Los Angeles, 20 miles west of the City San Bernardino, and 30 miles northwest of central Orange County. Ontario is widely viewed as Southern California’s next urban center and is considered the inland region’s population and job growth center.

Ontario is strategically located within a regional transportation network that includes an international airport with passenger and air cargo operations, three freeways, three freight rail lines, commuter and passenger rail services, public transit and a local network of streets and multi-purpose trails. This network provides multi-modal transportation options for those traveling within, to or through the City. This robust system creates unique opportunities for Ontario as a regional jobs hub and a complete community.

### Land Use

The Land Use Element of the General Plan provides for uses and development that add value to the community, in terms of function, design and fiscal return. This element guides and regulates land use patterns, densities, and intensities in Ontario.

Subsequently, the mobility system will be coordinated with future land use patterns and levels of build out. Access and connectivity to mobility options will be integrated into neighborhoods, villages and districts. The placement of housing, jobs and amenities in closer proximity to each other and design strategies focused on the pedestrian will make walking a desirable alternative and a connected regional system of multi-purpose trails (including bikeways) will enable safe and convenient non-motorized travel.

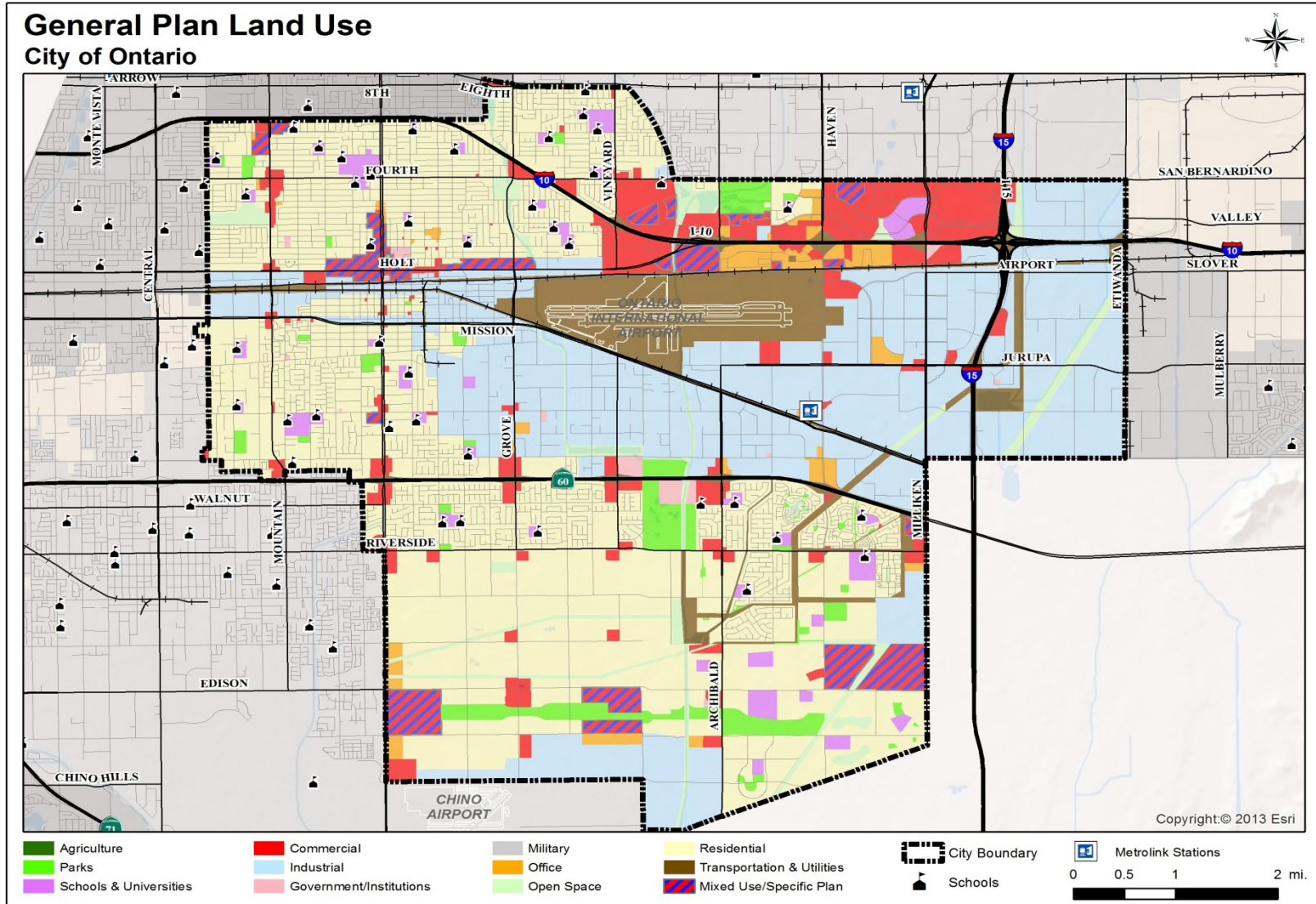

Figure 5.29

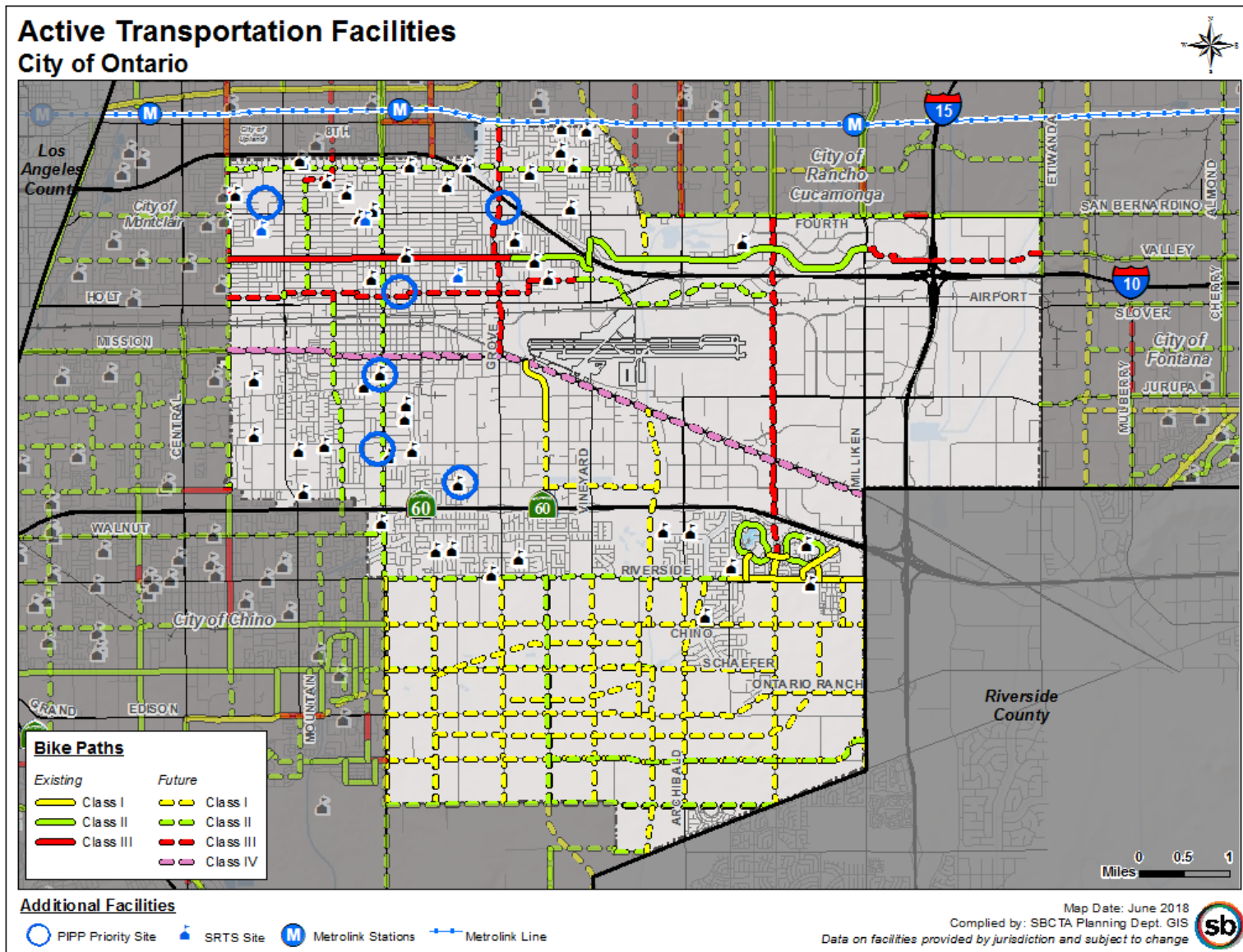

Figure 5.30  
5-121

**Existing Conditions:**

Class I and II bike lanes currently exist within the Creekside East and Creekside West master planned community which is located just south of the SR 60 Freeway on the east and west sides of Haven Avenue. Class II bike lanes exist on Lytle Creek Loop and Deer Creek Loop roads within the communities. These lanes connect to a Class I bike path on the north side of Riverside Drive between Turner and Milliken Avenues. Class II and III bike lanes/routes exist on G Street and Inland Empire Boulevard to provide an east-west connection through central Ontario from Benson Avenue to Milliken Avenue. As developments occur, Class II and III bike lanes/routes and Recreational Trails are being constructed in Ontario Ranch to provide multimodal opportunities with this new development.

Table 5.82

Ontario Existing Conditions

Street/Path	From	To	Class	Length (mi.)	Cost Estimate
Deer Creek Loop	Creekside Dr.	Creekside Dr.	II	1.22	\$61,000
Haven Ave.	Creekside Dr.	Riverside Dr.	I	0.24	\$240,000
Lytle Creek Loop	Creekside Dr.	Creekside Dr.	II	1.17	\$58,500
Riverside Dr.	Turner Ave.	SCE ROW	I	1.31	\$1,310,000
Riverside Dr.	SCE ROW	Hamner Ave.	I	0.24	\$240,000
W Cucamonga Creek Channel	Mission Blvd.	Locust St.	I	0.73	\$730,000
G St.	Benson Ave.	Del Norte Ave.	III	3.12	\$46,800
G St.	Del Norte Ave.	Vineyard Ave.	II	0.95	\$47,500
Vineyard Ave.	G St.	Inland Empire Blvd.	II	0.43	\$21,500
Inland Empire Blvd.	Vineyard Ave.	Milliken Ave.	II	1.19	\$59,500
Creekside	Deer Creek Loop	Lytle Creek Loop	I <sup>A</sup>	0.21	\$210,000
Creekside Trail	Deer Creek Loop	Riverside Dr.	I <sup>A</sup>	0.29	\$290,000
Creekside Trail	McCloud River Way	San Lorenzo River Rd.	I <sup>A</sup>	0.53	\$530,000
Mill Creek Ave.	Lytle Creek Loop	Riverside Dr.	I <sup>A</sup>	0.21	\$210,000
			<b>Total</b>	<b>11.84</b>	<b>\$4,054,800</b>

TABLE NOTES – <sup>A</sup>: Jurisdiction designates this path for local purposes as a “Multipurpose Path”

**Proposed Improvements**

Future improvements to the non-motorized network for the City of Ontario will continue along the major transportation corridors throughout the City. Future improvements focus on development of Class I, Class II, Class III and Class IV facilities. Most future improvements are proposed to be constructed in the New Model Colony, because it is largely currently undeveloped and will require less investment to complete than



reconstructing the infrastructure of the older areas of Ontario. All proposed future improvements are included in Table 5.83.

When complete, the City will have constructed an additional 125.05 miles of Class I, Class II, Class III and Class IV, providing internal connectivity to the residents of Ontario and establishing connections to the non-motorized networks of adjacent cities including, Chino, Fontana, Rancho Cucamonga and Upland. Ontario has identified the priority improvements listed in Table 5.84 below. The facilities are not in any particular order but will be constructed as funds become available, in conjunction with new infill as development occurs and/or as roadways are widened.

Table 5.83

Ontario Future Improvements

Street/Path	From	To	Class	Length (mi.)	Cost Estimate
6 <sup>th</sup> St.	Benson Ave.	Cucamonga Creek Channel	II	4.44	\$222,400
Archibald Ave.	Riverside Dr.	Merrill Ave.	I <sup>A</sup>	2.78	\$2,780,000
.B St.	Vine Ave.	Sultana Ave.	III <sup>B</sup>	0.57	\$8,550
Benson Ave.	0.18 mi. N. Howard St.	0.06mi. N. Howard St.	II	0.12	\$6,000
Benson Ave.	G St.	s/o Brooks St.	III	0.49	\$7,400
Benson Ave.	I-10 Freeway	G St.	III	1.15	\$17,250
Campus Ave. (ROW Imprv.)	Riverside Dr.	Merrill Ave.	I	2.49	\$2,490,000
Campus Ave. (Street Imprv.)	Riverside Dr.	Merrill Ave.	II	2.49	\$124,500
Carpenter St.	N. Remington Ave.	S. Remington Ave.	II	0.04	\$2,000
Chino Ave.	Euclid Ave.	Hamner Ave.	I <sup>A</sup>	5.30	\$5,300,000
Convention Center Way	Vineyard Ave.	Holt Blvd	II	0.46	\$23,000
Cucamonga Creek Channel	4 <sup>th</sup> St.	Inland Empire Blvd.	I	0.47	\$470,000
Cucamonga Creek Channel	Mission Blvd.	South City Limit	I	4.92	\$4,920,000
D St.	Imperial Ave.	Corona Ave.	III <sup>B</sup>	0.54	\$8,100
D St.	Corona Ave.	Vineyard Ave.	II	0.14	\$7,000
Edison Ave./Ontario Ranch Rd.	Euclid Ave.	Hamner Ave.	I <sup>A</sup>	5.29	\$5,290,000
Eucalyptus Ave. (ROW Imprv.)	Euclid Ave.	Hamner Ave.	I <sup>A</sup>	5.40	\$5,400,000
Eucalyptus Ave. (Street Imprv.)	Walker Ave.	Hamner Ave.	II	3.62	\$181,000
Euclid Ave.	I-10 Freeway	Riverside Dr.	II	4.69	\$234,500
Euclid Ave.	Riverside Dr.	Merrill Ave.	I <sup>A</sup>	2.57	\$2,570,000
Great Park	Campus Ave.	Mill Creek	I <sup>A</sup>	3.03	\$3,030,000
Grove Ave.	8 <sup>th</sup> St.	Mission Blvd.	III	3.16	\$47,400
Grove Ave.	Riverside Dr.	Merrill Ave.	I <sup>A</sup>	2.50	\$2,500,000



Street/Path	From	To	Class	Length (mi.)	Cost Estimate
Guasti Rd.	Holt Blvd.	Haven Ave.	II	1.80	\$27,000
Haven Ave.	4 <sup>th</sup> St.	Creekside Dr.	III	6.70	\$100,500
Haven Ave.	Riverside Dr.	Merrill Ave.	I <sup>A</sup>	2.50	\$2,500,000
Hawthorne St.	San Antonio Ave.	Boulder Ave.	III <sup>B</sup>	0.31	\$4,650
Imperial Ave.	Nocta St.	D St.	III <sup>B</sup>	0.12	\$1,800
Ontario Mills Pkwy	Milliken Ave.	Etiwanda Ave.	III	2.61	\$39,150
Lower Deer Creek Channel	Riverside Dr.	Archibald Ave.	I	0.81	\$810,000
Merrill Ave. (ROW Imprv.)	Euclid Ave.	Haven Ave.	I <sup>A</sup>	4.30	\$4,300,000
Merrill Ave. (Street Imprv.)	Euclid Ave.	Haven Ave.	II	4.30	\$215,000
Mill Creek Ave.	Chino Ave.	Ontario Ranch Rd.	I <sup>A</sup>	1.00	\$1,000,000
Milliken Ave.	Mission Blvd.	Bellegrove Ave.	I	2.09	\$2,100,000
Mission Blvd.	Benson Ave.	Bon View Ave.	IV <sup>C</sup>	2.54	\$6,635,490
Mission Blvd.	Bon View Ave.	Milliken Ave.	IV <sup>C</sup>	4.80	\$12,539,509
Mountain Ave.	Stoneridge St.	Vesta St.	II	0.04	\$2,000
Nocta St.	Sultana Ave.	Imperial Ave.	III <sup>B</sup>	1.33	\$66,500
Hellman Ave.	Chino Ave.	Ontario Ranch Rd.	I <sup>A</sup>	1.01	\$1,010,000
Philadelphia St.	W Cucamonga Creek Channel	Cucamonga Creek Channel	I	1.22	\$1,220,000
Remington Ave.	Carpenter St.	Cucamonga Creek Channel	II	0.35	\$17,500
Riverside Dr.	Euclid Ave.	Hamner Ave.	II	5.50	\$275,000
San Antonio Ave.	I-10 Freeway	Hawthorne St.	II	0.26	\$13,000
San Antonio Ave.	Vesta St.	Holt Blvd	III	0.13	\$6,500
San Antonio Ave.	Holt Blvd.	Mission Blvd.	II	0.54	\$27,000
San Antonio Ave.	Mission Blvd.	Southern City Limits	II	1.63	\$81,500
Stoneridge St.	Benson Ave.	Mountain Ave.	III <sup>B</sup>	0.62	\$9,300
SCE ROW	Cucamonga Creek Channel	Campus Ave.	I	3.20	\$3,200,000
SCE ROW	Grove Ave.	Hellman Ave	I	1.65	\$1,650,000
SCE ROW	Riverside Dr.	Chino Ave.	I	0.49	\$490,000

Street/Path	From	To	Class	Length (mi.)	Cost Estimate
Schaefer Ave.	Euclid Ave.	Cucamonga Creek Channel	II	2.94	\$147,000
Schaefer Ave.	Euclid Ave.	Haven Ave.	I <sup>A</sup>	4.29	\$4,290,000
Vesta St.	Mountain Ave.	Vine Ave.	III <sup>B</sup>	0.81	\$12,150
Vine Ave.	Vesta St.	B St.	III <sup>B</sup>	0.04	\$600
Vineyard Ave.	Riverside Dr.	Merrill Ave.	I <sup>A</sup>	2.50	\$2,500,000
W. Cucamonga Creek Channel	Mission Blvd.	Philadelphia St.	I	0.74	\$740,000
Walker Ave. (ROW Imprv.)	Riverside Dr.	Merrill Ave.	I <sup>A</sup>	2.51	\$2,510,000
Walker Ave. (Street Imprv.)	Riverside Dr.	Merrill Ave.	II	2.51	\$125,500
Walnut St.	Fern Ave.	Euclid Ave.	II	0.20	\$10,000
			<b>Total</b>	<b>125.05</b>	<b>\$84,315,749</b>

TABLE NOTES – <sup>A</sup>: Jurisdiction designates this path for local purposes as a “Multipurpose Path”;

– <sup>B</sup>: Jurisdiction designates this path for local purposes as a “Sharrows”;

– <sup>C</sup>: Cost per mile of \$2,612,397.64 pulled from jurisdiction estimates

Table 5.84

Priority Improvements

Street/Path	From	To	Class	Length (mi.)	Cost Estimate
Cucamonga Creek Channel	4th St.	Inland Empire Blvd.	I	0.47	\$470,000
Cucamonga Creek Channel	Mission Blvd.	South City Limit	I	4.92	\$4,920,000
Euclid Ave.	I-10 Freeway	Riverside Dr.	II	4.69	\$234,500
Euclid Ave.	Riverside Dr.	Merrill Ave.	I <sup>A</sup>	2.57	\$2,570,000
Grove Ave.	8 <sup>th</sup> St.	Mission Blvd.	III	3.17	\$47,400
Haven Ave.	Riverside Dr.	Merrill Ave.	I	2.50	\$2,500,000
Inland Empire Blvd.	Haven Ave.	Etiwanda Ave.	III	4.93	\$73,950
Inland Empire Blvd.	Vineyard Ave.	Haven Ave.	II	2.63	\$131,500
Mission Blvd.	Benson Ave.	Bon View Ave.	IV <sup>C</sup>	2.54	\$6,635,490
Mission Blvd.	Bon View Ave.	Milliken Ave.	IV <sup>C</sup>	4.80	\$12,539,509

Street/Path	From	To	Class	Length (mi.)	Cost Estimate
Ontario Mills Pkwy	Milliken Ave.	Etiwanda Ave.	III	2.61	\$39,150
Philadelphia St.	W Cucamonga Creek Channel	Cucamonga Creek Channel	I	1.22	\$1,220,000
San Antonio Ave.	I-10 Freeway	Hawthorne St.	II	0.26	\$13,000
San Antonio Ave.	Holt Blvd.	Mission Blvd.	II	0.54	\$27,000
San Antonio Ave.	Mission Blvd.	Southern City Limits	II	1.63	\$81,500
Vesta St.	Boulder Ave.	San Antonio Ave.	II	0.27	\$13,500
W. Cucamonga Creek Channel	Mission Blvd.	Philadelphia St.	I	0.74	\$740,000
			<b>Total</b>	<b>40.49</b>	<b>\$32,256,499</b>

TABLE NOTES – <sup>A</sup>: Jurisdiction designates this path for local purposes as a “Multipurpose Path”;

– <sup>B</sup>: Jurisdiction designates this path for local purposes as a “Sharrow”;

– <sup>C</sup>: Cost per mile of \$2,612,397.64 pulled from jurisdiction estimates

### Pedestrian Facilities

The City has also identified opportunities to enhance pedestrian facilities. These are described in the 2017 *SBCTA Safe Routes to School Plan (SRTS)* and in the 2017 *SBCTA Points of Interest Pedestrian Plan (PIPP)*. The *SRTS* focuses on improving access to neighborhood schools listed in Table 5.85, while the *PIPP* focuses on improving access to other community assets listed in Table 5.86. Specific improvement recommendations per project are detailed in the *SRTS Plan Phase II – Volume 2* for items in Table 5.85 and the *PIPP* for items in Table 5.86.

Table 5.85  
SRTS Opportunities

Project	Potential Connection to Bikeways, by Status and Class, within ¼ Mile of Project	Number of Improvements Identified	Cost Estimate
Elderberry E.S.	None	11	\$168,740
Lincoln E.S.	Existing Class III & Planned Class III	9	\$77,929
Vina Danks M.S.	Planned Class II	5	\$857,034
	<b>Total</b>	<b>35</b>	<b>\$1,103,703</b>

Table 5.86  
PIPP Opportunities

Project	Potential Connection to Bikeways, by Status and Class, within ¼ Mile of Project	Proposed Project Ranking
Ontario Town Square & Galvin Park Shopping Center	Planned Class II, III	1
John Galvin Park & Galvin Park Shopping Center	Planned Class III	2
Anthony Munoz Hall of Fame, Colony Park Community & Elderberry High	None	3
De Anza Park & Euclid Elementary	Planned Class II, IV	4
Bon View Elementary and Park	None	5
Ontario Christian School & Ontario Plaza Shopping Center	Planned Class II	6
Chaffey High School	Planned Class II	NR <sup>A</sup>
Colony High School	Existing Class I & Planned Class II	NR <sup>A</sup>
Cucamonga-Guasti Regional Park	Existing Class II & Planned Class II	NR <sup>A</sup>
D Street Park/James Galanis Park	Existing Class II, III & Planned Class III	NR <sup>A</sup>
Kimball Park, Ontario Centennial Park, Woodcrest Jr. High School & Liberty Elementary School	Planned Class I, II	NR <sup>A</sup>
Ontario Amtrak Station	Planned Class II, III	NR <sup>A</sup>
Westwind Park	Planned Class I, II	NR <sup>A</sup>

TABLE NOTES – <sup>A</sup>: NR = “Not Ranked”, listed as potential project locations and not included in above map.

### Municipal Code

Ontario Development Code Sec. 6.03.035 - Bicycle Parking– provides the following:

Bicycle parking facilities, including bicycle racks, lockers and other secure facilities shall be provided in conjunction with development projects pursuant to current regulations contained in CALGreen (CAC Title 24, Part 11).

### End of Trip Facilities

The City of Ontario has bike racks dispersed throughout the City, typically at retail centers, schools and multi-unit housing complexes.

**Multimodal Connectivity**

Table 5.87

Location of Multi-Modal Connections

Facility	Facility Type	Facility Location
East Ontario Metrolink Station	Train Station	3330 E. Francis St.
Ontario TransCenter	Bus Transfer Station	Sultana/Holt
Ontario Mills TransCenter	Bus Transfer Station	Ontario Mills Outlet Mall
Ontario Airport TransCenter	Bus Transfer Station	Airport Drive
City-wide Bus Stops	Bus Stops	Throughout City
Montecito Church PNR	Park and Ride Lot	2560 S. Archibald Ave.

**Collisions Involving Bicyclists**

Table 5.88

Data for Collisions Involving Bicyclists

Parameter	Collision Rate
Total # of Bicycle Collisions from 2012-2016	229
Total # of Bicycle Fatalities from 2012-2016	5
Total # of Bicycle Injuries from 2012-2016	224
Average # of Bicycle Collisions Per Year	45.8
Average Bicycle Collision Rate per 1000/year <sup>1</sup>	0.26

Notes:

1. Rate is calculated using SWITRS collision data and population figures by the California Department of Finance

**Safety and Education Programs**

The City of Ontario has conducted several bicycle safety and education programs, including two bike rodeos targeted to young bicycle riders.

## City of Rancho Cucamonga

### Population

171,058

### City Overview

Located at the base of the San Gabriel foothills, with majestic views of Cucamonga and Ontario peaks, Rancho Cucamonga is like no other community in the Inland Empire. Rancho Cucamonga's spirit of heritage stems from its history as a collection of three small communities: Cucamonga, Alta Loma, and Etiwanda. The area thrived on the agricultural fruits of citrus and grapes. This history is celebrated today through public art, evocative architecture, and well-preserved historic places. Historic Route 66 (Foothill Boulevard) traces across town, contributing to the nostalgia of the well-known and romanticized highway that still resonates with residents today.

### Land Use

The map in Figure 5.31 shows the current and future land use patterns in the City of Rancho Cucamonga. In the past the City has maintained a focus on developing a sustainable balance of residential, commercial and industrial development. Now that the City is nearing built-out, the City is focusing its efforts on the best use for remaining infill properties and guiding the redevelopment of aging commercial and industrial properties.

### Existing Conditions:

Rancho Cucamonga boasts a robust system of bikeways, including numerous Class I, II and III facilities. Portions of four Class I corridors—the Pacific Electric Trail, Cucamonga Creek Channel, and Day Creek Channel—have been constructed for a total of 13.39 miles, transect the city providing a network of right-of-way separated from vehicular traffic and dedicated to non-motorized transportation.

Additionally, 59.25 miles of Class II bike lanes have been striped throughout the City. The bike lanes provide connectivity to the Class I facilities and provide access to commercial, residential, educational and recreational amenities throughout the city.

Finally, 39.5 miles of signed Class III facilities, or bike routes, have been designated throughout Rancho Cucamonga. The current Class III facilities tend to be on either lower volume corridors or corridors that are scheduled to become Class II facilities in the future as pavement and striping is rehabilitated.



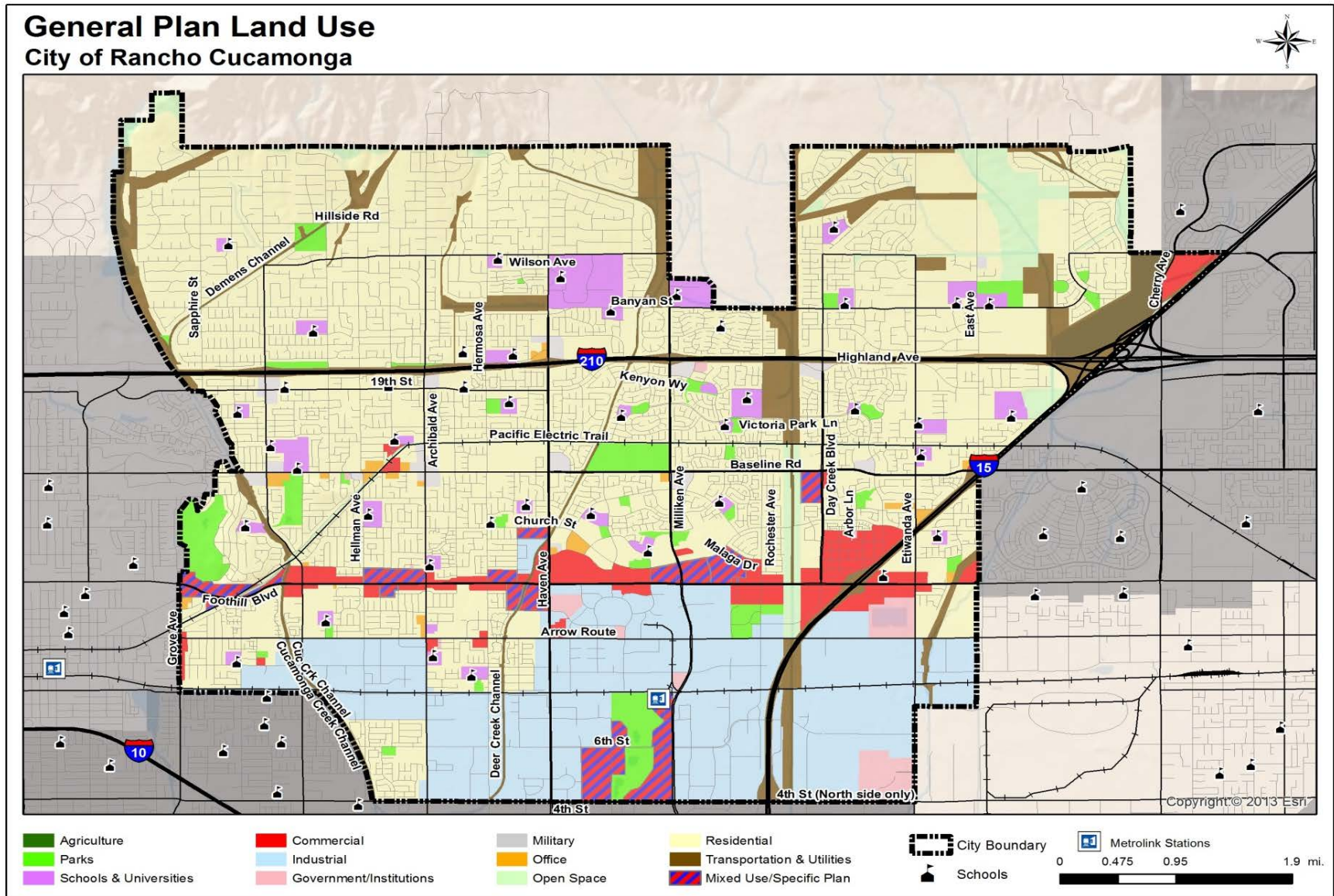

Figure 5.31

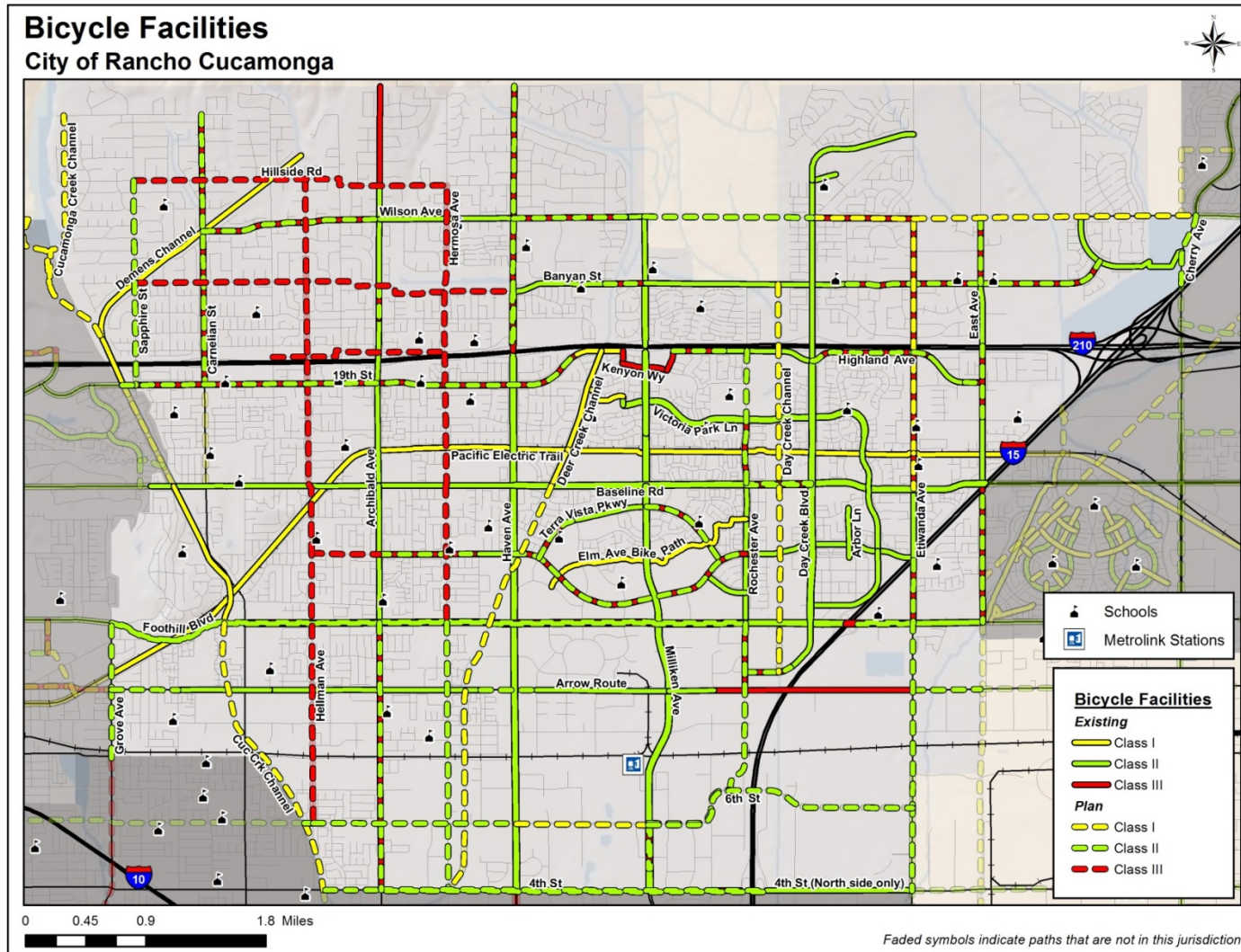

Figure 5.32



Table 5.89

Rancho Cucamonga Existing Conditions

Street/Path	From	To	Class	Length (mi.)	Cost Estimate
19th St.	W City Limit	San Benito Ave.	III	3.49	\$52,350
4th St. (North side only)	Buffalo Ave.	I-15 off ramps	III	0.21	\$3,150
4th St. (North side only)	I-15 off ramps	Etiwanda Ave.	II	1.08	\$54,000
Alberta Pl.	Loyola Ct	Menlo St.	I	0.03	\$30,000
Arbor Ln.	Vinter Dr.	Cultural Center Dr.	II	0.37	\$18,500
Archibald Ave.	Banyan Ave.	Lemon Ave.	III	0.24	\$3,600
Archibald Ave.	Base Line Rd.	Foothill Blvd	II	1.02	\$51,500
Archibald Ave.	Foothill Blvd.	4th St.	III	2.01	\$30,150
Archibald Ave.	Hillside Rd.	Banyan Ave.	II	0.74	\$37,000
Archibald Ave.	Lemon Ave.	Baseline Rd.	II	1.25	\$62,500
Archibald Ave.	N City Limit	Hillside Rd.	III	0.74	\$11,100
Arrow Route	Baker Ave.	Bear Gulch Pl.	II	0.68	\$34,500
Arrow Route	Bear Gulch Pl.	Hellman Ave.	II	0.31	\$16,000
Arrow Route	Hellman Ave.	Center Ave.	II	1.26	\$63,000
Arrow Route	Milliken Ave.	Victory Dr.	II	0.33	\$17,000
Arrow Route	Utica Ave.	Milliken Ave.	II	0.99	\$49,500
Arrow Route	Victory Dr.	Etiwanda Ave.	III	1.49	\$22,350
Banyan St.	Bluegrass Ave.	East Ave.	III	0.99	\$49,500
Banyan St.	East Ave.	Young's Cnyn Rd.	III	0.96	\$14,400
Banyan St.	Fredericksburg Ave.	Milliken Ave.	III	0.30	\$4,500
Banyan St.	Haven Ave.	Fredricksburg Ave.	II	0.70	\$35,000
Banyan St.	Milliken Ave.	Bluegrass Ave.	II	1.51	\$75,500
Baseline Rd.	Day Creek Blvd.	I-15	II	2.63	\$131,500
Baseline Rd.	Rochester Ave.	Day Creek Blvd.	III	0.96	\$14,400
Baseline Rd.	W City Limit	Rochester Ave.	II	6.20	\$310,000
Carnelian St.	Almond St.	19th St.	III	2.02	\$30,300
Charleston St.	Melno St.	Fairmont Way	I	0.23	\$230,000
Church St.	Archibald Ave.	Center St.	III	0.74	\$11,100
Church St.	Center St.	Haven Ave.	II	0.26	\$13,000
Church St.	Haven Ave.	Rochester Ave.	III	1.97	\$29,550
Church St.	Rochester Ave.	Victoria Gardens Ln.	II	1.00	\$50,000
Coyote Dr.	Day Creek Blvd.	Duncaster Pl.	II	0.18	\$9,000
Cucamonga Creek Channel	Base Line Rd.	Foothill Blvd.	I	1.14	\$1,140,000
Cucamonga Creek Channel	Demens Channel	19th St.	I	0.38	\$380,000
Day Creek Blvd.	2000' s/o Foothill Blvd.	Rochester Ave.	III	0.35	\$5,250
Day Creek Blvd.	Coyote Dr.	2000' s/o Foothill Blvd.	II	5.68	\$284,000
Day Creek Blvd.	Etiwanda Ave.	Coyote Dr.	II	0.94	\$47,100
Demens Channel	Cucamonga Creek Channel	n/o Hillside Rd.	I	2.01	\$2,010,000
East Ave.	Banyan Ave.	SR-210	II	0.46	\$23,000

East Ave.	I-15	Foothill Blvd.	III	1.00	\$15,000
East Ave.	SR-210	Victoria St.	III	0.56	\$8,400
East Ave.	Victoria St.	I-15	II	0.46	\$23,000
East Ave.	Wilson Ave.	Banyan St.	III	0.49	\$7,350
Elm Ave. Bike Path	Town Center Dr.	Rochester Ave.	I	1.77	\$1,770,000
Etiwanda Ave.	250' s/o Church St.	Foothill Blvd.	III	0.44	\$6,600
Etiwanda Ave.	Baseline Rd.	250' s/o Church St.	II	0.53	\$26,500
Etiwanda Ave.	Wilson Ave.	Baseline Rd.	III	2.02	\$30,300
Fairmont Way	Charleston St.	Victoria Park Ln.	II	0.06	\$3,000
Fairmont Way	Highland Ave.	Kenyon Way	III	0.09	\$1,350
Foothill Blvd.	Etiwanda Ave.	East Ave.	II	1.04	\$52,000
Foothill Blvd.	I-15	Etiwanda Ave.	III	1.00	\$15,000
Foothill Blvd.	Rochester Ave.	I-15	II	1.5	\$75,000
Foothill Blvd.	Vineyard Ave.	Rochester Ave.	III	7.5	\$112,500
Haven Ave.	N City Limit	SR-210	III	2.39	\$35,850
Haven Ave.	SR-210	4th St.	II	8.04	\$402,000
Highland Ave.	225' e/o DiCarlo Pl.	East Ave.	III	0.13	\$1,950
Highland Ave.	350' w/o Rufino Pl.	Day Creek Blvd.	II	0.74	\$37,000
Highland Ave.	680' e/o Etiwanda Ave.	225' e/o DiCarlo Pl.	II	0.33	\$16,500
Highland Ave.	Day Creek Blvd.	680' e/o Etiwanda Ave.	III	0.90	\$13,500
Highland Ave.	San Benito Ave.	Fairmont Way	I	0.34	\$340,000
Highland Ave.	Woodruff Pl.	350' w/o Rufino Pl.	III	0.31	\$4,650
Kenyon Way	Fairmont Way	Woodruff Pl.	III	0.34	\$5,100
Loyloa Ct.	Deer Creek Channel	Alberta Pl.	I	0.05	\$50,000
Malaga Dr.	Church St.	Rochester Ave.	II	0.32	\$16,000
Miller Ave.	Victoria Gardens Ln.	I-15	II	0.27	\$13,500
Milliken Ave.	450' s/o 5th St.	4th St.	II	0.32	\$16,000
Milliken Ave.	6th St.	450' s/o 5th St.	III	0.68	\$10,200
Milliken Ave.	Arrow Route	6th St.	II	2.04	\$102,000
Milliken Ave.	Baseline Rd.	Arrow Route	II	3.12	\$156,000
Milliken Ave.	Fairmont Way	Baseline Rd.	II	0.76	\$38,000
Milliken Ave.	SR-210	Fairmont Way	II	1.22	\$61,000
Milliken Ave.	Wilson Ave.	SR-210	II	1.39	\$69,500
Pacific Electric Trail	Grove Ave.	I-15	I	7.44	\$7,440,000
Rochester Ave.	Base Line Rd.	Foothill Blvd.	II	1.03	\$51,500
Rochester Ave.	Foothill Blvd.	Arrow Route	III	0.50	\$7,500
Rochester Ave.	Victoria Park Ln.	Base Line Rd.	III	0.47	\$7,050
Terra Vista Pkwy.	Church St.	Spruce Ave.	III	0.41	\$6,150
Terra Vista Pkwy.	Milliken Ave.	Church St.	III	0.73	\$10,950
Terra Vista Pkwy.	Spruce Ave.	Milliken Ave.	II	0.53	\$26,500
Victoria Gardens L	Church St.	Day Creek Blvd.	II	0.81	\$40,500
Victoria Park Ln.	Fairmont Way	Church St.	II	4.90	\$245,000
Wardmand Bullock Rd./Youngs Canyon Rd.	Wilson Ave.	Cherry Ave.	II	1.12	\$56,100
Wilson Ave.	Archibald Ave.	Haven Ave.	II	1.00	\$50,000
Wilson Ave.	Carnelian St.	Archibald Ave.	III	1.33	\$19,950
Wilson Ave.	Day Creek Blvd.	Etiwanda Ave.	III	0.76	\$11,400
Wilson Ave.	High Meadow Pl.	Milliken Ave.	II	0.13	\$6,500
Wilson Ave.	Haven Ave.	High Meadow Pl.	III	0.84	\$12,600

Woodruff Pl.	Highland Ave.	Kenyon Way	III	0.15	\$2,250
			<b>Total</b>	<b>112.15</b>	<b>\$16,982,000</b>

*Past Investment in Non-Motorized Infrastructure*

The improvements included in Table 5.89 above constitute a significant investment into the non-motorized transportation infrastructure of Rancho Cucamonga. Based on planning level estimates, the value of the improvements implemented throughout the City is \$16,982,000.

**Proposed Improvements**

Rancho Cucamonga boasts an extensive network of non-motorized improvements. Future improvements to the non-motorized network continue to build additional connectivity throughout the system. Most future improvements focus on further development of additional Class II facilities, including the upgrade of most existing Class III facilities to Class II standards. However, the City also proposes to construct two additional Class I facilities—along portions of Etiwanda Ave. and Wilson Ave—as well as provide for several new Class III corridors. A table of future improvements is included in Table 5.90 below.

Table 5.90

Rancho Cucamonga Future Improvements

Street/Path	From	To	Class	Length (mi.)	Cost Estimate
19th St.	W City Limit	San Benito Ave.	II	3.59	\$179,500
4th St.	Cucamonga Creek Channel	I-15 off ramps	II	6.19	\$309,500
6th St.	Cucamonga Creek Channel	Hellman Ave	II	0.06	\$3,350
6th St.	Hellman Ave.	Etiwanda Ave.	II	4.69	\$234,500
6th St.	Milliken Ave.	Haven St.	I	.99	\$990,000
Archibald Ave.	Banyan Ave.	Lemon Ave.	II	0.24	\$12,000
Archibald Ave.	Foothill Blvd.	4 <sup>th</sup> St.	II	2.00	\$100,500
Arrow Route	Center Ave.	Utica Ave.	II	0.41	\$21,000
Arrow Route	Etiwanda Ave.	Hickory Ave.	II	0.50	\$25,000
Arrow Route	Grove Ave.	Baker Ave.	II	0.50	\$25,000
Banyan St.	Bluegrass Ave.	East Ave.	II	0.99	\$49,500
Banyan St.	East Ave.	Young's Canyon Rd.	II	0.96	\$48,000
Banyan St.	Fredericksburg Ave.	Milliken Ave.	II	0.30	\$15,000
Banyan St.	Sapphire St.	Haven Ave.	III	2.89	\$43,350
Base Line Rd.	Rochester Ave.	Day Creek Blvd.	II	0.96	\$48,000
Carnelian St.	Almond St.	19th St.	II	2.02	\$101,000

Cherry Ave.	Wilson Ave./Beech Ave.	I-15	II	0.56	\$28,000
Church St.	Archibald Ave.	Center St.	II	0.74	\$37,000
Church St.	Haven Ave.	Rochester Ave.	II	1.97	\$98,500
Church St.	Hellman Ave.	Archibald Ave.	III	0.50	\$7,500
Cucamonga Creek Channel	4th St.	Foothill Blvd.	I	2.21	\$2,210,000
Cucamonga Creek Channel	Demens Channel	Almond St.	I	1.76	\$1,760,000
Day Creek Blvd.	2000' s/o Foothill Blvd.	Rochester Ave.	II	0.35	\$17,500
Day Creek Channel	Banyon St.	Jack Benny Dr.	I	2.90	\$2,900,000
Deer Creek Channel	Baseline Rd.	4th St.	I	3.18	\$3,180,000
East Ave.	I-15	Foothill Blvd.	II	0.94	\$47,000
East Ave.	SR-210	Victoria St.	II	0.53	26,500
East Ave.	Wilson Ave.	Banyon St.	II	0.49	\$24,500
Etiwanda Ave.	250' s/o Church St.	4th St.	II	2.45	\$122,500
Etiwanda Ave.	Wilson Ave.	Baseline Rd.	I	2.02	\$2,020,000
Foothill Blvd.	Grove Ave.	Rochester Ave.	II	9.61	\$480,500
Foothill Blvd.	I-15	Etiwanda Ave.	II	0.80	\$40,000
Grove Ave.	Foothill Blvd.	8th St.	II	1.01	\$50,500
Haven Ave.	N. City Limit	SR-210	II	2.35	\$117,500
Hellman Ave.	Hillside Rd.	6th St.	III	4.83	\$72,450
Hermosa Ave.	Foothill Blvd.	4th St.	II	2.00	\$100,000
Hermosa Ave.	Hillside Rd.	Foothill Blvd.	III	3.27	\$49,050
Highland Ave.	225' e/o DiCarlo Pl.	East Ave.	II	0.13	\$6,500
Highland Ave.	Beryl St.	Hermosa Ave.	III	1.33	\$19,950
Highland Ave.	Day Creek Blvd.	680' e/o Etiwanda Ave.	II	0.77	\$38,500
Highland Ave.	Etiwanda Ave.	680' e/o Etiwanda Ave.	II	0.13	\$6,500
Highland Ave.	Woodruff Pl.	350' w/o Rufino Pl.	II	0.44	\$22,000
Hillside Rd.	Sapphire St.	Hermosa Ave.	III	2.39	\$35,850
Milliken Ave.	6th St.	450' s/o 5th St.	II	0.66	\$33,000
Pacific Electric Connector	Pacific Electric Trail	Day Creek Channel Trail	I	0.25	\$250,000
Pacific Electric Trailhead	Etiwanda Ave.	1,000 feet east	I	0.23	\$230,000
Rochester Ave.	Foothill Blvd.	6th St.	II	1.30	\$65,000
Rochester Ave.	Highland Ave.	Base Line Rd.	II	1.00	\$50,000
Sapphire St.	Hillside Rd.	19th St.	II	1.53	\$76,500
Terra Vista Pkwy.	Church St.	Spruce Ave.	II	0.41	\$20,500
Terra Vista Pkwy.	Milliken Ave.	Church St.	II	0.72	\$36,000
Wilson Ave.	Carnelian St.	Archibald Ave.	II	1.33	\$66,500
Wilson Ave.	Day Creek Blvd.	Cherry Ave.	I	2.87	\$2,870,000
Wilson Ave.	Haven Ave.	High Meadow Pl.	II	0.84	\$42,000
Wilson Ave.	Milliken Ave.	Day Creek Blvd.	II	1.25	\$62,500
			<b>Total</b>	<b>89.34</b>	<b>\$19,525,500</b>

When complete, the City will have constructed an additional 93.58 miles of Class I, II and Class III facilities, providing additional internal connectivity to the residents of Rancho Cucamonga and increased connectivity to communities in the West San Bernardino Valley.



The list of priority improvements for the City of Rancho Cucamonga is located in Table 5.91 below. The priority list includes additional connectivity to and from the Pacific Electric Trail and Day Creek Trail.

Table 5.91

Priority Improvements

Street/Path	From	To	Class	Length (mi.)	Cost Estimate
Day Creek Channel	Pacific Electric Trail	Jack Benny Dr.	I	2.90	\$2,900,000
Deer Creek Channel	Base Line Rd.	4th St.	I	3.18	\$3,180,000
Pacific Electric Connector	Pacific Electric Trail	Day Creek Channel Trail	I	0.25	\$250,000
Pacific Electric Trailhead	Etiwanda Ave.	1,000 feet east	I	0.23	\$230,000
			<b>Total</b>	<b>6.56</b>	<b>\$6,560,000</b>

**Municipal Code**

The City of Rancho Cucamonga municipal code includes the following two provisions governing the provision of non-motorized infrastructure:

*Bicycle Storage:* Bicycle storage spaces shall be provided in all multi-family residential projects of more than 10 units, commercial, office, and industrial districts in accordance with the following:

- Minimum spaces equal to 5 percent of the required automobile parking spaces or 3 bicycle storage spaces, whichever is greater. After the first 50 bicycle storage spaces are provided, additional storage spaces required are 2.5 percent of the required automobile parking spaces.
- Warehouse distribution uses shall provide bicycle storage spaces at a rate of 2.5 percent of the required automobile parking spaces with a minimum of a 3-bike rack.
- In no case shall the total number of bicycle parking spaces required exceed 100. Where this results in a fraction of 0.5 or greater, the number shall be rounded off to the higher whole number.

*Bicycle and Other Two-Wheel Vehicular Facilities.*

For developments with at least 40 total parking spaces, required on-site parking may be reduced at a rate of 1 automobile parking space per 4 spaces of bicycle storage, up to 50 automobile parking spaces or 10 percent of the total required on-site parking, whichever is less, where locker rooms and showers are provided for employees to promote bicycle commuting.

The standard related to Bicycle and other Two-Wheel Vehicular Facilities only applies to Industrial Districts, and is aimed at promoting bicycle commuting where locker rooms and showers are provided.

**End of Trip Facilities**

The City of Rancho Cucamonga has bike lockers at the Rancho Cucamonga Metrolink Station and bike racks dispersed throughout the City.

**Multimodal Connectivity**

The City of Rancho Cucamonga has the following multimodal facilities that interface with the non-motorized transportation system.

Table 5.92

Location of Multi-Modal Connections

Facility	Facility Type	Facility Location
Rancho Cuc. Metrolink Station	Train Station	11208 Azusa Court
City-wide Bus Stops	Bus Stops	Throughout City
Base Line PNR Lot	Ride Share Lot	13231 Baseline Rd.
Highland Ave Church PNR Lot	Ride Share Lot	9944 Highland Ave.

**Collisions Involving Bicyclists**

Table 5.93

Data for Collisions Involving Bicyclists

Parameter	Collision Rate
Total # of Bicycle Collisions from 2005-2009	91
Total # of Bicycle Fatalities from 2005-2009	3
Average # of Bicycle Collisions Per Year	18.2
Average Bicycle Collision Rate per 1000/year <sup>1</sup>	0.11

Notes:

1. Rate is calculated using SWITRS collision data and population figures by the California Department of Finance

**Safety and Education Programs**

The City of Rancho Cucamonga and the San Bernardino County Sherriff hold an annual safety program for children called the Ron Ives Bicycle Rodeo, with a goal to increase bicycle awareness and education among young riders.

## City of Redlands

### **Population**

71,196

### **City Overview**

The City of Redlands was incorporated in November 1888 and comprises an area of approximately 37.5 square miles in the East San Bernardino Valley. The early migration to Redlands as a wintering place for well to do Midwestern and Easterners, created a rich diversity in architecture. The City continues to be a beautiful community, composed of historic Victorian, California Craftsman, Classic Revival, and Mission Revival style homes.

At the heart of the City, and framed by the San Bernardino Mountains, the University of Redlands contains a number of classic buildings and is connected by tree-lined greens. Additionally, the City is home to ESRI Corporation which is a leader in Geographic Information Systems (GIS) technology.

### **Land Use**

The City's General Plan Growth Management Element establishes limitations on future development and land use. This grew out of the first growth management voter initiative; Proposition R, which was first passed by Redlands voters in 1978. Proposition R was later amended by Measure N (a zoning ordinance) in 1987. This policy restricts the development of residential dwelling units to 400 units a year within the city, and the extension of utilities to 150 units per year outside of the existing city limits (within the Sphere of Influence, and therefore in the County of San Bernardino's jurisdiction.

Measure U, adopted by voters in 1997, further articulated growth management policies. This General Plan Amendment reinforced and modified certain provisions of Measure N, adopted Principles of Managed Growth, and reduced the development density of San Timoteo and Live Oak canyons by creating a new land use category: Resource Preservation. Under Measure U, no land designated by the General Plan as Urban Reserve as of June 1, 1987, is to be re-designated for a higher density than RE designation unless specified findings are made by a four-fifths vote of the City Council.

### **Existing Conditions:**

There are several segments on non-contiguous portions of the Orange Blossom Trail totaling 4.26 miles constructed.

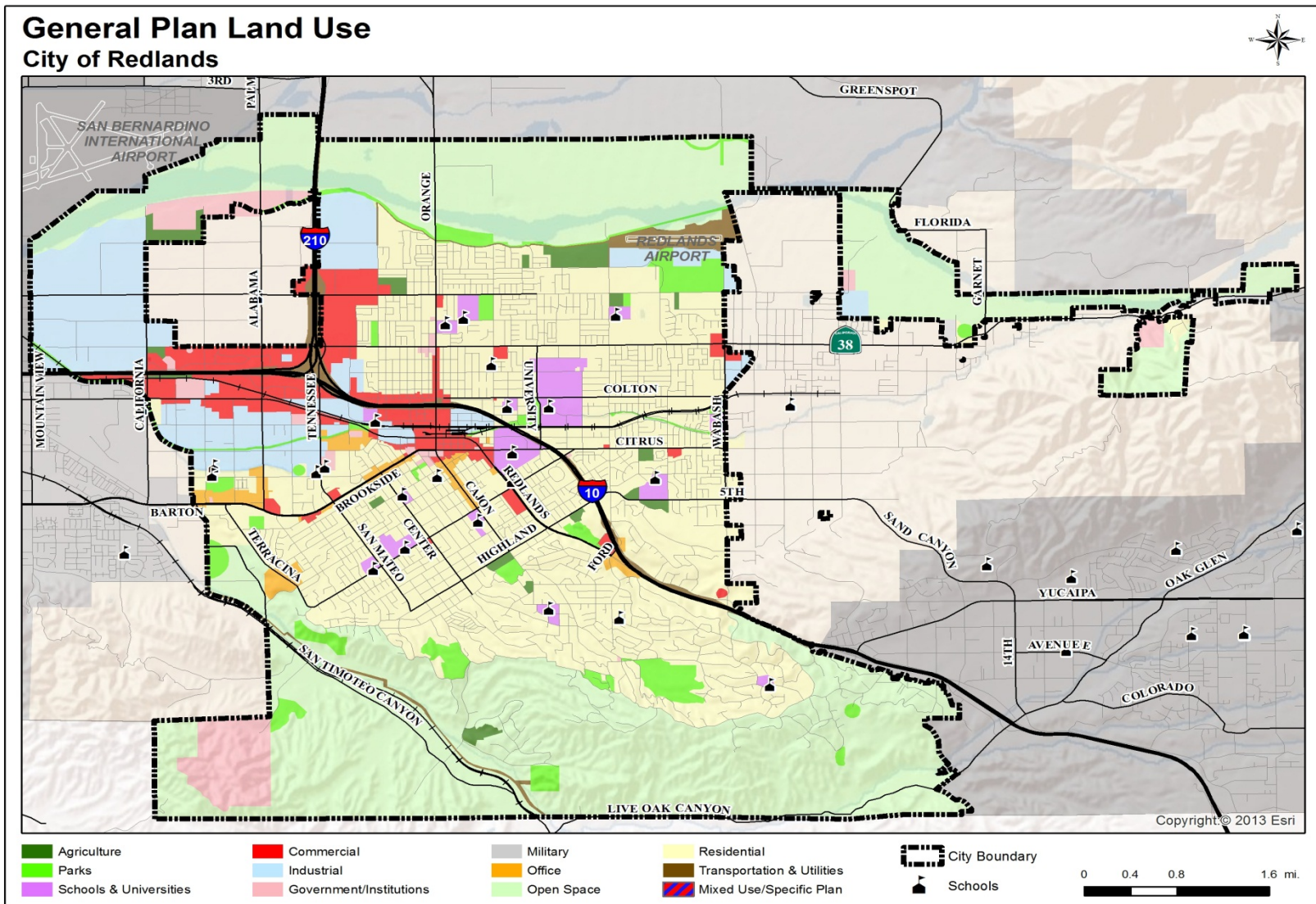

Figure 5.33



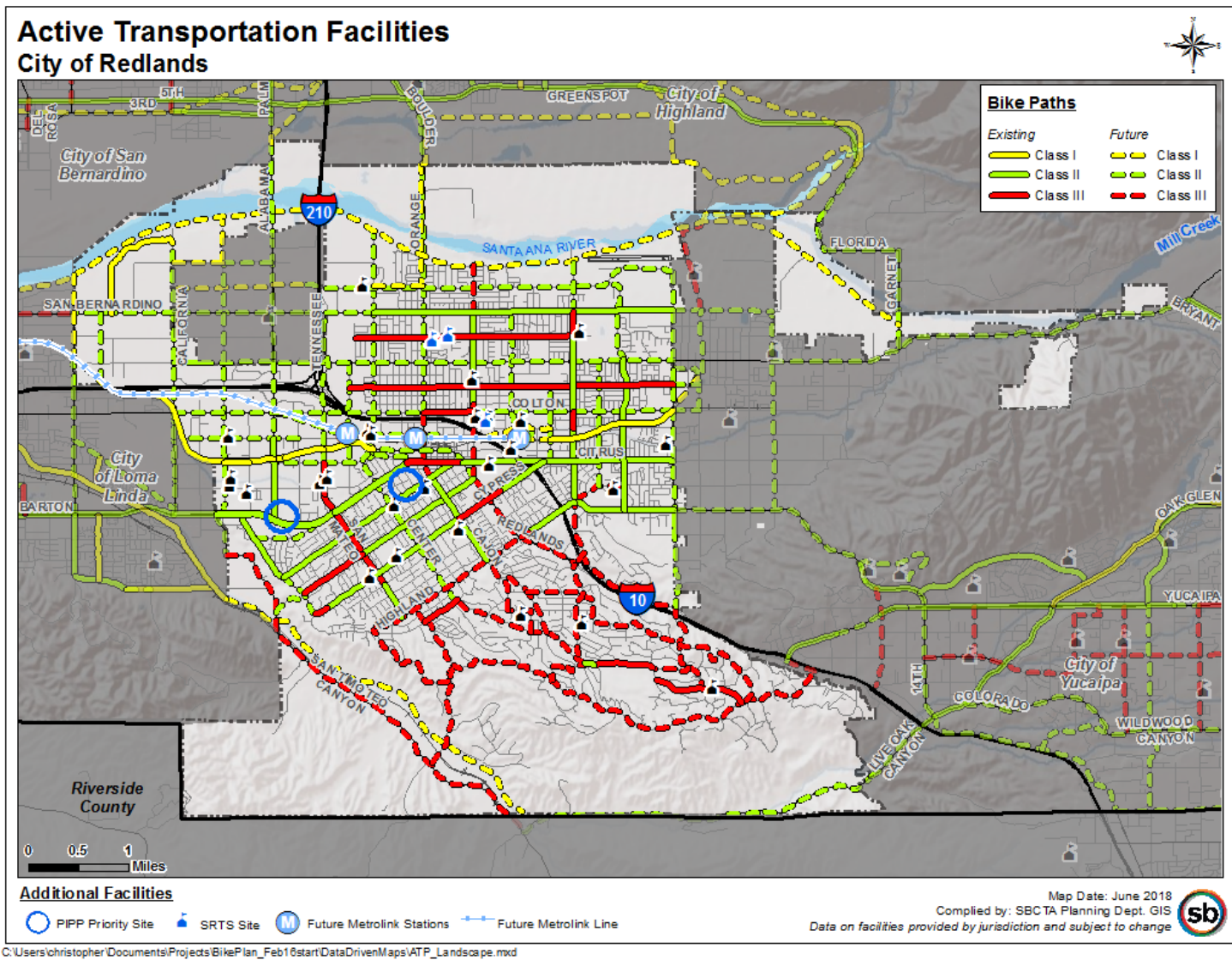

Figure 5.34

Table 5.94

Redlands Existing Conditions

Street/Path	From	To	Class	Length (mi.)	Cost Estimate
5th Ave.	Ford St.	Wabash Ave.	II	1.01	\$51,000
Alabama St.	Barton Rd.	Park Ave.	II	0.82	\$41,000
Barton Rd.	San Timoteo Canyon Rd.	Tennessee St.	II <sup>C</sup>	1.23	\$61,500
Brockton Ave/Nice Ave.	New York St.	Wabash Ave	III	3.25	\$162,500
Brookside Ave.	San Mateo St.	Eureka St.	II	0.87	\$43,500
Church St.	Colton Ave.	College Ave.	III	0.08	\$1,200
Church St.	San Bernardino Ave.	College Ave.	II	0.91	\$45,500
Citrus Ave.	Eureka St.	Redlands Blvd.	III	0.73	\$10,950
Citrus Ave.	Redlands Blvd.	University St.	II	2.66	\$133,000
Citrus Ave.	University St.	Wabash Ave.	II <sup>A</sup>	1.60	\$80,000
Colton Ave.	Orange St.	Church St.	III	0.50	\$7,500
Crescent Ave.	San Jacinto St.	Elizabeth St.	III	0.40	\$6,000
Cypress Ave.	Cajon St.	Roosevelt Rd.	III	0.50	\$7,500
Cypress Ave.	Harp Place	Cajon St.	II	1.59	\$79,500
Cypress Ave.	Roosevelt Rd.	Citrus Ave.	II	0.52	\$26,000
Cypress Ave.	Terrancia Blvd.	Harp Place	III	0.14	\$2,100
Dearborn St.	5th Ave.	Lugonia Ave.	II <sup>B</sup>	1.52	\$50,000
East Valley Corridor Multi-Purpose Trail	San Bernardino Ave.	California St.	I	1.23	\$1,230,000
Fern Ave.	San Mateo Rd.	Redlands Blvd.	II	1.35	\$67,500
Fern Ave.	Terracina Blvd.	San Mateo Rd.	III	0.71	\$10,650
Ford St.	Colton Ave.	Sylvan Blvd.	III	0.17	\$2,550
Ford St.	Pennsylvania Ave.	Colton Ave.	II	0.75	\$37,500
Ford St.	San Bernardino Ave.	Pennsylvania Ave.	III	0.25	\$3,750
Ford St.	Sylvan Blvd.	Highland Ave.	II	0.69	\$34,500
Highland Ave.	Ford St.	Wabash Ave.	II	1.02	\$51,000
Mariposa Dr.	Canyon Rd.	Country Club Dr.	III	0.60	\$9,000
Mariposa Dr.	Rossmont Dr.	Canyon Rd.	II	0.10	\$5,000
Olive Ave.	Center St.	Citrus Ave.	II	0.76	\$38,000
Olive Ave.	Terracina Blvd.	Center St.	II <sup>B</sup>	1.30	\$65,000
Orange Blossom Trail	0.12m e/o Alabama St.	Tennessee St.	I	0.39	\$390,000
Orange Blossom Trail	Alabama St	0.12mi. e/o Alabama St	I	0.11	\$110,000
Orange Blossom Trail	Bryn Mawr Ave.	Nevada St.	I	1.40	\$1,400,000
Orange Blossom Trail	Grove St.	Colton Ave.	I	1.30	\$1,300,000
Orange Blossom Trail	Iowa St.	Alabama St.	I	0.25	\$250,000
Orange Blossom Trail	Nevada St	Iowa St	I	0.24	\$240,000
Orange Blossom Trail	Tennessee St.	Center St.	I	0.54	\$540,000
Palo Alto Dr.	Country Club Dr.	Sunset Dr.	III	0.95	\$14,250



Street/Path	From	To	Class	Length (mi.)	Cost Estimate
Pennsylvania Ave.	Karon St.	Ford St.	III	2.18	\$109,000
San Bernardino Ave.	Texas St.	Wabash Ave.	II	3.00	\$150,000
San Mateo St.	Brookside Ave.	Clifton Ave.	III	0.88	\$18,750
San Mateo St.	Clifton Ave.	Highland Ave.	II	0.37	\$18,500
San Mateo St.	Tennessee St.	Brookside Ave.	III	0.21	\$10,500
Tennessee St.	State St.	San Mateo St.	III	0.32	\$4,800
Terracina Blvd.	Barton Rd.	Olive Ave.	II <sup>B</sup>	0.76	\$38,000
			<b>Total</b>	<b>40.16</b>	<b>\$6,957,000</b>

TABLE NOTES – <sup>A</sup>: A green painted path in its entirety;  
 – <sup>B</sup>: A green painted path at conflict zones only;  
 – <sup>C</sup>: A green painted path at conflict zones only up to Lakeside Ave.

Table 5.95

Redlands Future Improvements

Street/Path	From	To	Class	Length (mi.)	Cost Estimate
6th St.	Stuart Ave.	Orange Blossom Trail	II	0.04	\$2,000
Alabama St.	Lugonia Ave.	Park Ave.	II	0.76	\$38,000
Alabama St.	N City Limit	Santa Ana River Trail	II	0.69	\$34,500
Alabama St.	Santa Ana River Trail	.28m N Palmetto Ave.	II	0.24	\$12,000
Alessandro Rd.	Crescent Ave.	San Timoteo Canyon Rd.	III	1.61	\$24,150
Alta Vista Dr.	Outer Highway 10	Sunset Dr.	III	0.84	\$12,600
Brockton Ave/Nice Ave.	Wabash Ave	Opal Ave.	II	0.25	\$12,500
Brookside Ave.	Terracina Blvd.	Lakeside Ave.	II	0.65	\$32,500
Cajon St.	Citrus Ave.	South Ave.	III	1.75	\$26,250
California St.	Mill St.	Barton Rd.	II	2.72	\$136,000
Center St.	State St.	Crescent Ave.	II	1.79	\$89,500
Church St.	Colton Ave.	Redlands Blvd.	III	0.66	\$9,900
Church St.	Santa Ana River Trail	San Bernardino Ave.	III	0.48	\$7,200
Colton Ave.	California St.	Dearborn St.	II	4.01	\$225,000
Colton Ave.	Dearborn St.	Orange Blossom Trail/Wabash Ave.	II	0.49	\$24,500
Dearborn St.	Pioneer Ave.	Lugonia Ave.	II	1.00	\$50,000
Elizabeth St.	Cressent Ave.	Mariposa Dr.	III	1.46	\$21,900
Eureka St.	State St.	Brookside Ave.	II	0.06	\$3,000
Fern Ave.	San Timoteo Canyon Rd.	Terracina Blvd.	II	0.37	\$18,500
Ford St.	Highland Ave.	Elizabeth St.	III	1.72	\$25,800
Ford St.	Santa Ana River Trail	San Bernardino Ave.	II	0.52	\$26,000
Garden St.	Cajon St.	Elizabeth St.	III	0.75	\$11,250

Street/Path	From	To	Class	Length (mi.)	Cost Estimate
Garnet Ave.	N City Limit	S City Limit	II	0.27	\$13,500
Greenspot Rd.	Highland City Limit	Florida Ave.	II	0.42	\$21,300
Grove St.	Brockton Ave.	Citrus Ave.	II	0.74	\$37,000
Henrietta St.	South Ave.	Elizabeth St.	III	0.21	\$3,150
Highland Ave.	Serpentine Dr.	Redlands Blvd	III	1.72	\$25,800
Hilton Ave/Sunset Dr.	Garden St.	Alta Vista Dr.	III	2.97	\$44,550
Lincoln St.	Lugonia Ave.	Highland Ave.	II	1.24	\$62,000
Live Oak Rd.	San Timoteo Canyon Rd	W City Limits	II	3.71	\$185,500
Lugonia Ave.	California St.	Wabash Ave.	II	5.00	\$250,000
Mariposa Dr.	Sunset Dr.	Wabash Ave.	III	1.03	\$15,450
Mountain View Ave.	Orange Blossom Trail	I-10 Ramp	II	0.27	\$13,500
Nevada St.	Lugonia Ave.	Barton Rd.	II	1.51	\$75,500
Nevada St.	Santa Ana River Trail	Palmeto Ave.	I	0.46	\$460,000
New York St.	Lugonia Ave.	Stuart Ave.	II	0.72	\$36,000
New York St.	Orange Blossom Trail	S End of New York St.	II	0.23	\$11,500
Opal Ave.	Santa Ana River Trail	San Bernardino Ave.	III	1.04	\$15,600
Orange Grove Trail	Bryn Mawr Ave.	San Bernardino Ave.	II	0.66	\$33,000
Orange Blossom Connector	Stuart Ave.	Redlands Blvd.	I	0.04	\$40,000
Orange Blossom Trail	Mountain View Ave.	Bryn Mawr Ave.	I	1.44	\$1,440,000
Orange Blossom Trail	New York St.	Naples Ave.	I	2.44	\$3,740,000
Orange St.	Colton Ave.	Citrus Ave.	III	0.50	\$7,500
Orange St.	N. City Limit	Colton Ave.	II	2.49	\$124,500
Palmetto Ave.	California St.	Nevada St.	I	0.50	\$500,000
Park Ave.	Orange Blossom Trail	Kansas St.	II	1.16	\$58,000
Pioneer Ave.	Buckeye St.	Wabash Ave.	II	3.75	\$187,500
Redlands Blvd.	Fern Ave.	Ford St.	III	1.37	\$20,550
Redlands Blvd.	Colton Ave.	Fern Ave.	II	2.19	\$109,500
Reservoir Rd.	Ford St.	Wabash Ave.	III	1.11	\$16,650
San Bernardino Ave.	E Doughnut Hole	Texas St.	II	0.67	\$33,500
San Bernardino Ave.	Orange Blossom Trail	California St.	II	1.00	\$50,000
San Jacinto St.	Highland Ave.	Crescent Ave.	III	0.16	\$2,400
San Timoteo Canyon Rd.	Barton Rd.	Live Oak Rd.	III	4.17	\$62,550
San Timoteo Creek Trail	Beaumont Ave.	S. City Limit	I	3.87	\$3,870,000
Santa Ana River Trail	Mountain View Ave.	Greenspot Rd.	I	11.36	\$11,360,000

Street/Path	From	To	Class	Length (mi.)	Cost Estimate
Serpentine Dr./Sunset Dr.	Highland Ave.	Alessandro Rd.	III	1.28	\$19,200
South Ave.	Cajon St.	Henrietta St.	III	0.22	\$3,300
State St.	Alabama St.	Eureka St.	II	1.37	\$68,500
Stuart Ave.	New York St.	6th St.	II	0.84	\$42,000
Sunset Dr. S	Alessandro Rd.	Alta Vista Dr.	III	3.41	\$51,150
Tennessee St.	San Bernardino Ave.	State St.	II	1.53	\$76,500
Terracina Blvd.	Olive Ave.	Smiley Heights Dr.	II	0.51	\$25,500
Texas St.	Santa Ana River Trail	State St.	II	2.21	\$110,500
University St.	San Bernardino Ave.	Cypress Ave.	II	1.68	\$84,000
Wabash Ave.	Reservoir Rd.	Sunset Dr.	III	0.43	\$6,450
Wabash Ave.	Sesums Dr.	Reservoir Rd.	II	3.65	\$182,500
Zanja Creek Trail	Orange Blossom Trail	Grove St.	I	0.69	\$690,000
Zanja/Orange Connect	Zanja Creek Trail	Orange Blossom Trail	II	0.10	\$5,000
			<b>Total</b>	<b>101.20</b>	<b>\$25,133,650</b>

### Proposed Improvements

Future improvements to the non-motorized network for the City of Redlands will create a grid of non-motorized infrastructure. Additionally, a significant investment in Class I Bikeways will provide a number of access controlled, higher speed corridors for citizens and bike commuters in the City. Future improvements focus on a balanced approach to the development of Class I, Class II and Class III facilities. All proposed future improvements are included in Table 5.95 above.

The priority for the City of Redlands is completion of the Orange Blossom Trail. This non-trail will serve as a critical component of the City's non-motorized trail system. When the entire system is completed, the City will have constructed an additional 101.20 miles of Class I, Class II and Class III, providing internal connectivity to the residents of Redlands and establishing connections to the non-motorized networks of adjacent cities including, Highland and Loma Linda and the County of San Bernardino.

Table 5.96

Priority Improvements

Street/Path	From	To	Class	Length (mi.)	Cost Estimate
Orange Blossom Trail	Mountain View	Opal Ave.	I	3.88	\$3,880,000
			<b>Total</b>	<b>3.88</b>	<b>\$3,880,000</b>

**Pedestrian Facilities**

The City has also identified opportunities to enhance pedestrian facilities. These are described in the 2017 *SBCTA Safe Routes to School Plan (SRTS)* and in the 2017 *SBCTA Points of Interest Pedestrian Plan (PIPP)*. The *SRTS* focuses on improving access to neighborhood schools listed in Table 5.97, while the *PIPP* focuses on improving access to other community assets listed in Table 5.98. Specific improvement recommendations per project are detailed in the *SRTS Plan Phase II – Volume 2* for items in Table 5.97 and the *PIPP* for items in Table 5.98.

Table 5.97

SRTS Opportunities

Project	Potential Connection to Bikeways, by Status and Class, within ¼ Mile of Project	Number of Improvements Identified	Cost Estimate
Clement M.S.	Existing Class II, III & Planned Class II	9	\$281,267
Franklin E.S.	Existing Class II, III & Planned Class I, II, III	8	\$96,188
Lugonia E.S.	Existing Class II, III & Planned Class II	11	\$151,425
		<b>Total</b>	<b>\$528,880</b>

Table 5.98  
PIPP Opportunities

Project	Potential Connection to Bikeways, by Status and Class, within ¼ Mile of Project	Proposed Project Ranking
City Hall, Smiley Park, and Library	Existing Class, II, III & Planned Class II, III	1
Brookside Plaza Shopping Center & Brookside Park	Existing Class II & Planned Class II	2
Citrus Valley High School	Planned Class I, II	NR <sup>A</sup>
Ford Park	Existing Class II & Planned Class III	NR <sup>A</sup>
Prospect Park	Existing Class II & Planned Class III	NR <sup>A</sup>
Redlands Community Center/Texonia Park	Existing Class III & Planned Class II	NR <sup>A</sup>
Redlands Community Park, Lugonia Elementary, and Clement Middle	Existing Class II, III & Planned Class II	NR <sup>A</sup>
Redlands High School	Existing Class II & Planned Class II, III	NR <sup>A</sup>
University of Redlands	Existing Class III & Planned Class I, II	NR <sup>A</sup>

TABLE NOTES – <sup>A</sup>: NR = “Not Ranked”, listed as potential project locations and not included in above map.

**Municipal Code**

The City of Redlands has not adopted Municipal Code specific to non-motorized transportation or the placement of non-motorized transportation facilities.

**End of Trip Facilities**

The City of Redlands has bike racks dispersed throughout the City, typically at retail centers, schools and multi-unit housing complexes.

**Multimodal Connectivity**

Table 5.99

Location of Multi-Modal Connections

Facility	Facility Type	Facility Location
City-wide Bus Stops	Bus Stops	Throughout City

**Collisions Involving Bicyclists**

Table 5.100

Data for Collisions Involving Bicyclists

Parameter	Collision Rate
Total # of Bicycle Collisions from 2012-2016	100
Total # of Bicycle Fatalities from 2012-2016	0
Total # of Bicycle Injuries from 2012-2016	102
Average # of Bicycle Collisions Per Year	20.0
Average Bicycle Collision Rate per 1000/year <sup>1</sup>	0.28

Notes:

1. Rate is calculated using SWITRS collision data and population figures by the California Department of Finance

**Safety and Education Programs**

The City of Redlands Police Department participates in an annual community bicycle giveaway program that includes providing training on bicycle safety, providing bicycle helmets and safety gear and bicycles to needy families within the City.



## City of Rialto

### **Population**

107,041

### **City Overview**

The City of Rialto is located in the central San Bernardino Valley. The City shares its boundaries with the cities of Colton, Fontana and San Bernardino as well as unincorporated areas of Riverside and San Bernardino counties. The City is four miles wide and 8.5 miles long and comprises an incorporated area of 28 square miles.

### **Land Use**

Rialto's land use pattern is defined by nearly 100 years of historical growth. The historic downtown and surrounding older neighborhoods, with smaller residential lots and small central business district provide a walkable urban core. Suburban tract homes from the 1950s and 1960s, away from downtown, have defined much of the City. Newer residential neighborhoods have filled the northern areas.

Commercial uses are focused along Foothill Boulevard, Riverside Avenue, Valley Boulevard, Renaissance Parkway and Baseline Road. These corridors and intersections, along with downtown, constitute the City's major commercial areas.

### **Existing Conditions:**

Rialto has experienced growth in its non-motorized bicycle network since the last update to the Non-Motorized Transportation Plan. The City has completed a number of Class II improvements in the northern area of the City and it has built a 1.23 mile segment of Class I facility from Maple Avenue to Cactus Avenue. In total, the City has 1.23 miles of Class I and 12.5 miles of Class II.

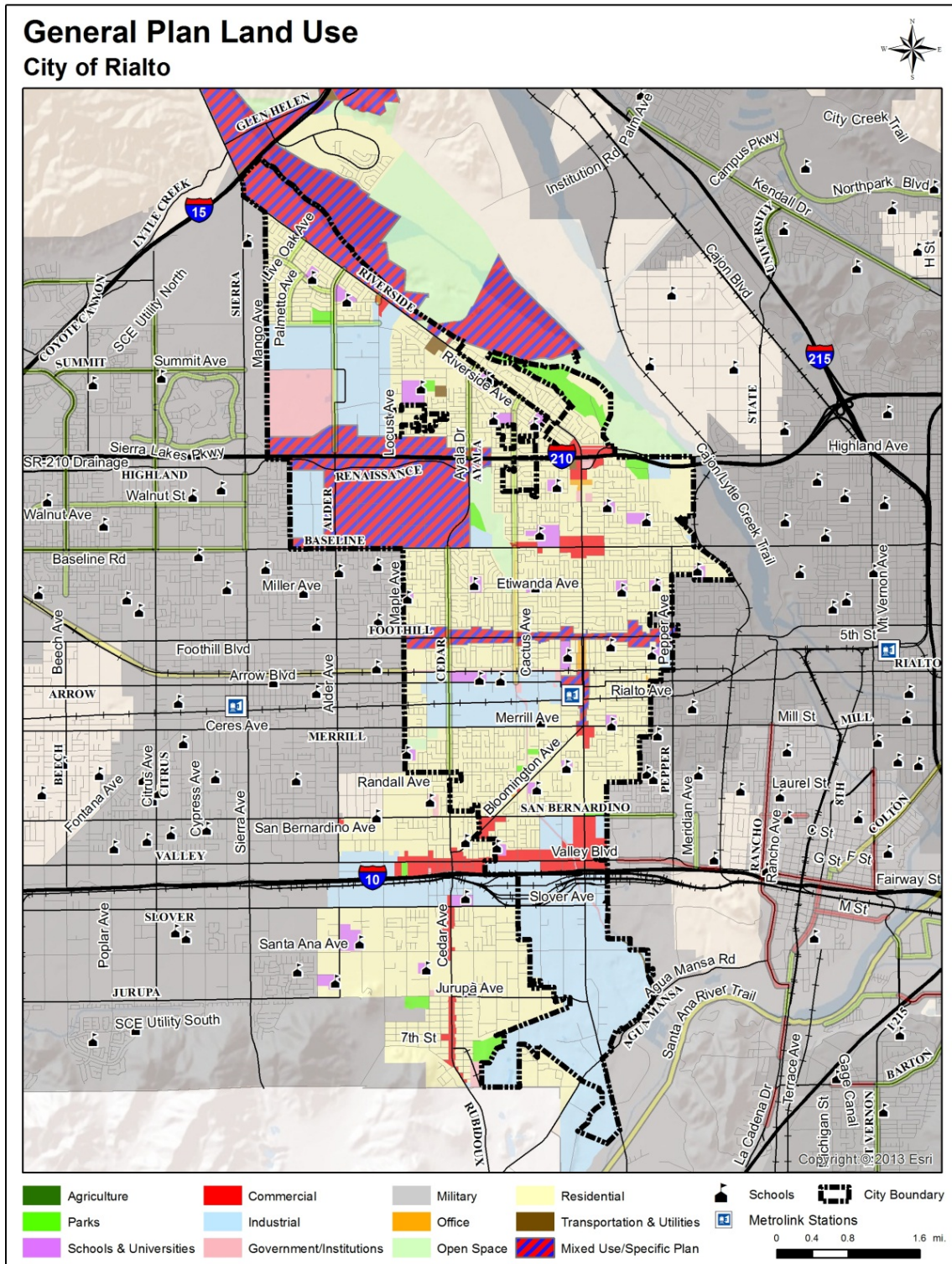
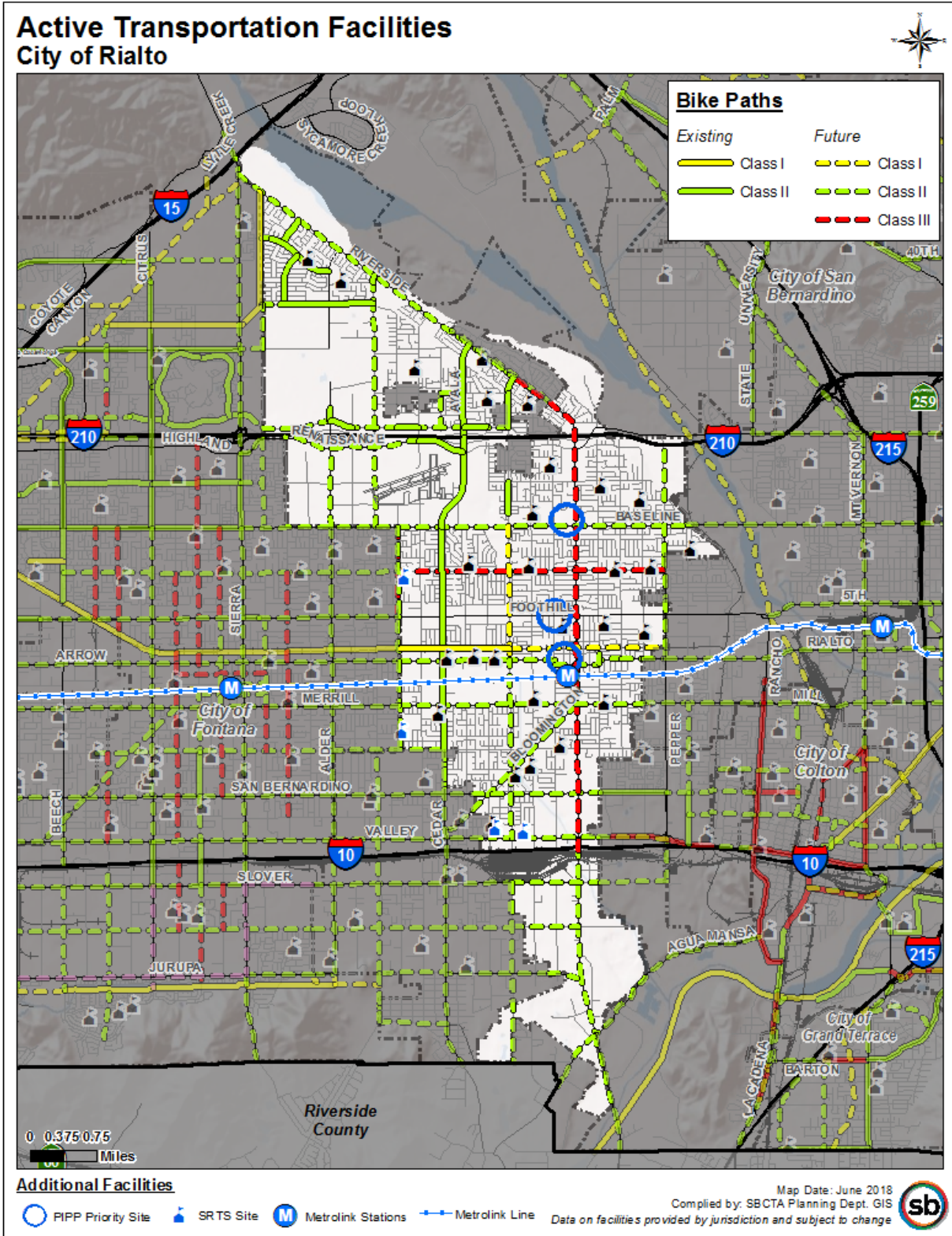

Figure 5.35



C:\Users\christopher\Documents\Projects\BikePlan\_Feb16\startDataDrivenMaps\ATP\_Portrait.mxd

Figure 5.36  
5-150



Table 5.101

Rialto Existing Conditions

Street/Path	From	To	Class	Length (mi.)	Cost Estimate
Alder Ave.	Casmalia St	775'.N Casmalia St	II	0.14	\$7,400
Ayala Dr.	Riverside Ave.	SR-210	II	1.05	\$52,500
Ayala Dr.	SR-210	Baseline Rd.	II	1.09	\$54,000
Cactus Ave.	Mariposa St.	Walnut Ave.	II	0.35	\$17,500
Cactus Ave.	Casmalia St.	Bohnert Ave	II	2.0	\$100,000
Casa Grande Dr.	Ponderosa Ave.	Locust Ave.	II	1.05	\$52,500
Casmalia St.	Alder Ave.	Laurel Ave.	II	0.24	\$12,000
Casmalia St.	1300'E/O Locust Ave.	Linden Ave	II	0.24	\$12,000
Casmalia St.	Ayala Dr	Spruce Ave	II	0.24	\$12,000
Cedar Ave.	Base Line Rd.	Randall Ave.	II	2.50	\$125,000
Country Club Dr.	Riverside Ave.	Bohnert Ave.	II	0.19	\$9,500
Live Oak Ave.	Riverside Ave.	Terra Vista Dr.	II	0.64	\$32,000
Locust Ave.	Riverside Ave.	Buena Vista Dr.	II	0.07	\$3,500
Pacific Electric Trail	Maple Ave	Cactus Ave	I	1.23	\$1,230,000
Palmetto Ave.	Terra Vista Dr.	Casa Grande Dr.	II	0.59	\$29,500
Renaissance Pkwy	Ayala Dr.	Linden Ave	II	0.31	\$15,500
Terra Vista Dr.	Dove Tree Ave.	Alder Ave.	II	0.76	\$38,000
			<b>Total</b>	<b>12.69</b>	<b>\$1,802,900</b>

*Past Investment in Non-Motorized Infrastructure*

The improvements included in Table 5.101 above constitute a significant investment into the non-motorized transportation infrastructure of Rialto. Based on planning level estimates, the value of the improvements implemented throughout the City is \$1,802,900.

Table 5.102

Rialto Future Improvements

Street/Path	From	To	Class	Length (mi.)	Cost Estimate
Agua Mansa Rd.	0.07mi. N El River Dr.	Riverside Ave.	II	0.33	\$16,500
Alder Ave.	Baseline Rd.	Renaissance Pkwy	II	0.86	\$43,500
Baseline Rd.	Maple	E City Limit	II	3.25	\$162,500
Bloomington Ave.	Larch St.	Riverside Ave.	II	1.76	\$88,000
Bonhert Ave.	Cedar Ave.	Ayala Dr.	II	0.25	\$12,500
Cactus Ave.	Rialto Ave.	El Rivino Rd.	II	3.16	\$158,000
Cactus Ave.	Rialto Ave.	Baseline Rd	I	1.50	\$1,500,000
Casa Grande Dr.	Mango Ave.	Ponderosa Ave.	II	0.19	\$9,500
Casmalia Ave.	Laurel Ave.	1300' E/O Locust Ave.	II	2.00	\$100,000

Street/Path	From	To	Class	Length (mi.)	Cost Estimate
Cedar Ave.	0.06mi s/o Bonhert Ave.	Casamalia Ave.	II	0.31	\$15,500
Cedar Ave.	Sequoia Ave.	S/o Miramont St.	II	0.31	\$15,500
Etiwanda Ave.	W City Limit	E City Limit	III	3.00	\$45,000
Jurupa Ave.	0.09mi W Willow Ave	Riverside Ave.	I	0.37	\$18,500
Locust Ave.	Casmalia Ave.	Baseline Rd.	II	1.12	\$56,000
Locust Ave.	Riverside Ave.	Casmalia St.	II	1.63	\$81,500
Maple Ave.	Baseline Rd.	Foothill Blvd	III	1.00	\$15,000
Maple Ave.	Bonnie View Dr.	Randall Ave.	II	0.72	\$36,000
Merrill Ave.	Maple Ave.	Eucalyptus Ave.	II	2.75	\$137,500
Pacific Electric Trail	Cactus Ave.	Pepper Ave.	I	1.77	\$1,770,000
Palm Ave	Rialto Ave.	Metrolink Station	II	0.12	\$6,000
Pepper Ave.	Baseline Rd.	Foothill Blvd	II	1.00	\$50,000
Pepper Ave.	Spruce St.	Pacific Electric Trail	II	0.51	\$25,800
Pepper Ave.	Winchester Dr.	SR-210	II	0.56	\$28,300
Renaissance Pkwy	Linden Ave	W City Limit	II	2.50	\$125,000
Rialto Ave.	Acacia Ave.	Eucalyptus	II	0.25	\$12,500
Rialto Ave.	Cactus Ave.	Willow Ave.	II	0.50	\$25,000
Rialto Ave.	Maple Ave.	Cactus Ave.	II	1.25	\$62,500
Rialto Ave.	Sycamore Ave.	Acacia Ave.	II	0.25	\$12,500
Rialto Ave.	Willow Ave.	Sycamore Ave.	II	0.50	\$25,000
Riverside Ave.	Cactus Ave.	I-10	III	6.33	\$93,600
Riverside Ave.	I-10	Agua Mansa Rd.	II	2.08	\$104,000
Riverside Ave.	Sierra Ave.	Cactus Ave.	II	3.85	\$192,500
San Bernardino Ave.	W City Limit	E City Limit	II	1.44	\$72,000
Santa Ana Ave.	Cactus Ave.	Riverside Ave.	II	0.75	\$37,500
Slover Ave.	Cactus Ave.	Sycamore Ave.	II	1.00	\$50,000
Sycamore Ave.	Pacific Electric Trail	SE Rialto Ave	II	0.18	\$9,000
Terra Vista Dr.	Mango Ave.	Dove Tree Ave.	II	0.11	\$5,500
Valley Blvd.	Spruce Ave.	E City Boundary	II	1.17	\$58,500
Willow Ave.	NW Rialto Ave	SE Rialto Ave	II	0.05	\$2,500
			<b>Total</b>	<b>50.68</b>	<b>\$5,278,700</b>

Table 5.103

Priority Improvements

Street/Path	From	To	Class	Length (mi.)	Cost Estimate
Baseline Rd.	Maple Ave.	E City Limit	II	3.25	\$162,500
Etiwanda Ave.	W City Limit	E City Limit	III	3.00	\$45,000
Maple Ave.	Baseline Rd.	Foothill Blvd	III	1.00	\$15,000
Merrill Ave.	Maple Ave.	Eucalyptus Ave.	II	2.75	\$137,500
Pepper Ave.	Baseline Rd.	Foothill Blvd	II	1.00	\$50,000
Riverside Ave.	Baseline Rd.	Foothill Blvd	III	1.00	\$15,000
			<b>Total</b>	<b>12.0</b>	<b>\$425,000</b>

**Proposed Improvements**

Future improvements to the non-motorized network for the City of Rialto will continue along the major transportation corridors throughout the City. Most of the City’s future improvements focus on additional Class II facilities, but some new Class I and Class III facilities are proposed. The marquee future improvement is the eastern extension of the Pacific Electric Trail from Cactus Avenue to Pepper Avenue. A table of future improvements is included in Table 5.102 above.

The priority for the City of Rialto is to build the non-motorized network to connect the schools along the Etiwanda Corridor to the Pacific Electric Trail and the Multi-Modal facilities at the Rialto Metrolink Station and the citywide bus stops. Rialto will be building a dedicated multi-path trail along the Rialto Cactus Flood Control Channel the parallel the Cactus Avenue from Rialto Avenue to Baseline Road. A table of priority improvements is included in Table 5.103.

**Pedestrian Facilities**

The City has also identified opportunities to enhance pedestrian facilities. These are described in the 2017 *SBCTA Safe Routes to School Plan (SRTS)* and in the 2017 *SBCTA Points of Interest Pedestrian Plan (PIPP)*. The *SRTS* focuses on improving access to neighborhood schools listed in Table 5.104, while the *PIPP* focuses on improving access to other community assets listed in Table 5.105. Specific improvement recommendations per project are detailed in the *SRTS Plan Phase II – Volume 2* for items in Table 5.104 and the *PIPP* for items in Table 5.105.



Table 5.104  
SRTS Opportunities

Project	Potential Connection to Bikeways, by Status and Class, within ¼ Mile of Project	Number of Improvements Identified	Cost Estimate
Joe Baca M.S.	Planned Class II	7	\$80,035
Maple E.S.	Planned Class II	9	\$623,049
Ruth Grimes E.S.	Planned Class II	9	\$171,541
Virginia Primrose E.S.	Planned Class II, III	10	\$170,538
<b>Total</b>		<b>35</b>	<b>\$1,045,163</b>

Table 5.105  
PIPP Opportunities

Project	Potential Connection to Bikeways, by Status and Class, within ¼ Mile of Project	Proposed Project Ranking
Downtown & Civic Center	Planned Class I, II, III	1
Rialto Shopping Center & Eisenhower High	Planned Class II, III	2
Foothill Blvd Retail Center	Planned Class III	3
Fergusson Park & Kucera Middle School	Existing Class II	NR <sup>A</sup>
Flores Park/Helen Dollahan Elementary School	Planned Class III	NR <sup>A</sup>
Frisble Park	None	NR <sup>A</sup>
Rialto City Park	Planned Class II, III	NR <sup>A</sup>
Rialto Metrolink Station	Planned Class II, III	NR <sup>A</sup>

TABLE NOTES – <sup>A</sup>: NR = “Not Ranked”, listed as potential project locations and not included in above map.

**Municipal Code**

Rialto Municipal Code 18.59.030 - Design standards - provides the following requirements related to pedestrian access and circulation:

The following design standards shall be incorporated into the precise plan of design approval process for all new and revised nonresidential and multifamily developments of ten or more units, except as specifically provided below:

- A. Bicycle parking facilities to include bicycle racks and/or secured bicycle lockers shall be provided at a rate of one bicycle space per thirty parking spaces with a minimum requirement of three bicycle spaces.
- B. On-site pedestrian walkways and bicycle facilities shall be provided connecting each building in a development to public streets.
- C. A minimum of one shower facility accessible to both men and women shall be provided for persons bicycling or walking to work for all new nonresidential

development meeting the city's adopted congestion management plan (CMP) thresholds of two hundred fifty or more peak hour trips.

- J. The city will participate in the implementation of the adopted countywide bicycle plan to conform with Southern California Associated Governments (SCAG) Regional Mobility Element.
- K. Sidewalks shall be installed or widened when possible, as approved by the city engineer, to accommodate pedestrians

**End of Trip Facilities**

The City of Rialto has bike racks dispersed throughout the City, typically at retail centers, schools and multi-unit housing complexes and at the Metrolink Station.

**Multimodal Connectivity**

Table 5.106

Multimodal Connections

Facility	Facility Type	Facility Location
Rialto Metrolink Station	Train Station	Riverside Dr.
City-wide Bus Stops	Bus Stops	Throughout City

In 2018, Caltrans awarded Rialto a sustainable planning grant to provide a Rialto Active Transportation Plan that will provide a clear and comprehensive framework for safer, more convenient non-motorized transportation options throughout the City. The plan will identify non-motorized routes and associated improvements for bicycle and pedestrian connectivity and safety, expanding bicycle networks; improving pedestrian circulation; reducing vehicle trips; creating complete streets; prioritizing access to transit; creating a first and last mile transit plans; and building a healthy and livable community.

**Collisions Involving Bicyclists**

Table 5.107

Data for Collisions Involving Bicyclists

Parameter	Collision Rate
Total # of Bicycle Collisions from 2012-2016	88
Total # of Bicycle Fatalities from 2012-2016	1
Total # of Bicycle Injuries from 2012-2016	87
Average # of Bicycle Collisions Per Year	17.6
Average Bicycle Collision Rate per 1000/year <sup>1</sup>	0.16

Notes:

1. Rate is calculated using SWITRS collision data and population figures by the California Department of Finance

**Safety and Education Programs**

In 2017, the City of Rialto began to implement a Safe Routes to School Plan (SRTS Plan) including bicycle safety and education, encouragement and enforcement awareness, engineering and evaluation programs in all twenty-nine schools (29) within the Rialto Unified School District. The goal of the program is to increase the bicycle awareness, safety, and education among school children and families living in Rialto. The Engineering component of the Rialto SRTS Plan identified an estimated \$17 million of infrastructure improvements required within a ¼ mile radius of the school site for a safer walking and bicycling environment.

In 2017, Rialto partnered with SBCTA and SCAG to host a SCAG initiative Go- Human on April 19, 2017. The event branded, **Right on Rialto**, was an enormous success with approximately 2,000 people attending. The City of Rialto applied for the **Go Human** grant to engage the public and promote Active Transportation in Rialto through education, health and wellness, advocacy, information sharing, and activities to encourage more use of active transportation while emphasizing the safety of the cyclists and pedestrians within the community.



In addition, the Healthy Rialto initiative since 2014 annually sponsors a Bike Rodeo Event to promote biking and walking in Rialto. The Bike Rodeo provides an opportunity for local business to give away bicycle, and helmets, and lessons in promoting safe road habits. Throughout the year, the city sponsors multiple run/walk events around the city that promotes walking and running both as a health initiative and as an endorsing lifestyle changes in alternative modes of transportation. The events encourage road safety awareness and healthy living for the community.

## City of San Bernardino

### **Population**

212,639

### **City Overview**

The City of San Bernardino is the largest City and the county seat of San Bernardino County, California. The City encompasses approximately 81 square miles at the heart of the central San Bernardino Valley. The City also serves as the gateway to the High Desert and Mountains areas of the County.

### **Land Use**

The City's housing stock is on average older than most of the rest of the San Bernardino Valley. However, a significant amount of new housing has been added to the northwest area of the City known as Verdemon. Most of the City's housing stock is clustered around I-215 and SR-210, while commercial and industry tends to be located south of Highland Avenue.

San Bernardino is one of the employment hubs for San Bernardino County, as it is one of the few San Bernardino County cities with a downtown. The government sector is the single largest employment sector for the city, with the City of San Bernardino, County of San Bernardino, Caltrans, Omnitrans, California State University, and the San Bernardino City School District among the city's largest employers. The City is also home to the Burlington Northern Santa Fe (BNSF) intermodal rail yard and the former Norton Air Force Base, which is currently being redeveloped as the San Bernardino International Airport.

### **Existing Conditions:**

The City of San Bernardino has experienced growth in its non-motorized bicycle network since the last update to the Non-Motorized Transportation Plan. The City has completed one segment of the Santa Ana River Trail, a Class I trail that will ultimately connect the San Bernardino Mountains to the Pacific Ocean.

The City has also constructed a number of Class II improvements, mostly in the northern residential neighborhoods the City. In total, the City contains 17.33 miles of bicycle infrastructure within its limits, 2.55 miles of Class I and 14.78 miles of Class II.

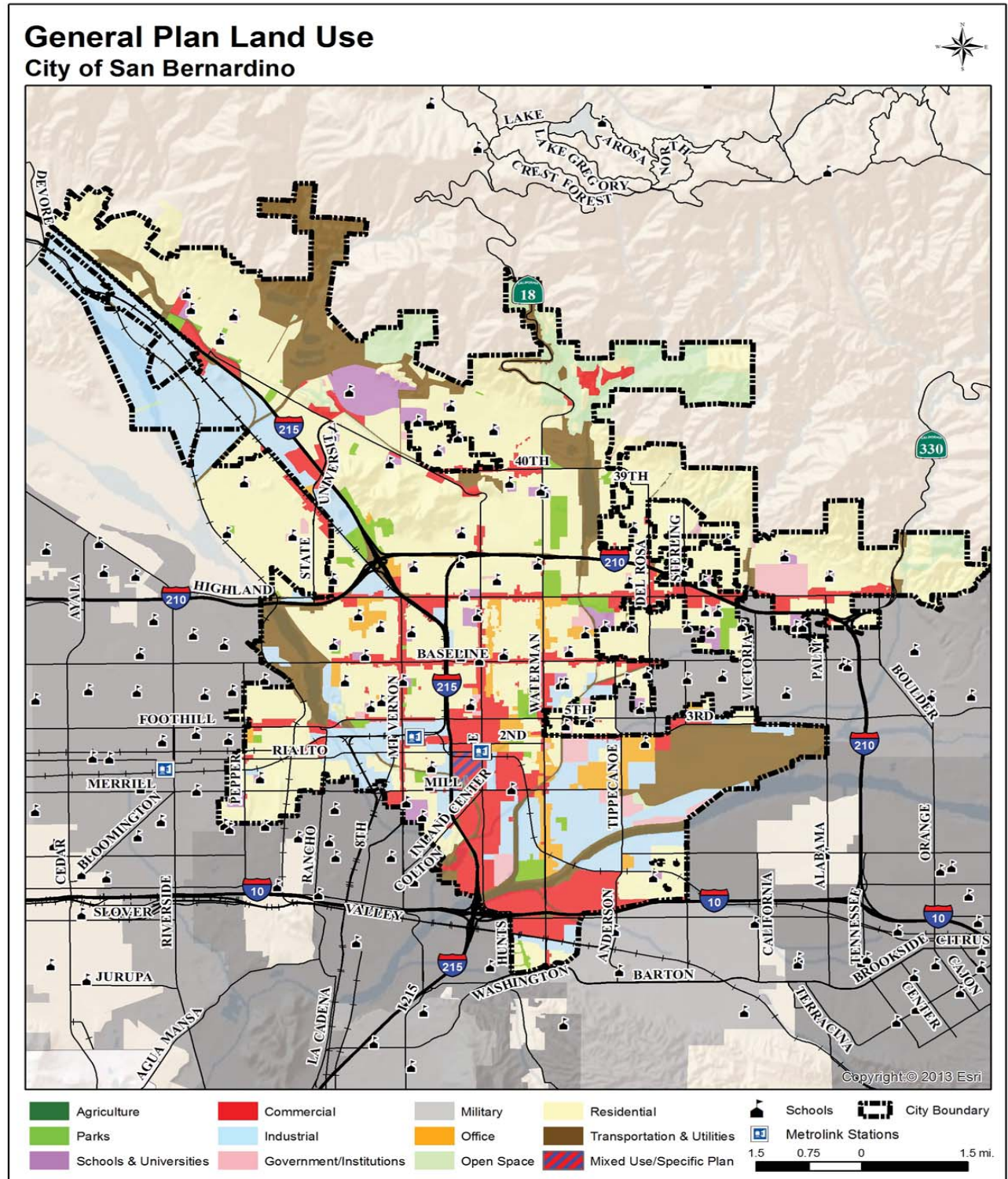

Figure 5.37



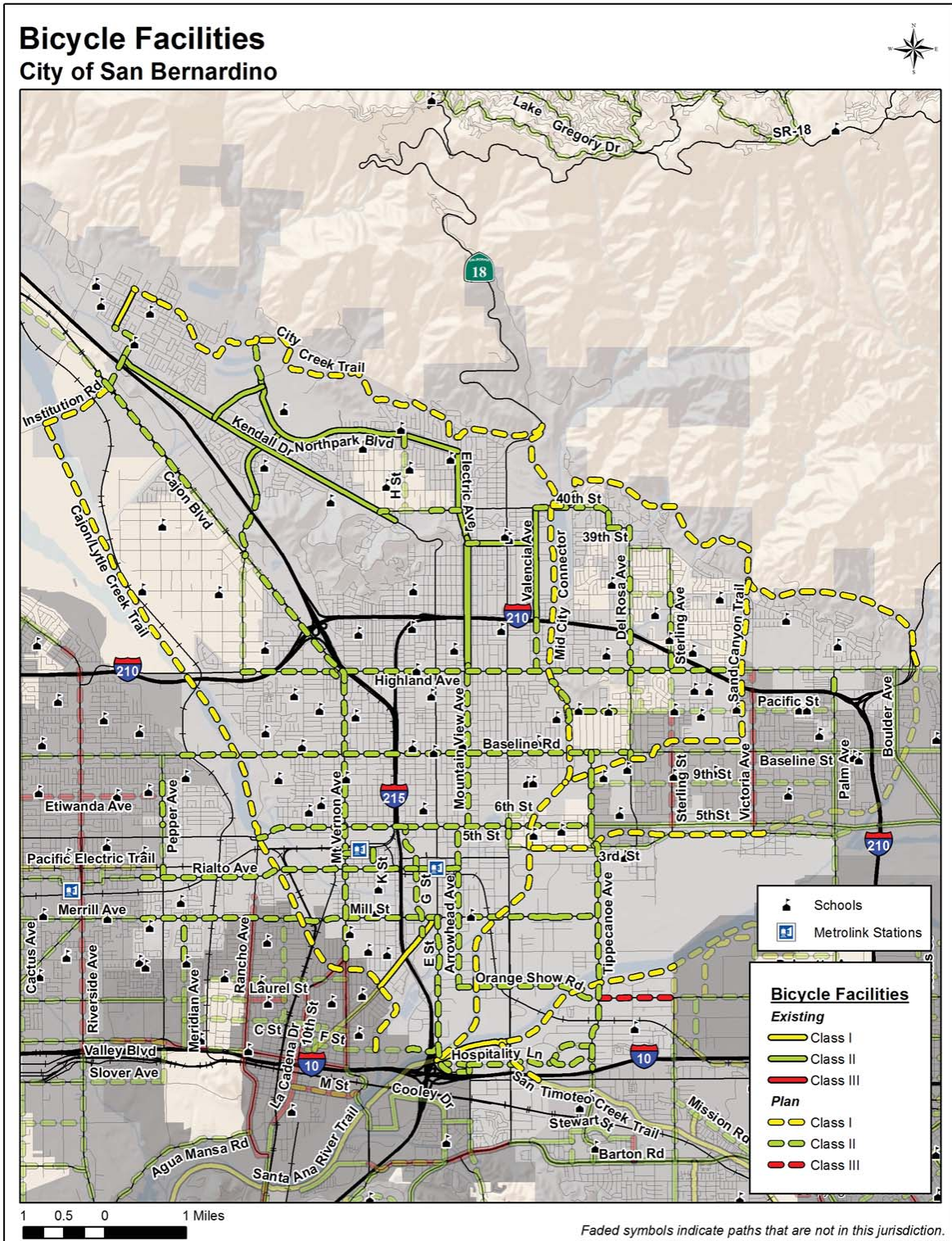

Figure 5.38



Table 5.108

San Bernardino Existing Conditions

Street/Path	From	To	Class	Length (mi.)	Cost Estimate
Campus Pkwy.	Kendall Dr.	Northpark Blvd.	II	0.72	\$36,000
Chestnut Ave. Bike Path	Ohio Ave.	Irvington Ave.	I	0.53	\$530,000
Electric Ave.	Northpark Blvd.	Mountain View Ave./38th St.	II	1.07	\$53,500
Inland Center Dr. Bike Path	S City Limits	Mill St.	I	1.07	\$1,070,000
Kendall Dr.	Palm Ave.	Shandin Hills Cr.	II	3.89	\$194,500
Mountain View Ave.	Electric Ave./38th St.	23rd St.	II	3.06	\$153,000
Northpark Blvd.	Campus Pkwy.	Electric Ave.	II	2.99	\$149,500
Parkdale Dr.	Sierra Way	Valencia Ave.	II	0.71	\$35,500
Santa Ana River Trail	W. City Limit	Waterman Ave.	I	0.95	\$950,000
University Pkwy.	Northpark Blvd.	Varsity Ave.	II	1.00	\$50,000
Valencia Ave.	40th St.	30th St.	II	1.34	\$67,000
			<b>Total</b>	<b>17.33</b>	<b>\$3,289,000</b>

*Past Investment in Non-Motorized Infrastructure*

The improvements included in Table 5.108 above constitute a significant investment into the non-motorized transportation infrastructure of San Bernardino. Based on planning level estimates, the value of the improvements implemented throughout the City is \$2,219,000.

**Proposed Improvements**

Future improvements to the non-motorized network for the City of San Bernardino will continue along the major transportation and drainage corridors throughout the City. Most of the City’s future improvements focus on additional Class I facilities, but a supportive Class II network is also proposed. A table of future improvements is included in Table 5.109 below.

At this time, the City of San Bernardino has several priority improvements identified. The first group of priority improvements includes the construction of bike lanes on G Street from Inland Center Dr. to Rialto Ave. and the construction of bike lanes on Rialto Ave. from G St. to E St. The second priority improvement within the City is the eastern extension of the Santa Ana River Trail from Waterman Ave. to Mountain View Ave. While the project is within the City of San Bernardino, the County of San Bernardino Department of Parks and Recreation has taken the lead on the project development and delivery.

When finished constructing its future bicycle network, the City will have added an additional 102.79 miles of Class I and II facilities, creating a substantial network of Class I bikeways and a supportive Class II bike lane network, with an additional 0.91 miles of Class III bike routes. The improvements will position the City as a hub of non-motorized transportation in the San Bernardino Valley and provide a boost to the accessibility and connectivity throughout the Central and Eastern San Bernardino Valley.

Table 5.109

San Bernardino Future Improvements

Street/Path	From	To	Class	Length (mi.)	Cost Estimate
3rd St.	Mt. Vernon Ave.	K St.	II	0.34	\$17,000
39th St.	Mountain Ave.	Del Rosa Ave.	II	0.25	\$12,500
40th St.	0.02mi. W Conejo Dr.	Sonora St.	II	0.17	\$8,500
40th St.	0.06mi. W Johnson St.	Electric Ave.	II	0.34	\$17,000
40th St.	Kendall Dr.	0.03mi E 3rd Av.	II	0.09	\$4,500
40th St.	Valencia Ave.	0.08mi W Golden Ave.	II	0.57	\$28,500
5th St.	Cajon/Lytle Creek Trail	H St.	II	1.83	\$91,500
5th St.	H St.	Tippecanoe Ave.	II	2.28	\$114,000
Arrowhead Ave.	5th St.	Orange Show Rd.	II	1.97	\$98,500
Baseline Rd.	Glasgow Ave.	Yates St.	II	0.05	\$2,500
Baseline Rd.	Tippecanoe Ave.	0.02mi. E Conejo Dr.	II	0.18	\$9,000
Baseline Rd.	W City Limit	E City Limit	II	4.88	\$244,000
Cajon Blvd.	California St.	Mt. Vernon Ave.	II	1.67	\$83,500
Cajon Blvd.	N City Limit	June St.	II	1.76	\$88,100
Cajon/Lytle Creek Trail			I	9.24	\$9,240,000
City Creek Trail	Mid City Connector	Palm Ave.	I	19.81	\$19,810,000
City Creek Trail Extension	Chestnut Ave. Bike Trail	Palm Ave.	I	0.27	\$270,000
Del Rosa Ave.	39th St.	Foothill Dr.	II	0.25	\$12,500
Del Rosa Ave.	Date St.	Del Rosa Dr.	II	0.69	\$34,500
Del Rosa Ave.	Eureka St.	Marshall Blvd.	II	0.18	\$9,000
Del Rosa Dr.	Baseline St.	San Canyon Trail	II	0.08	\$4,000
Devils Canyon Rd.	Ben Canyon Rd.	City Creek Trail	II	0.45	\$22,500
E St.	Mill St.	Orange Show Rd.	II	0.86	\$43,000
E St.	Orange Show Rd.	Hunts Ln.	II	1.33	\$66,500
Fairway Dr.	Auto Plaza Dr.	E St.	II	0.39	\$19,500
G St.	Rialto Ave.	Inland Center Dr.	II	0.83	\$41,500
H St.	Northpark Blvd	Hills Dr./52nd St.	II	0.17	\$8,500
H St./G St.	5th St.	Rialto Ave.	II	0.56	\$28,000
Harriman Pl.	Hospitality Ln.	Tippecanoe Ave.	II	0.51	\$25,500
Highland Ave.	State St.	Rockford Ave.	II	6.11	\$305,500
Hospitality Ln.	E St.	Hunts Ln.	II	0.34	\$17,000
Hospitality Ln.	Hunts Ln.	Tippecanoe Ave.	II	1.63	\$81,500
Hunts Ln.	Hospitality Ln.	E St.	II	0.08	\$4,000

*NMTP - Revised June 2018 - City of San Bernardino*

Institution Rd.	N end of Cajon/Lytle Creek Trail	Cajon Blvd.	I	0.91	\$910,000
Irvington Ave.	Chestnut Ave.	Palm Ave.	II	0.26	\$13,000
K St.	3rd St.	Rialto Ave.	II	0.22	\$11,000
Meridian Ave.	Mill St.	Randall Ave.	II	0.50	\$25,000
Mid City Connector	40th St.	Santa Ana River Trail	I	7.46	\$7,460,000
Mill St.	Eucalyptus	Tippecanoe Ave.	II	6.00	\$300,000
Mountain Ave.	Sonora St.	39th St.	II	0.18	\$9,000
Mountain View Ave.	23rd St.	5th St.	II	2.04	\$102,000
Mt Vernon Ave.	Highland Ave.	Grant St.	II	3.59	\$179,500
Orange Show Rd.	E St.	Tippecanoe Ave.	II	1.75	\$87,500
Pacific St.	Perris Hill Park Rd.	Dwight Way	II	0.55	\$27,500
Palm Ave.	Highland Ave.	Atlantic Ave.	II	0.25	\$12,500
Palm Ave.	Kendall Dr.	Cajon Blvd.	II	0.39	\$20,000
Palm Ave.	Little League Dr.	Irvington Ave.	II	0.28	\$14,000
Parkdale St.	Mountain View Ave.	Sierra Way	II	0.11	\$5,500
Pepper Ave.	9 <sup>th</sup> St.	Spruce St.	II	0.50	\$25,450
Pepper Ave.	Pacific Electric Trail	Rialto Ave.	II	0.13	\$6,500
Perris Hill Park Rd	21st St	Gilbert St	II	0.55	\$27,500
Rialto Ave.	E St.	Arrowhead Ave.	II	0.26	\$13,000
Rialto Ave.	Eucalyptus Ave.	Pepper Ave.	II	0.25	\$12,500
Rialto Ave.	G St.	E St.	II	0.25	\$12,500
Rialto Ave.	Mt. Vernon Ave.	G St.	II	0.87	\$43,500
Rialto Ave	Pepper Ave	Mt Vernon Ave	II	2.25	112,500
San Bernardino Ave.	Tippecanoe Ave.	Mountain View Ave.	III	0.91	\$13,650
San Timoteo Creek Trail	Redlands Blvd	Santa Ana River Trail	I	0.66	660,000
Sand Canyon Trail	Piedmont Dr.	Mid City Connector	I	4.28	\$4,280,000
Santa Ana River Trail	Waterman Ave.	Mountain View Ave.	I	2.28	\$2,280,000
Sterling Ave	Citrus St	.9m N Date St	II	0.10	5,000
Sterling Ave	Marshall Blvd	Lynwood Dr.	II	0.18	9,000
Sterling Ave	SR-210	Highland Ave	II	0.18	9,000
Tippecanoe Ave.	Baseline Rd.	I-10/S City Limit	II	3.92	\$196,000
University Ave.	Varsity Ave.	Cajon Blvd.	II	0.71	\$35,500
Valencia Ave.	30th St.	Highland Ave.	II	0.65	\$32,500
Waterman Ave.	Monterey Ave.	4th St.	II	0.06	\$3,000
Waterman Ave.	Ward St.	5th St.	II	0.06	\$3,000
			<b>Total</b>	<b>103.7</b>	<b>\$47,818,700</b>

Table 5.110

Priority Improvements

Street/Path	From	To	Class	Length (mi.)	Cost Estimate
G St.	Inland Center Dr.	Rialto Ave.	II	0.95	\$47,500
Rialto Ave.	G St.	E St.	II	0.25	\$12,500
Santa Ana River Trail	Waterman Ave.	Mountain View Ave.	I	2.29	\$2,290,000
			<b>Total</b>	<b>3.49</b>	<b>\$2,350,000</b>

**Municipal Code**

The municipal code for the City of San Bernardino does not currently include the mandatory requirement for the inclusion of non-motorized serving infrastructure as part of the site design or development process.

**End of Trip Facilities**

The City of San Bernardino has bike racks dispersed throughout the City, typically at retail centers, schools and multi-unit housing complexes. The City also has a series of bike lockers located at the San Bernardino Metrolink Station.

**Multimodal Connectivity**

Table 5.111

Multimodal Connections

Facility	Facility Type	Facility Location
San Bernardino Metrolink Station	Train Station	3 <sup>rd</sup> St.
Fourth St. Transit Mall	Bus Transfer Center	4 <sup>th</sup> St. and G St.
Crossroads Church PNR	Ride Share Lot	3012 N. Waterman Ave
City-wide Bus Stops	Bus Stops	Throughout City

## Collisions Involving Bicyclists

Table 5.112

### Data for Collisions Involving Bicyclists

Parameter	Collision Rate
Total # of Bicycle Collisions from 2005-2009	152
Total # of Bicycle Fatalities from 2005-2009	3
Average # of Bicycle Collisions Per Year	30.4
Average Bicycle Collision Rate per 1000/year <sup>1</sup>	0.15

Notes:

1. Rate is calculated using SWITRS collision data and population figures by the California Department of Finance

## Safety and Education Programs

The City of San Bernardino does not currently participate in any bicycle safety or education programs.

# City of Twentynine Palms

## Population

27,046

## City Overview

The City of Twentynine Palms, encompassing 78.4 square miles, is located in the Morongo Basin which forms the southwestern corner of the Mojave Desert. This basin includes Joshua Tree National Park and the Marine Corps Air Ground Combat Center (MCAGCC) to the north, which visitors pass through Twentynine Palms to reach. The Mojave Desert is separated from the Sonoran Desert to the south by the Little San Bernardino and Eagle Mountains, which are extensions of the Transverse Ranges. The western Mojave Desert is a flat, sparsely vegetated region that is interspersed with mountain ranges and dry lakes. The area is part of the high desert, large portions of which are at elevations between 2,500 and 4,000 feet above mean sea level.

## Land Use

Twentynine Palms has historically been a rural desert residential community. The area's original inhabitants were the Serrano and Chemehuevi Indians, followed by gold miners, then World War I veterans, who were the first modern settlers of the City in the 1920s.

Development in Twentynine Palms has consisted primarily of residential development, mostly within the central core of the City. In recent years, there has been an increase in the amount of commercial development in the City, most focused along Twentynine Palms Highway, west of Downtown. Conversely, there has been limited industrial development in the City.

## Existing Conditions:

Twentynine Palms' non-motorized bicycle network has expanded significantly since the last update to the Non-Motorized Transportation Plan. The City contains several sections of Class I bikeway along Mesquite Springs Rd and Two Mile Road for a total of 2.50 miles.

The City has also constructed one approximately 4 mile stretch of Class II bike lane along Utah Trail from State Route 62 to the entrance of the Joshua Tree National Park. In total, the City of Twentynine Palms has constructed 9.79 miles of Class I, 7.80 miles of Class II and 0.25 miles of Class III facilities.



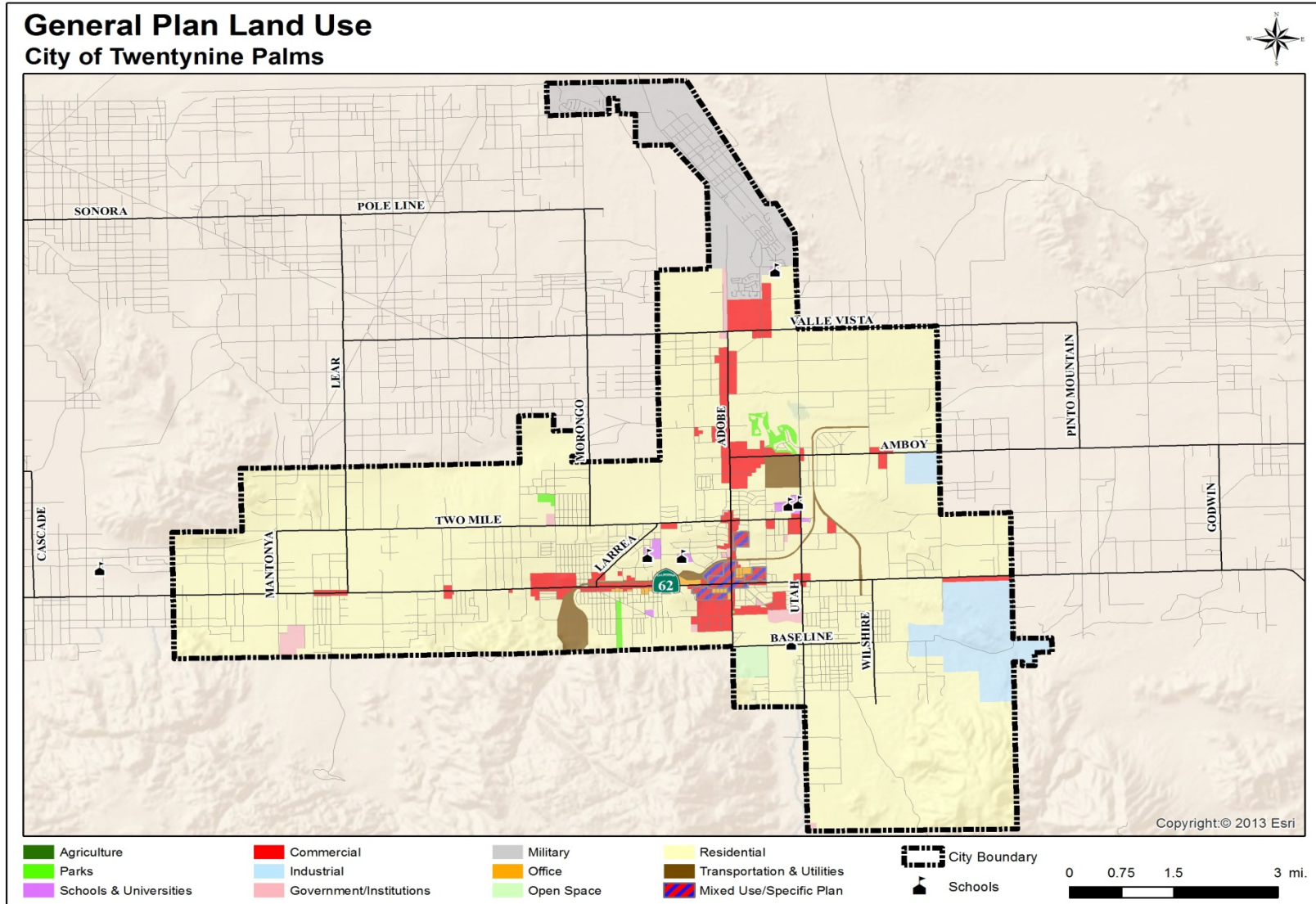

Figure 5.39

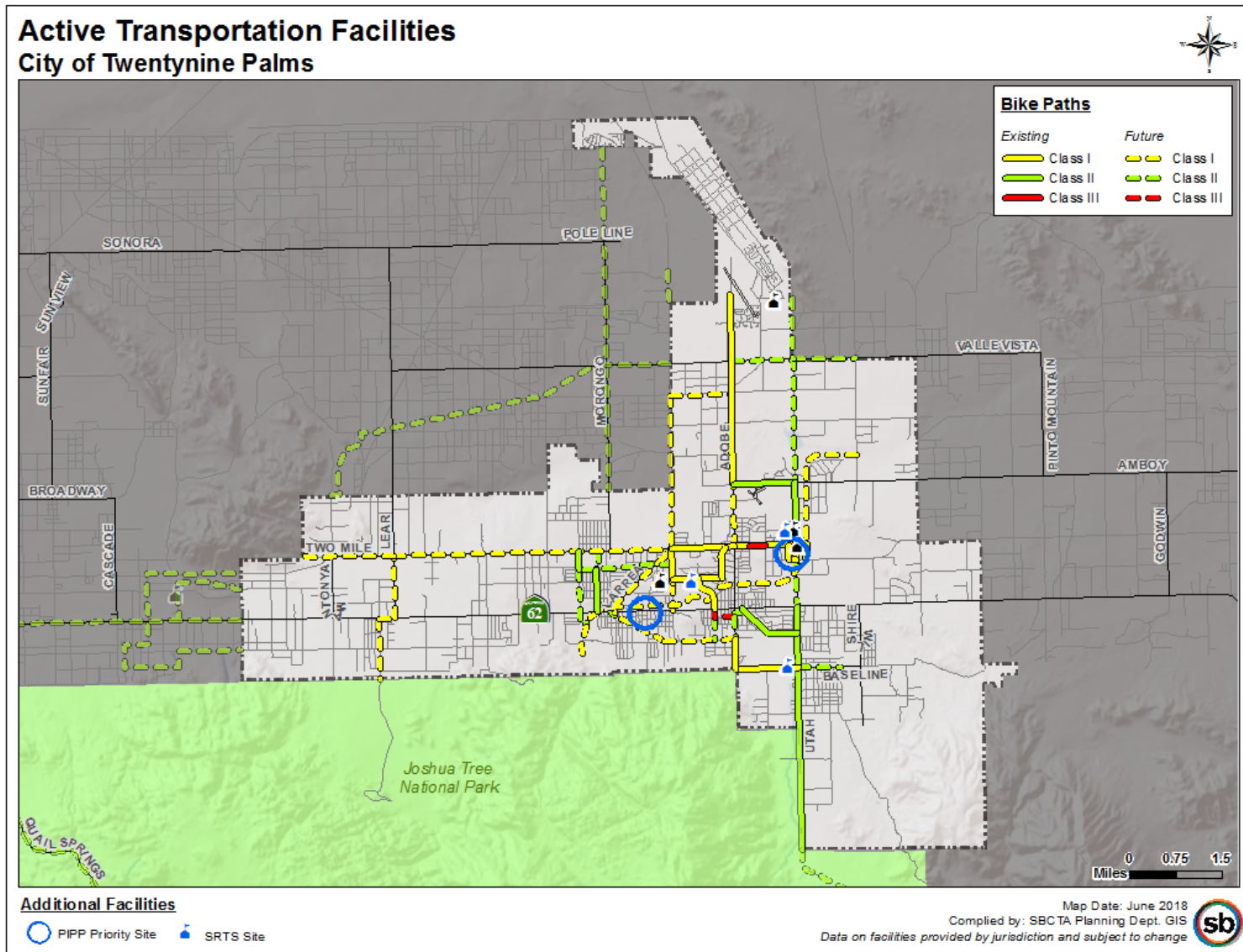

Figure 5.40

Table 5.113

Twentynine Palms Existing Conditions

Street/Path	From	To	Class	Length (mi.)	Cost Estimate
Adobe Rd. Bicycle Path	Sullivan Rd.	Baseline Rd.	I	0.50	\$500,000
Amboy Rd.	Utah Trail	Adobe Rd.	II	1.00	\$50,000
Collins Memorial Bicycle Path	MCAGCC	Amboy Rd.	I	3.09	\$3,090,000
Bagley Avenue Bicycle Trail	El Paseo Rd.	Two Mile Rd.	I	0.54	\$540,000
Baseline Rd. Bicycle Path	Utah Trail	Adobe Rd.	I	1.02	\$1,020,000
El Paseo Drive Bicycle Path	Bagley Ave.	Mesquite Springs Rd.	I	0.80	\$800,000
Encelia Ave.	Two Mile Rd.	Sunnyslope Dr.	II	0.30	\$15,000
Luckie Park Bicycle Trail	Luckie Ave.	Utah Trail	I	0.12	\$120,000
Luckie Park Bicycle Trail	Two Mile Rd.	Joe Davis Dr.	I	0.24	\$240,000
Lupine Ave.	Sunnyslope Dr.	SR-62/Twentynine Palms Hwy	II	0.68	\$34,000
Mesquite Springs Rd.	Two Mile Rd.	Wildcat Way	I	0.57	\$570,000
National Park Drive Bicycle Path	Cactus Dr.	Utah Trail	II	1.48	\$74,000
Split Rock Ave. Bicycle Path	SR-62	El Paseo Rd.	I	0.61	\$610,000
Two Mile Rd.	Mesquite Springs Rd.	Adobe Rd.	I	0.93	\$930,000
Two Mile Rd.	Adobe Rd.	Aztec Ave.	I	0.25	\$250,000
Two Mile Rd.	Aztec Ave.	Desert Knoll Dr.	III	0.25	\$3,750
Two Mile Rd.	Desert Knoll Dr.	Utah Trail	I	0.50	\$500,000
Utah Trail	SR-62	Joshua Tree Guard Shack	II	3.96	\$198,000
Utah Trail	Aztec Ave.	Amboy Rd.	II	0.25	\$12,500
Utah Trail Bicycle Path	Aztec Ave.	Joe Davis Dr.	I	0.62	\$620,000
			<b>Total</b>	<b>17.71</b>	<b>\$10,177,250</b>

*Past Investment in Non-Motorized Infrastructure*

The improvements included in Table 5.113 above constitute a significant investment into the non-motorized transportation infrastructure of Twentynine Palms. Based on planning level estimates, the value of the improvements implemented throughout the City is \$10,177,250.

**Proposed Improvements**

Future improvements to the non-motorized network for the City of Twentynine Palms will continue along the major transportation corridors throughout the City. All future improvements focus on further development of additional Class I and II facilities. A table of future improvements is included in below Table 5.114.

The City of Twentynine Palms has identified several priority improvements, listed below in Table 5.115. When complete, the City will have constructed an additional 33.13 miles of Class I, Class II, and Class III providing internal connectivity to the residents of Twentynine Palms and establishing connections to the roadway networks of the unincorporated Morongo Basin and state highway system.

Table 5.114

Twentynine Palms Future Improvements

Street/Path	From	To	Class	Length (mi.)	Cost Estimate
Adobe Rd.	Amboy Rd.	Two Mile Rd.	I	1.00	\$1,000,000
Adobe Rd. Bicycle Path	Sullivan Rd.	Cactus Dr.	II	0.37	\$18,500
Baseline Road Bicycle Path	Utah Trail	Bedouin Ave.	II	0.69	\$34,500
Cactus Dr. Bicycle Path	Adobe Rd. at Cactus Dr.	National Park Dr.	II	0.26	\$13,000
Cactus Dr. Bicycle Path	Adobe Rd.	SR-62 at Split Rock Ave.	III	0.47	\$7,050
Encelia Ave.	Sunnyslope Dr.	Flood Channel Bicycle Path	II	0.96	\$48,000
Flood Channel Bicycle Path	Bagdad Hwy	Twentynine Palms Hwy	I	6.13	\$6,130,000
Flood Channel Bicycle Path	Twentynine Palms Hwy	0.37mi N/O S City Limit	I	0.78	\$780,000
Hatch Rd. Bicycle Path	Manzanita Ave.	Stardune Ave.	I	0.96	\$960,000
Indian Cove Bicycle Path – Frontage Rd.	Indian Cove Rd.	Lear Ave.	I	0.27	\$270,000
Indian Cove Bicycle Path	SR-62	S City Limit	I	0.99	\$990,000
Indian Trail Bicycle Path	Adobe Rd.	Bullion Ave.	I	1.00	\$1,000,000
Larrea Ave. Bicycle Path	Two Mile Rd.	SR-62	I	1.36	\$1,360,000
Lear Avenue Bicycle Path	Two Mile Rd.	SR-62/Twentynine Palms	I	1.00	\$1,000,000
Lupine Ave.	Two Mile Rd.	Sunnyslope Dr.	II	0.25	\$12,500
Mesquite Springs Rd. Bicycle Path	Indian Trail	Two Mile Rd.	I	2.50	\$2,500,000
Mesquite Springs Rd.	Wild Cat Way	SR-62	I	0.42	\$420,000

Street/Path	From	To	Class	Length (mi.)	Cost Estimate
Split Rock Road – Extended	Cactus Dr.	Sullivan Rd.	II	0.37	\$18,500
Sullivan Rd.	Stardune Ave.	Adobe Rd.	II	1.18	\$59,000
Sunny Slope Drive Bicycle Path	Mesquite Springs Rd.	Encelia Ave.	II	1.52	\$76,000
Two Mile Road Bicycle Path	Utah Trail	Flood Channel Bicycle Path	I	0.18	\$180,000
Two Mile Road – Extended	Lear Ave.	Western City Limit	I	1.45	\$1,450,000
Mesquite Springs Road Bicycle Path	Lear Ave.	Mesquite Springs Rd.	I	4.89	\$4,890,000
Utah Trail	Valle Vista Rd.	Aztec Dr.	II	2.63	\$131,500
Utah Trail Bicycle Path	Joe Davis Rd.	SR-62	II	0.50	\$25,000
Valle Vista Rd.	Adobe Rd.	Utah Trail	II	1.00	\$50,000
			<b>Total</b>	<b>33.13</b>	<b>\$23,423,550</b>

Table 5.115

Priority Improvements

Street/Path	From	To	Class	Length (mi.)	Cost Estimate
Amboy Rd.	Utah Trail	Adobe Rd.	II	1.00	\$50,000
Larrea Ave.	Two Mile Rd.	SR-62	II	1.36	\$68,000
Lupine Ave.	Two Mile Rd.	Sunnyslope Dr.	II	0.25	\$12,500
Mesquite Springs Rd.	Wild Cat Way	SR-62	I	0.42	\$420,000
Utah Trail	Joe Davis Rd.	SR-62	II	0.50	\$25,000
			<b>Total</b>	<b>3.53</b>	<b>\$575,500</b>

**Pedestrian Facilities**

The City has also identified opportunities to enhance pedestrian facilities. These are described in the 2017 *SBCTA Safe Routes to School Plan (SRTS)* and in the 2017 *SBCTA Points of Interest Pedestrian Plan (PIPP)*. The *SRTS* focuses on improving access to neighborhood schools listed in Table 5.116, while the *PIPP* focuses on improving access to other community assets listed in Table 5.117. Specific improvement recommendations per project are detailed in the *SRTS Plan Phase II – Volume 2* for items in Table 5.116 and the *PIPP* for items in Table 5.117.

Table 5.116  
SRTS Opportunities

Project	Potential Connection to Bikeways, by Status and Class, within ¼ Mile of Project	Number of Improvements Identified	Cost Estimate
Palm Vista E.S	Existing & Planned Class II	8	\$640,366
Oasis E.S.	Existing Class I, II	6	\$1,022,370
Twentynine Palms E.S.	Planned Class II	10	\$722,815
<b>Total</b>		<b>24</b>	<b>\$2,385,551</b>

Table 5.117  
PIPP Opportunities

Project	Potential Connection to Bikeways, by Status and Class, within ¼ Mile of Project	Proposed Project Ranking
Luckie Park and Twentynine Palms Junior H.S.	Existing Class I, II	1
Holiday Inn Express & Suites	Planned Class II	2
Twentynine Palms H.S.	Planned Class II	NR <sup>A</sup>
Knott Sky Park	Planned Class II	NR <sup>A</sup>

TABLE NOTES – <sup>A</sup>: NR = “Not Ranked”, listed as potential project locations

### Municipal Code

Although the municipal code for the City of Twentynine Palms does not currently include the mandatory requirement for the inclusion of non-motorized transportation serving infrastructure as part of the site design process, such standards are being considered for inclusion within the update to the City’s General Plan and may be included within the update to the City’s Development Code.

### End of Trip Facilities

The City of Twentynine Palms has bike racks dispersed throughout the City, typically at retail centers, schools and multi-unit housing complexes.



**Multimodal Connectivity**

Table 5.118

Location of Multi-Modal Connections

Facility	Facility Type	Facility Location
Twentynine Palms Transit Center	Bus Transfer Center	Adobe & Cactus
City-wide Bus Stops	Bus Stops	Throughout City

**Collisions Involving Bicyclists**

Table 5.119

Data for Collisions Involving Bicyclists

Parameter	Collision Rate
Total # of Bicycle Collisions from 2012-2016	2
Total # of Bicycle Fatalities from 2012-2016	0
Total # of Bicycle Injuries from 2012-2016	2
Average # of Bicycle Collisions Per Year	0.4
Average Bicycle Collision Rate per 1000/year <sup>1</sup>	0.01

Notes:

1. Rate is calculated using SWITRS collision data and population figures by the California Department of Finance

**Safety and Education Programs**

The City of Twentynine Palms does not currently participate in any bicycle safety or education programs.

## City of Upland

### Population

73,957

### City Overview

The City of Upland was incorporated on May 15, 1906, after previously being named North Ontario. The City was originally established as an irrigation colony by George and William Chaffey. Upland is located approximately 35 miles west of Los Angeles and immediately below the San Gabriel mountain range. The City provides a gateway to the Los Angeles National Forest and the Mount Baldy recreational area.

### Land Use

The northern portion of the City is mostly low-density residential. The steep hillsides leading up to the San Gabriel mountain range make it less appropriate for commercial or industrial development. Most of the existing retail, industrial and office development is located adjacent to the I-10 and SR-210 freeways and the historic Route 66/Foothill Boulevard.

The city has a small downtown area, which is generally bounded by Euclid Ave to the west, Campus Avenue to the east, Arrow Highway to the north and 8<sup>th</sup> Street to the south. A significant port of the City's future development is planned to be concentrated in this area as it is close in proximity to the Metrolink station and the I-10 freeway. The City is currently developing an updated Downtown Specific Plan.

### Existing Conditions:

The growth in the City of Upland's non-motorized system has been spread evenly across Class I, II and III facilities. The City now includes 6.33 miles of Class I, 21.43 miles of Class II and 12.19 miles of Class III facilities for a total of 39.41 miles. Since the last update to the Non-Motorized Transportation Plan, the City has averaged 4 miles of new infrastructure per year.

#### *Growth/Past investment in system*

The improvements included in Table 5.120 constitute a significant investment into the non-motorized transportation infrastructure of Upland. Based on planning level estimates, the value of the improvements implemented throughout the City is \$7,584,350.

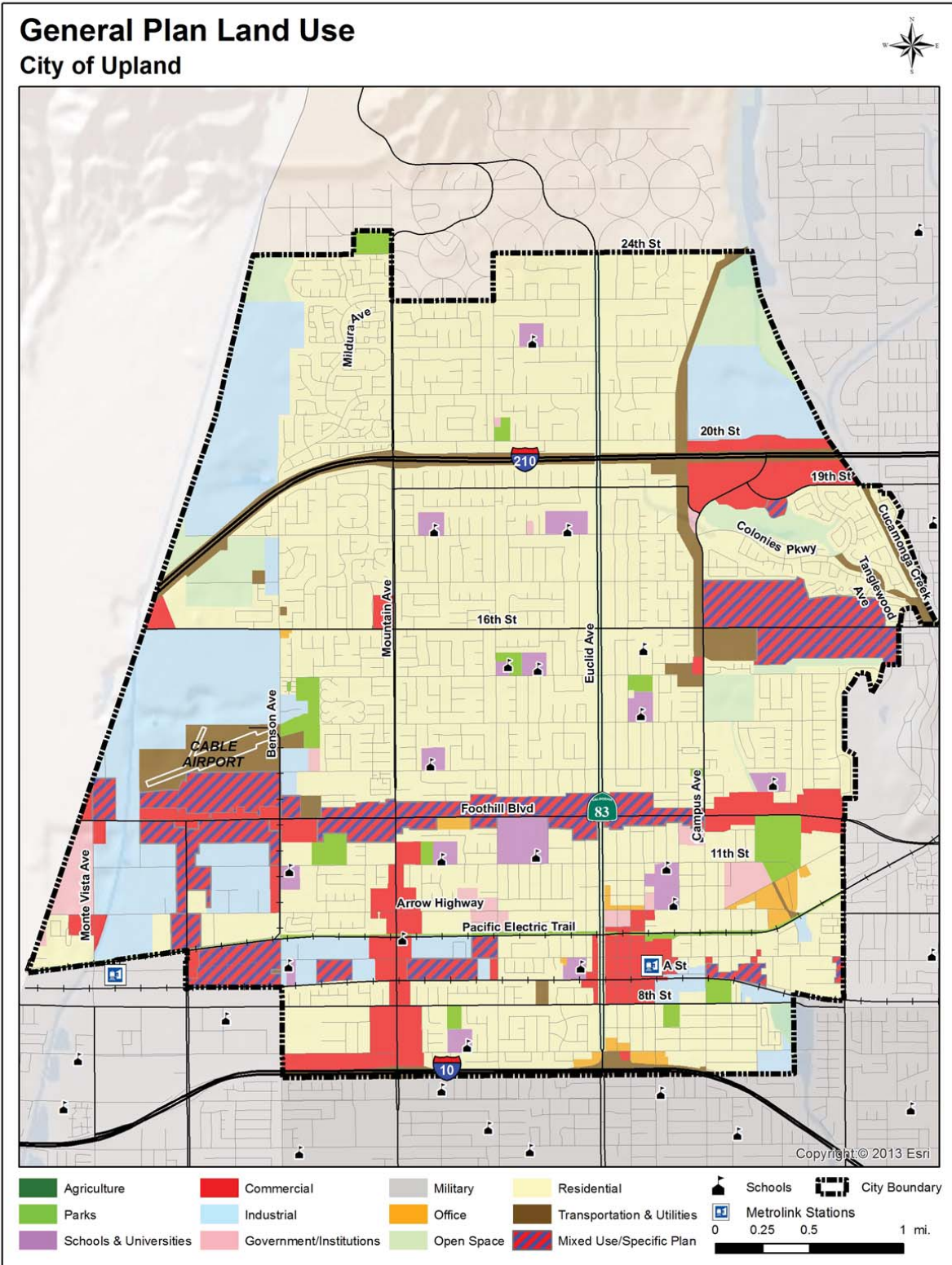

Figure 5.42

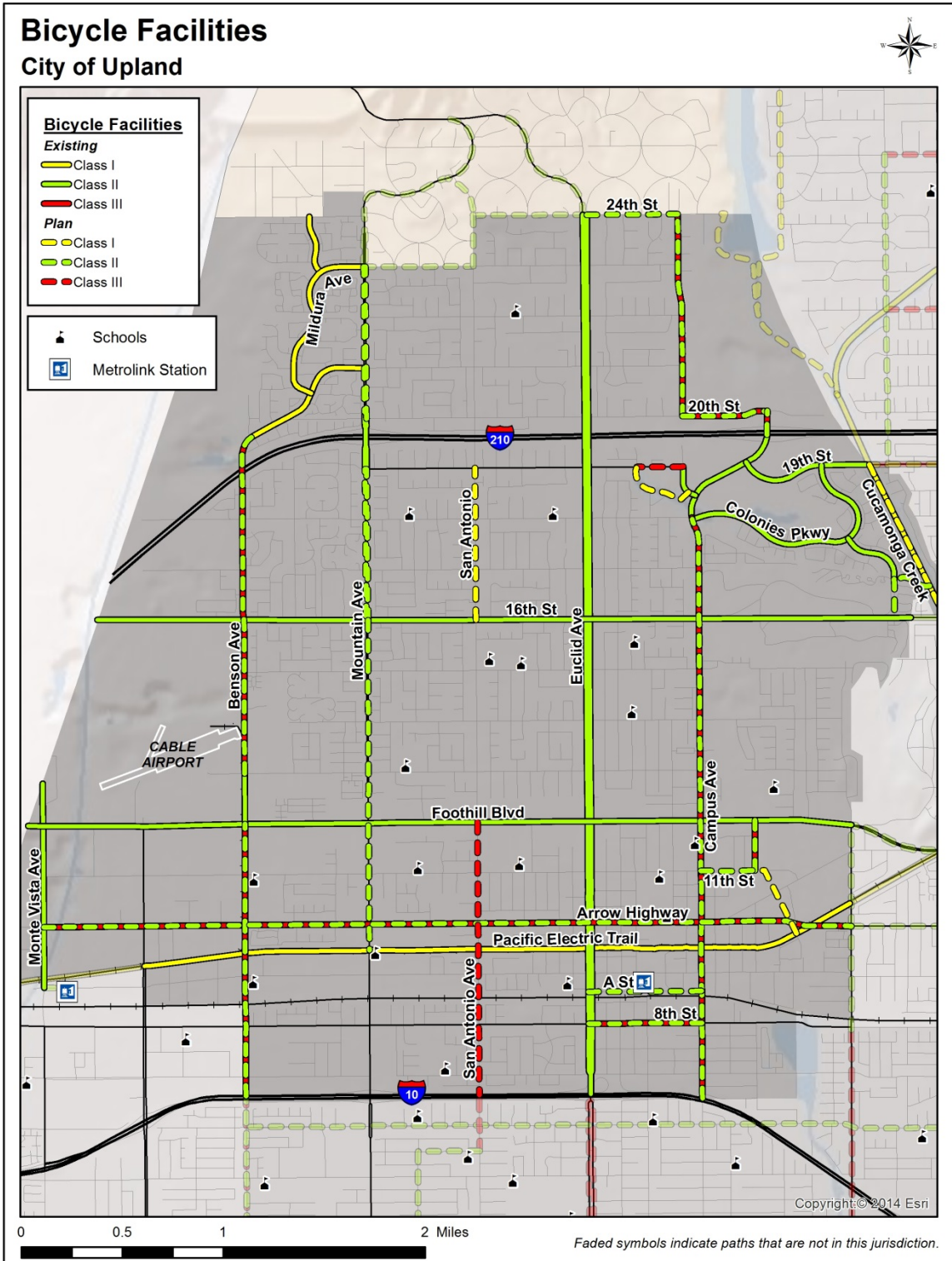

Figure 5.43

Table 5.120  
Upland Existing Conditions

Street/Path	From	To	Class	Length (mi.)	Cost Estimate
8th St.	Euclid Ave.	Campus Ave.	III	0.54	\$8,100
16th St.	SR-210	E City Limit	II	4.03	\$201,500
19th St.	850' w/o Campus Ave.	Campus Ave.	II	0.16	\$8,000
19th St.	Campus Ave.	Cucamonga Creek	II	0.65	\$32,500
20th St.	Campus Ave.	Campus Ave.	III	0.42	\$6,300
Arrow Highway	Monte Vista Ave.	Grove Ave.	III	4.00	\$60,000
Benson Ave.	13th St.	Foothill Blvd.	II	0.25	\$12,500
Benson Ave.	Birkdale Ave.	13th St.	III	1.68	\$25,200
Benson Ave.	Foothill Blvd.	I-10	III	1.35	\$20,250
Benson Ave.	Mountain Ave.	Birkdale Ave.	I	0.71	\$710,000
Campus Ave.	18th St.	I-10	III	2.88	\$43,200
Campus Ave.	20th St.	SR-210	III	0.07	\$1,050
Campus Ave.	24th St.	20th St.	III	1.00	\$15,000
Campus Ave.	SR-210	18th St.	II	0.60	\$30,000
Colonies Pkwy.	Campus Ave.	19th St.	II	1.28	\$64,000
Cucamonga Creek	19th St.	Baseline Rd.	I	0.85	\$850,000
Deakin Ave.	24th St.	Mildura Ave.	I	0.29	\$290,000
Euclid Ave.	24th St.	I-10	II	8.61	\$430,500
Foothill Blvd.	W City Limit	Grove Ave.	II	4.08	\$204,000
Hospital Pkwy.	Foothill Blvd.	11th St.	III	0.25	\$3,750
Mildura Ave.	Mountain Ave.	Benson Ave.	I	0.92	\$920,000
Monte Vista Ave.	N City Limit	Richton St.	II	1.01	\$50,500
Mountain Ave.	20th St.	19th St.	II	0.42	\$21,000
Pacific Electric Trail	W. City Limit	E City Limit	I	3.56	\$3,560,000
Tanglewood Ave.	Colonies Pkwy.	Golf Club Dr.	II	0.34	\$17,000
			<b>Total</b>	<b>39.95</b>	<b>\$7,584,350</b>

Table 5.121  
Upland Future Improvements

Street/Path	From	To	Class	Length (mi.)	Cost Estimate
8th St.	Euclid Ave.	Campus Ave.	II	0.54	\$27,000
11th St.	Campus Ave.	Hospitality Pkwy.	II	0.26	\$13,000
19th St.	3 <sup>rd</sup> St.	820' e/o Francis Ave.	III	0.22	\$3,500
20th St.	Campus Ave.	Campus Ave.	II	0.42	\$21,000
24th St.	Euclid Ave.	Campus Ave.	II	0.45	\$22,500
A St.	Euclid Ave.	Campus Ave.	II	0.56	\$28,000
Arrow Highway	Monte Vista Ave.	Grove Ave.	II	4.00	\$200,000
Benson Ave.	Birkdale Ave.	13th St.	II	1.68	\$84,000
Benson Ave.	Foothill Blvd.	I-10	II	1.35	\$67,500
Campus Ave.	18th St.	I-10	II	2.87	\$143,500
Campus Ave.	20th St.	SR-210	II	0.11	\$3,500
Campus Ave.	24th St.	20th St.	II	1.00	\$50,000



Cucamonga Creek Safety Enhancements	9th St.	Baseline Rd.	I	0.84	\$840,000
Hospital Pkwy.	Foothill Blvd.	11th St.	II	0.25	\$12,500
Hospitality Pkwy. Trail	11 <sup>th</sup> St.	Pacific Electric Trail	I	0.39	\$400,000
Hummingbird Ln.	Tanglewood Ave.	Cucamonga Creek Trail	II	0.18	\$9,000
Mountain Ave.	16th St.	Pacific Electric Trail	II	1.64	\$81,750
Mountain Ave.	19th ST.	16th St.	II	0.74	\$37,000
Mountain Ave.	21st St.	20th St.	II	0.75	\$37,500
San Antonio Ave.	Foothill Blvd.	S. City Limit	III	1.37	\$68,500
San Antonio Ave.	Baseline St.	19th St.	I	1.47	\$1,478,210
Station 4 Trail	19 <sup>th</sup> /3 <sup>rd</sup> St.	19 <sup>th</sup> St.	I	0.36	\$360,000
Tanglewood Ave.	Golf Club Dr./Hummingbird Ln.	16th St.	II	0.19	\$9,500
			<b>Total</b>	<b>21.64</b>	<b>\$3,997,460</b>

### Proposed Improvements

The future improvements identified by the City of Upland will upgrade the existing Class III facilities to Class II standards. When complete, the City will have upgraded a total of 12.19 miles of Class III infrastructure to Class II standards, improving the safety to cyclists and reinforcing their place on the City's arterial system.

The City of Upland has identified elements of safety enhancement on the Class I Cucamonga Creek Trail. Improvements will be prioritized by the City Council in the future, possibly as part of the City's General Plan update.

Table 5.122

### Priority Improvements

Street/Path	From	To	Class	Length (mi.)	Cost Estimate
8 <sup>th</sup> St.	Euclid Ave.	Campus Ave.	II	0.54	\$27,000
Campus Ave.	18 <sup>th</sup> St.	I-10	II	2.87	\$143,500
Cucamonga Creek Safety Enhancements	9 <sup>th</sup> St.	Baseline Rd.	I	0.84	\$840,000
Hospitality Pkwy Trail	11 <sup>th</sup> St.	Pacific Electric Trail	I	0.39	\$400,000
San Antonio Ave.	Foothill Blvd.	S. City Limit	III	1.37	\$68,500
			<b>Total</b>	<b>6.01</b>	<b>\$1,479,000</b>

### Municipal Code

The City of Upland Municipal Code - 17.22.090 Vehicle trip reduction measures – provides for the following related to non-motorized transportation:



- A. Purpose. The purpose of this section is to promote the use of methods of transportation which are alternatives to the single occupant vehicle. These alternative methods are to be provided for in new development so as to meet congestion management and air quality goals at minimal cost and disruption to citizens, business and industry.
- B. Applicability. Vehicle trip reduction measures shall apply to all new residential and nonresidential development which exceed the thresholds described in subsections (B) (1) through (3) of this section inclusive. Such measures shall be integrated into the existing development review process of the administrative committee and implemented as follows:
1. Multifamily Residential Projects Containing Ten or More Units.
    - a. Bicycle parking facilities such as a bicycle rack or lockers shall be provided at a rate of one per 30 vehicle parking spaces with at least one three-bike rack.
    - b. On-site pedestrian walkways and bicycle facilities to connect each building in a complex to public streets.
    - c. Passenger loading area located close to building entrance(s) shall be provided for projects with 100 or more parking spaces. The loading areas shall spatially be the equivalent to a minimum of five parking spaces.
    - d. Transit improvements such as bus pullouts, bus pads, and bus shelters as determined to be appropriate by the administrative committee in cooperation with Omnitrans.
  2. Single-Family Residential Projects Containing 500 or More Units. A telecommuting center shall be developed or contributions toward development of such a center on site shall be made to the reasonable satisfaction of the community development director.
  3. Nonresidential Projects.
    - a. Bicycle parking facilities such as bicycle racks or lockers shall be provided at a rate of one per 30-vehicle parking spaces with at least one bicycle rack capable of holding three bicycles.
    - b. On-site pedestrian walkways and bicycle facilities to connect each building in a complex to public streets.
    - c. Passenger loading area located close to building entrance(s) shall be provided for projects with 100 or more parking spaces. The loading areas shall spatially be the equivalent to a minimum of five parking spaces.
    - d. A minimum of one shower facility for persons walking or bicycling to work for each project which meets the following thresholds:

Commercial	250,000 square feet
Industrial	325,000 square feet
Office	125,000 square feet
Hotels and motels	250 rooms

**End of Trip Facilities**

The City of Upland has bike racks dispersed throughout the City, typically at retail centers, schools and multi-unit housing complexes.

**Multimodal Connectivity**

Table 5.123

Location of Multi-Modal Connections

Facility	Facility Type	Facility Location
Upland Metrolink Station	Train Station	Downtown Upland
City-wide Bus Stops	Bus Stops	Throughout City

**Collisions Involving Bicyclists**

Table 5.124

Data for Collisions Involving Bicyclists

Parameter	Collision Rate
Total # of Bicycle Collisions from 2005-2009	96
Total # of Bicycle Fatalities from 2005-2009	1
Average # of Bicycle Collisions Per Year	19.2
Average Bicycle Collision Rate per 1000/year <sup>1</sup>	0.26

Notes:

1. Rate is calculated using SWITRS collision data and population figures by the California Department of Finance

**Safety and Education Programs**

The City of Upland does not currently participate in any bicycle safety or education programs, but the City does work closely with the Upland Unified School District in its Safe Routes to School Program.

## City of Victorville

### Population

123,701

### City Overview

Incorporated as a general law city in September 21, 1962, Victorville began its transition to a modern day community in about 1885, known then as the “Town of Victor” after Jacob Nash Victor, a construction superintendent for the California Southern Railroad (Santa Fe Railroad).

The City of Victorville is located in southwestern San Bernardino County, in the geographic sub-region of the southwestern Mojave Desert known as the Victor Valley and commonly referred to as the "High Desert" due to its approximate elevation of 2,900 feet above sea level. The Victor Valley is separated from other urbanized areas in Southern California by the San Bernardino and San Gabriel mountains.

### Land Use

The City’s general plan provides for a wide variety of residential land use designations which provides a broad range of dwelling unit densities and allows for a diversity of housing unit types. Residential designations include: Very Low Residential, Low Density Residential, Medium Density Residential, High Density Residential, Mixed Density, and Mixed-Use Density.

The City of Victorville has historically been and continues to be the primary commerce center of the Victor Valley. The City’s general plan provides for a wide variety of businesses to locate or expand in the City. Designated business categories include both commercial and industrial, and consist of the following: Commercial, Office Professional, Light Industrial and Heavy Industrial. The Mixed-Use High Density designation allows for business components, including retail, office and civic.

The map in Figure 5.35 page shows the General Plan land use designations for the City of Victorville.

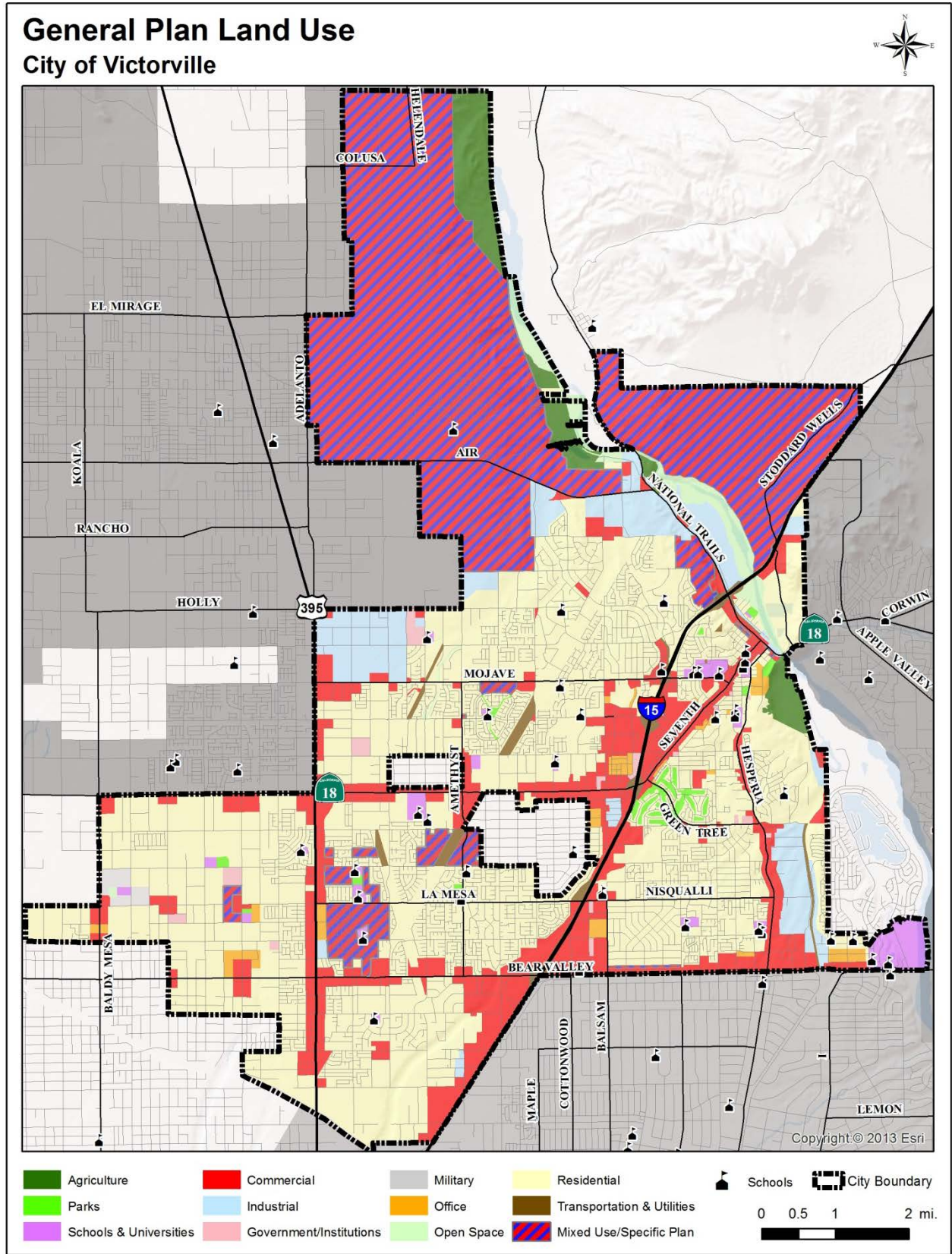
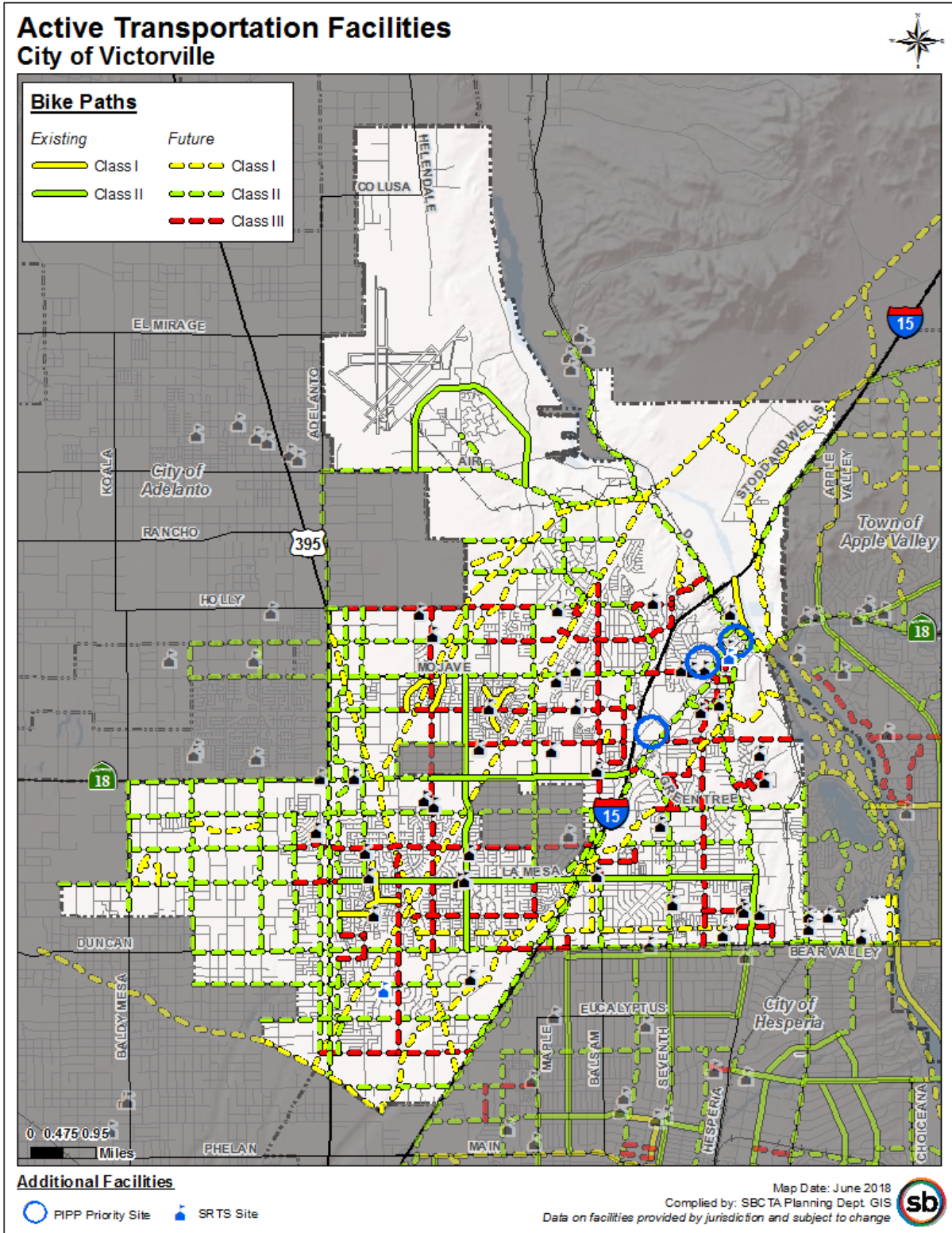

Figure 5.44





C:\Users\christopher\Documents\Projects\BikePlan\_Feb16start\DataDrivenMaps\ATP\_Portrait.mxd

Figure 5.45

**Existing Conditions:**

The City of Victorville has constructed one demonstration segment of the Mojave Riverwalk Class I facility. The City is also in the process of the preparing the environmental document for the remainder of the project. Ultimately, the Riverwalk will connect northern Victorville to the Victor Valley Community College when completed.

In addition to the work on Mojave Riverwalk, the City prepared a focused non-motorized plan, which was adopted by the City Council in June 2010.

Table 5.125

Victorville Existing Conditions

Street/Path	From	To	Class	Length (mi.)	Cost Estimate
Amethyst Rd.	La Mesa Rd.	Bear Valley Rd.	II	1.00	\$50,000
Amethyst Rd.	Mojave Dr.	La Mesa Rd.	II	3.00	\$150,000
La Mesa Rd.	I-15 Bridge	Cantina Dr.	III	0.64	\$9,600
Hesperia Rd.	Bear Valley Rd.	Nisqualli Rd.	II <sup>A</sup>	1.01	\$50,500
Nisqualli Rd.	Hesperia Rd.	I-15 Bridge	II	2.60	\$130,000
Mojave Riverwalk	I-15	6th St.	I	0.83	\$830,000
Palmdale Rd.	I-15	Cobalt Rd.	II	2.89	\$144,500
Paseos	La Mesa Rd.	Cantina Rd.	I	1.44	\$1,440,000
Paseos	Mojave Dr.	Hook Blvd	I	0.55	\$550,000
Paseos	Mojave Dr.	Seneca Rd.	I	1.20	\$1,200,000
Paseos	Power Line Corridor 1	Hook Blvd	I	0.60	\$600,000
Phantom Loop	Air Expressway	Air Expressway	II	3.65	\$182,500
			<b>Total</b>	<b>19.41</b>	<b>\$5,337,100</b>

TABLE NOTES – <sup>A</sup>: Listed in local plan as Class II Striped

*Growth/Past investment in system*

Since the San Bernardino County Non-Motorized Transportation Plan was first prepared in 2001, the City of Victorville has constructed 19.41 miles of Class I facilities at a rate of 1.21 miles per year.

*Past Investment in Non-Motorized Infrastructure*

The improvements included in Table 5.125 above constitute a significant investment into the non-motorized transportation infrastructure of Victorville. Based on planning level estimates, the value of the improvements implemented throughout the City is \$5,337,100.



## Proposed Improvements

Future improvements to the non-motorized network for the City of Victorville will continue along the major transportation corridors throughout the City. All future improvements focus on further development of additional Class II facilities. A table of future improvements is included in Table 5.126 below. When complete, the City will have constructed an additional 60.03 miles of Class I, 120.62 miles of Class II, and 50.86 miles of Class III, providing additional internal connectivity to the residents of Victorville and increased connectivity to communities in the High Desert.

Table 5.126

### Victorville Proposed Improvements

Street/Path	From	To	Class	Length (mi.)	Cost Estimate
Air Expressway	Adelanto Rd.	National Trails Hwy.	II	4.82	\$241,000
Amargosa Rd.	Yates Rd.	Power Line Corridor 1	III	3.33	\$49,950
Amethyst Rd.	Mojave Dr.	Hopland Dr.	II	1.00	\$50,000
Apatite Ave.	Power Line Easement	Bear Valley Rd.	III	0.27	\$4,050
Arrowhead Dr.	Green Tree Blvd.	Nisqualli Rd.	II	1.10	\$16,500
Arrowhead Dr.	Green Tree Blvd.	Pebble Beach Park	III	1.10	\$16,500
Baldy Mesa Rd.	Olivine Rd.	Palmdale Rd.	II	2.00	\$100,000
Balsam Rd.	Nisqualli Rd.	Bear Valley Rd.	II	1.00	\$50,000
Balsam Rd.	Nisqualli Rd.	Winona St.	III	0.25	\$3,750
Bear Valley Rd.	Western City Limits	Oro Grande Wash	II <sup>A</sup>	4.49	\$224,500
Bear Valley Rd.	Apatite Ln	Eastern City Limits	II <sup>A</sup>	1.51	\$75,500
Bear Valley Rd.	Fish Hatchery Rd.	Jacaranda Ave.	I	0.30	\$300,000
Bear Valley Rd.	Oro Grande Wash	Cottonwood Ave.	III	0.97	\$14,550
Bellflower St.	Bear Valley Rd.	Palmdale Rd.	II	2.50	\$125,000
Cactus Rd.	Power Line Corridor 2	Whitecap Way	II	2.19	\$109,500
California Aqueduct	Southern City Limit at Solano Rd.	Oro Grande River Trail	I	2.02	\$2,020,000
Cantina Rd.	Honeybear Ln.	Hopland St.	II	5.09	\$254,500
Civic Dr.	Amargosa Rd.	Roy Rogers Dr.	III	1.17	\$17,550
Civic Dr.	Roy Rogers Dr.	Mojave Dr.	II	0.52	\$26,000
Clovis St.	Western City Limits	Power Line Corridor 1	II	2.01	\$100,500
Cobalt Rd.	Bear Valley Rd.	Hopland St.	III	5.01	\$75,150
Cottonwood Ave.	Bear Valley Rd.	Power Line Easement	III	0.25	\$3,750
Dos Palmas Rd.	Western City Limits	Amargosa Rd.	II	6.90	\$345,000
Eagle Ranch Pkwy/Mesa Linda St.	Honeybear Ln.	Sequoia St.	III	0.35	\$5,250
El Rio Rd.	Dos Palmas Rd.	La Mesa Rd.	II	1.16	\$58,000
El Evado Rd.	La Brisa Rd.	La Mesa Rd.	II	0.08	\$4,000
El Evado Rd.	La Mesa Rd.	Hopland St.	II	3.93	\$200,000
El Evado Rd.	Northstar Ave.	La Mesa Rd.	III	0.51	\$7,650
Eucalyptus Rd.	Western City Limits	Eastern City Limits	II	3.37	\$168,500
Forest Ave.	Fourth St.	Hesperia Rd.	II	0.46	\$23,000

Street/Path	From	To	Class	Length (mi.)	Cost Estimate
Fourth St.	Forest Ave.	D St.	II	0.33	\$16,500
George Blvd.	Air Expressway	Nevada Ave.	II	0.59	\$29,500
Green Tree Blvd./Yates Rd.	Seventh St.	Eastern City Limits	II	2.95	\$147,500
Green Tree East Elem Sch.	Hesperia Rd.	Gilbralter Dr. via Baywood Dr.	III	0.82	\$12,300
Hesperia Rd.	Nisqualli Rd.	Verde St.	II <sup>A</sup>	3.01	\$150,500
Hesperia Rd	Verde St.	D St.	II	0.63	\$31,500
Highway 18	Hesperia Rd.	E City Limit	II	0.63	\$31,500
Highway 395	Holly Rd/Hopland St.	Mesa St.	II	6.52	\$326,000
Highway 395	Mesa St.	California Aqueduct	II	0.35	\$17,500
Holly St.	Highway 395	Cantina Rd.	III	0.28	\$4,200
Honeybear Ln.	Eagle Ranch Pkwy	Cantina Rd.	III	0.32	\$4,800
Hook Blvd	Western City Limits	Topaz Rd.	II	1.01	\$50,500
Hook Blvd	Topaz Rd.	I-15	III	3.45	\$51,750
Hopland Rd.	Cantina Rd.	El Evado Rd.	III	2.74	\$41,100
Hopland Rd.	El Evado Rd.	Llanada Ave.	II	0.65	\$35,000
Hopland Rd.	Llanada Ave.	Power Line Corridor 1	III	0.17	\$2,550
Jasmine St.	W/O Hesperia Rd.	Apatitle Ave.	III	0.50	\$7,500
La Mesa Rd.	Western City Limits	Mesa View Rd.	II	3.45	\$172,500
La Mesa Rd.	Mesa View Dr.	Cantina Dr.	III	0.64	\$9,600
Llanada Ave.	Hopland Rd.	Village Dr.	II	0.20	\$10,000
Luna Rd.	Mesa View Dr.	El Rio Rd.	III	4.33	\$64,950
Luna Rd.	Western City Limits	Mesa View Rd.	II	2.43	\$121,500
Mariposa Rd.	Bear Valley Rd.	Palmdale Rd.	II	2.91	\$145,500
Mesa Linda Ave.	La Mesa Rd.	Hopland St.	II	4.00	\$200,000
Mesa St.	Highway 395	Amargosa Rd.	III	2.05	\$30,750
Mesa St.	Pena Rd.	Highway 395	III	0.12	\$1,800
Mesa View Rd.	Bear Valley Rd.	Dos Palmas Rd.	II	2.00	\$100,000
Mojave Dr.	7 <sup>th</sup> St.	Victor St.	II	0.44	\$22,400
Mojave Dr.	Ramada Dr.	Victor St.	II	0.07	\$3,500
Mojave Dr.	Western City Limits	Village Dr.	II	4.63	\$231,500
Mojave Dr.	Village Dr.	Ramada Dr.	III	1.42	\$21,300
Mojave Riverwalk	Yates Rd.	Mojave Narrows Regional Park	I	0.64	\$640,000
Mojave Riverwalk – Phase I	Park Rd. (including Mojave Narrows)	Bear Valley Rd.	I	3.90	\$3,900,000
Mojave Riverwalk – Phase II	4 <sup>th</sup> St. at National Trails Highway	Mojave River Levee	I	0.13	\$140,000
Mojave Riverwalk – Phase II	Forest Ave.	Park Rd.	II	3.74	\$187,050
Mojave Riverwalk – Phase II	National Trails Hwy.	Hesperia Rd.	III	0.68	\$10,250
Mojave Riverwalk – Phase III	6 <sup>th</sup> St.	Mojave Narrows Park	I	2.17	\$2,179,300
Monte Vista Rd.	Bear Valley Rd.	Palmdale Rd.	II	2.50	\$125,000
National Trails Hwy./D St.	Hesperia Rd.	Northern City Limits	II	4.92	\$246,000
Ninth Ave.	Winona St.	Ottawa St.	III	0.25	\$3,750
Northstar Ave.	Power Line Corridor 2	El Evado Rd.	III	1.77	\$26,550

Street/Path	From	To	Class	Length (mi.)	Cost Estimate
Oro Grande River Trail	California Aqueduct	I-15	I	5.08	\$5,080,000
Oro Grande River Trail	I-15	Yates Rd.	I	1.32	\$1,320,000
Oro Grande River Trail	N/O Seneca Dr.	Center Street Park	I	0.48	\$480,000
Oro Grande River Trail	N/O Seneca Dr.	Mojave Riverwalk	I	1.46	\$1,460,000
Oro Grande River Trail	Pebble Beach Park	N/O Seneca Dr.	I	0.84	\$840,000
Ottawa St.	Oro Grande Wash	Hesperia Rd.	II	1.84	\$92,000
Palmdale Rd.	I-15	Seventh St.	III	0.18	\$2,700
Palmdale Rd.	Western City Limits	Cobalt Rd.	II	4.43	\$221,500
Paseos	Baldy Mesa Rd.	E/O Braceo St.	I	1.31	\$1,310,000
Paseos	Clovis St.	Mojave Dr.	I	1.93	\$1,930,000
Paseos	Monte Vista Rd.	Bellflower St.	I	1.05	\$1,050,000
Paseos	Rancho Rd.	Amethyst Rd.	I	0.84	\$840,000
Paseos	Seneca Rd.	Valley Park Ln.	I	0.20	\$200,000
Paseos	Tawny Ridge Ln.	National Trails Highway	I	0.76	\$760,000
Pena Rd.	Mesa St.	Luna Rd.	II	3.03	\$151,500
Power Line Easement	California Aqueduct	Air Expressway	I	9.60	\$9,600,000
Power Line Easement	Electrical Station at Palmdale Rd.	Power Line Corridor 1 at National Trails Hwy	I	6.08	\$6,080,000
Power Line Easement	Hwy 395	I-15	I	6.74	\$6,740,000
Power Line Easement	National Trails Hwy	Northern City Limit	I	2.11	\$2,110,000
Power Line Easement	Power Line Corridor 2	E/O Hesperia Rd.	I	3.98	\$3,980,000
Power Line Easement Connector	Oro Grande River Trail	Power Line Easement at Locust Ave.	I	1.02	\$1,020,000
Power Line Easement Connector	Power Line Easement	Stoddard Wells Rd.	I	1.32	\$1,320,000
Puesta Del Sol Dr.	Village Dr.	Tawny Ridge Ln	III	0.59	\$8,850
Rancho Rd.	Western City Limits	Power Line Corridor 1	II	2.30	\$115,000
Richmond Rd.	Mesa St.	Sequoia St.	II	1.56	\$78,000
Ridgecrest Rd.	Yates Rd.	Bear Valley Rd.	II	2.26	\$33,900
Seneca Rd.	Amethyst Rd.	Civic Dr.	III	2.32	\$34,800
Seneca Rd.	Hesperia Rd.	BNSF Railroad	III	1.02	\$15,300
Seneca Rd.	Seventh St.	Hesperia Rd.	III	0.97	\$14,550
Sequoia St.	Richmond Ave.	Eagle Ranch Pkwy/Mesa Linda St.	III	0.37	\$5,550
Seventh Ave.	Bear Valley Rd.	Nisqualli Rd.	II	1.00	\$50,000
Seventh St.	Green Tree Blvd	Forest Ave.	II <sup>A</sup>	2.14	\$107,000
Silica Dr.	Third Ave.	Hesperia Rd.	III	0.71	\$10,650
Sixth St.	Mojave Dr.	Forest Ave.	II	0.44	\$22,000
Smoke Tree Rd.	California Aqueduct	I-15	II	1.48	\$74,000
Spring Valley Pkwy.	Bear Valley Rd.	Huerta Rd.	II	0.36	\$5,400
Stoddard Wells Rd.	Highway 18	Dante St.	I	2.14	\$2,140,000
Stoddard Wells Rd.	Outer I-15 S	Dante St.	I	2.61	\$2,610,000
Sycamore St.	Western City Limits	Oro Grande Wash	II	4.18	\$209,000
Tawny Ridge Ln.	Whitecap Way	National Trails Hwy	III	3.90	\$58,500

Street/Path	From	To	Class	Length (mi.)	Cost Estimate
Third Ave./Jarvis Rd./Rodeo Dr.	Bear Valley Rd.	Seventh St.	III	3.75	\$56,250
Topaz Rd.	Mesa St.	Power Line Corridor 2	III	2.90	\$43,500
Verde St.	Mojave Dr.	Center St.	II	0.12	\$6,300
Victor St.	7th St.	Mojave Dr.	II	0.43	\$21,800
Village Dr.	Air Expressway	Mojave Dr.	II	3.39	\$50,850
Winona St.	Balsam Rd.	Ninth Ave.	III	0.51	\$7,650
Yates Rd.	Arrowhead Dr.	Green Tree Blvd	III	0.18	\$2,700
Yates Rd.	Oro Grande River Trail	Arrowhead Dr.	III	0.19	\$2,850
Yucca Ave./Center St./Verde St.	Sixth Ave.	Hesperia Rd.	III	0.52	\$7,800
			<b>Total</b>	<b>231.94</b>	<b>\$66,622,950</b>

TABLE NOTES – <sup>^</sup>: Listed in local plan as Class II Striped

Table 5.127

Priority Improvements

Street/Path	From	To	Class	Length (mi.)	Cost Estimate
Mojave Riverwalk – Phase I	Park Rd. (including Mojave Narrows)	Bear Valley Rd.	I	3.90	\$3,900,000
Mojave Riverwalk – Phase II	4 <sup>th</sup> St.	Mojave River Levee	I	0.13	\$140,000
Mojave Riverwalk – Phase II	Forest Ave.	Park Rd.	II	3.74	\$187,050
Mojave Riverwalk – Phase II	National Trails Hwy.	Hesperia Rd.	III	0.68	\$10,250
			<b>Total</b>	<b>8.45</b>	<b>\$4,237,300</b>

The priority bicycle improvement for the City of Victorville is the Mojave Riverwalk. When finished, the Mojave Riverwalk will provide a continuous Class I bikeway connecting north Victorville to the Victor Valley Community College.

**Pedestrian Facilities**

The City has also identified opportunities to enhance pedestrian facilities. These are described in the 2017 *SBCTA Safe Routes to School Plan (SRTS)* and in the 2017 *SBCTA Points of Interest Pedestrian Plan (PIPP)*. The *SRTS* focuses on improving access to neighborhood schools listed in Table 5.128, while the *PIPP* focuses on improving access to other community assets listed in Table 5.129. Specific improvement recommendations per project are detailed in the *SRTS Plan Phase II – Volume 2* for items in Table 5.128 and the *PIPP* for items in Table 5.129.

Table 5.128  
SRTS Opportunities

Project	Potential Connection to Bikeways, by Status and Class, within ¼ Mile of Project	Number of Improvements Identified	Cost Estimate
Hollyvale E.S.	Planned Class II, III	9	\$517,433
University Preparatory School	Planned Class II, III	4	\$32,737
<b>Total</b>		<b>13</b>	<b>\$550,170</b>

Table 5.129  
PIPP Opportunities

Project	Potential Connection to Bikeways, by Status and Class, within ¼ Mile of Project	Proposed Project Ranking
Mojave Dr Retail & Victor Valley High	Planned Class II, III	1
Victor Plaza Shopping Center	Planned Class II, III	2
Victorville Downtown	Planned Class II, III	3
Center Street Park	Planned Class I, II, III	NR <sup>A</sup>
Hook Park	Planned Class III	NR <sup>A</sup>
Liberty Park/Mountain View Montessori Charter School	Planned Class I, II, III	NR <sup>A</sup>
Mall of Victor Valley	Planned Class I, II, III	NR <sup>A</sup>
Pebble Beach Park	Planned Class I, III	NR <sup>A</sup>
Victor Valley College	Planned Class I, II	NR <sup>A</sup>
Victorville Victor Valley Transit Center/Eva Dell Park	Existing Class I & Planned Class I, II	NR <sup>A</sup>

TABLE NOTES – <sup>A</sup>: NR = “Not Ranked”, listed as potential project locations and not included in above map.

### Municipal Code

The municipal code for the City of Victorville does not currently include the mandatory requirement for the inclusion of non-motorized serving infrastructure as part of the site design process.

### End of Trip Facilities

The City of Victorville has bike racks dispersed throughout the City, typically at retail centers, schools and multi-unit housing complexes.

### Multimodal Connectivity

The City of Victorville has the following multimodal facilities that interface with the non-motorized transportation system.

Table 5.130

Multimodal Connectivity

Facility	Facility Type	Facility Location
Victorville Blvd PNR Lot	Ride Share Lot	Bear Valley Rd & I-15
VVCC PNR	Ride Share Lot	Bear Valley & Fish Hatchery
City-wide Bus Stops	Bus Stops	Throughout City

**Collisions Involving Bicyclists**

Table 5.131

Data for Collisions Involving Bicyclists

Parameter	Collision Rate
Total # of Bicycle Collisions from 2012-2016	45
Total # of Bicycle Fatalities from 2012-2016	0
Total # of Bicycle Injuries from 2012-2016	46
Average # of Bicycle Collisions Per Year	9
Average Bicycle Collision Rate per 1000/year <sup>1</sup>	0.07

Notes:

1. Rate is calculated using SWITRS collision data and population figures by the California Department of Finance

**Safety and Education Programs**

The City of Victorville does not currently participate in any bicycle safety or education programs.



## City of Yucaipa

### Population

54,651

### City Overview

Yucaipa is located in the eastern portion of the San Bernardino Valley area, at the foot of the San Bernardino Mountains, between the Cities of Redlands and Calimesa. The City is bounded on the northwest by the Crafton Hills, on the south by the City of Calimesa and on the north and east by mountainous terrain in unincorporated areas of San Bernardino County.

The topography of the City begins at an approximate elevation of 2,000 feet at the west end, adjacent to the point at which the 10 freeway enters Yucaipa from the west. Elevations increase in the northeast and eastern portions of the City to approximately 4,000+feet, which represents an elevation change of 2,000 feet. Much of the area on the northwest portion of the City above 2,400 feet has been designated by the City as an open space preserve.

### Land Use

The map in Figure 5.37 shows the current and future land use patterns in the City of Yucaipa. The existing land uses within the City can be best summarized as a diversity of land uses throughout with a very low percentage of commercial and industrial land uses. The industrial and commercial areas have been developed in strips as opposed to centers or nodes of development.

### Existing Conditions:

Yucaipa's non-motorized bicycle network has focused on expanding its Class II bike facilities and has introduced Class III bike routes since the last update to the Non-Motorized Transportation Plan. Since the previous update, the City has added 4.59 miles of Class II bike lanes and 4.23 miles of Class III bike routes. In all, the City enjoys one Class I bike path along a section of Oak Glen Road for a stretch of 2.06 miles, 22.02 miles of striped Class II bike lanes, and 4.23 miles of signed Class III bike routes.

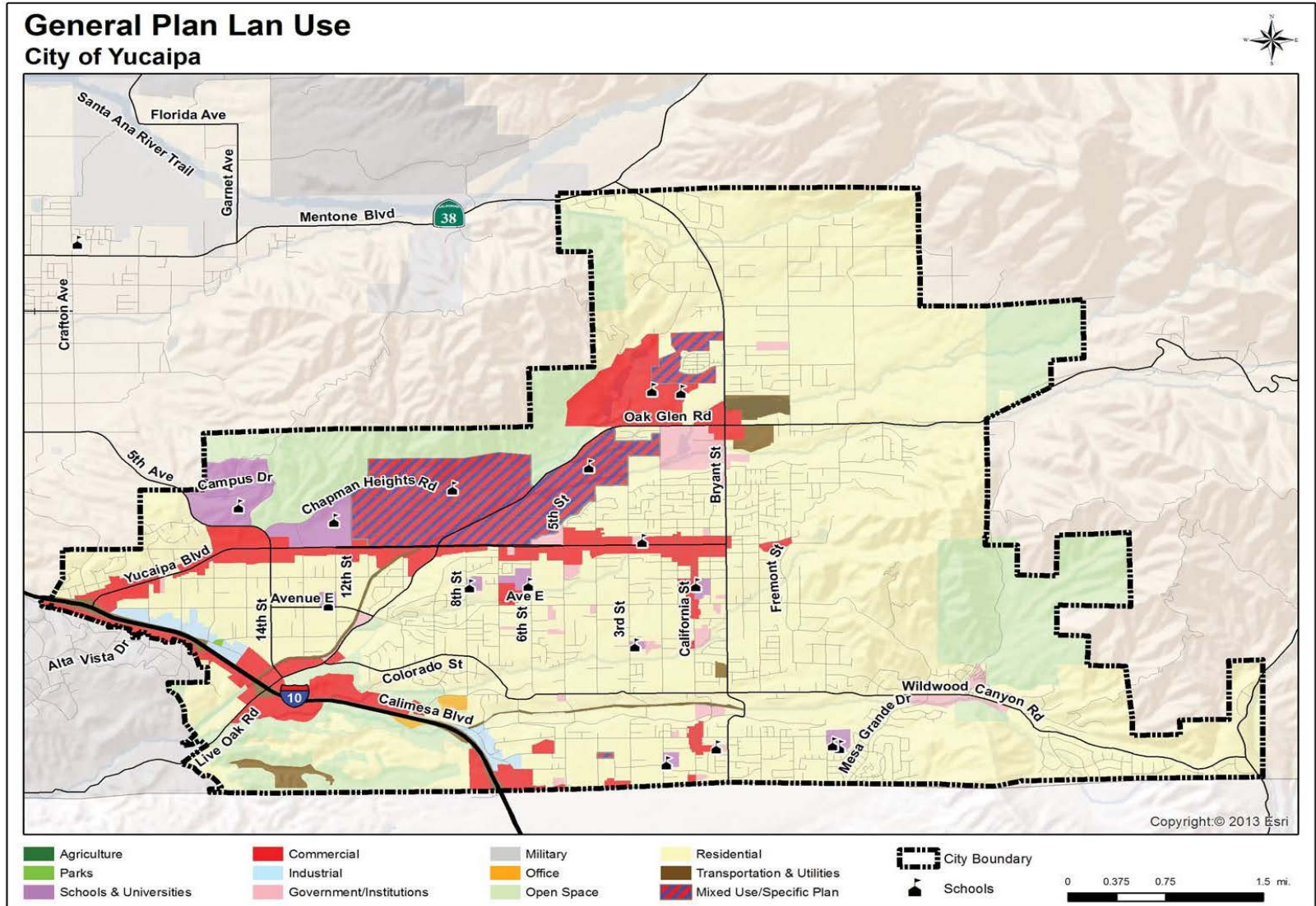
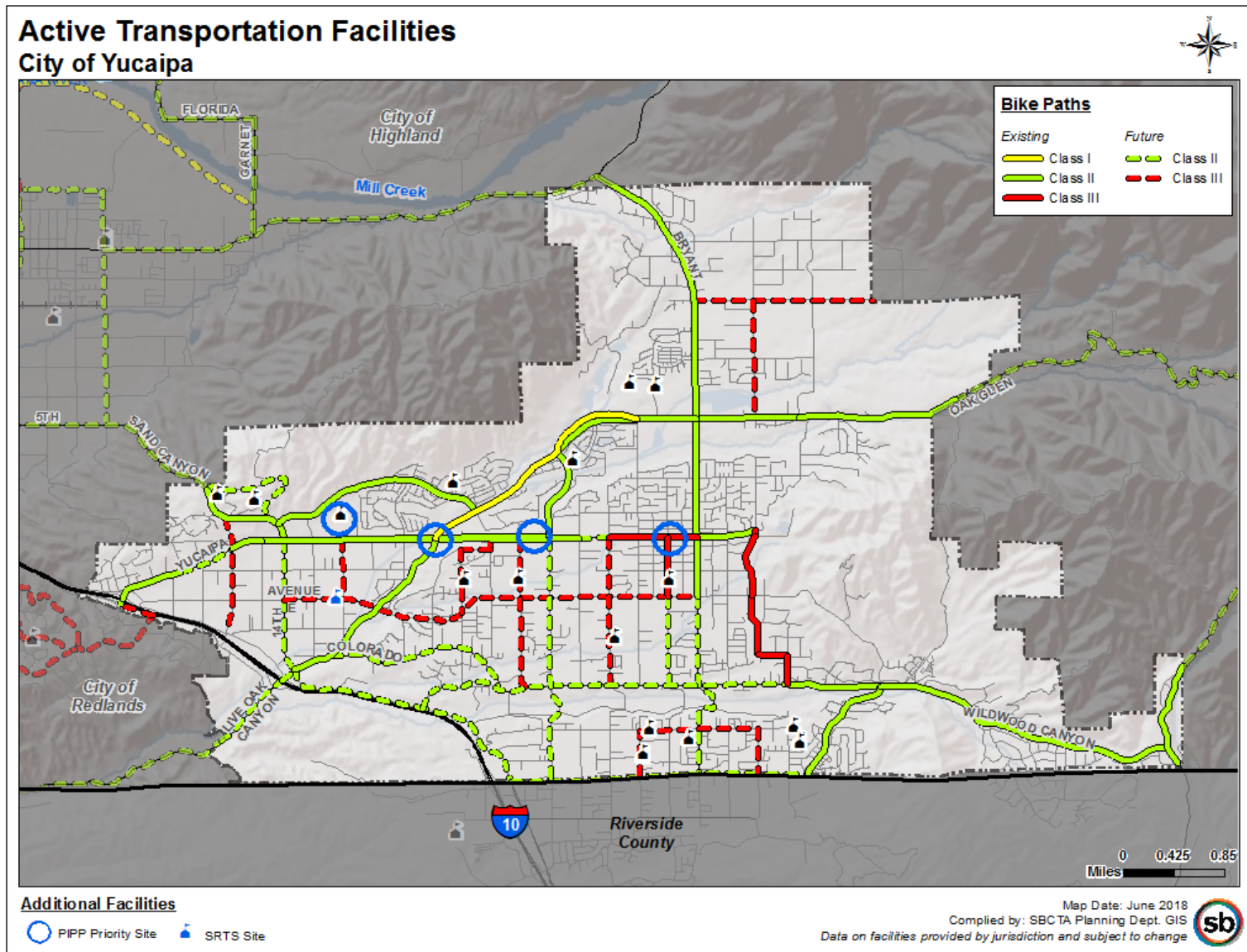

Figure 5.46



C:\Users\christopher\Documents\Projects\BikePlan\_Feb16\start\DataDrivenMaps\ATP\_Landscape.mxd

Figure 5.47

Table 5.132

Yucaipa Existing Conditions

Street/Path	From	To	Class	Length (mi.)	Cost Estimate
5th St.	Oak Glen Rd.	Yucaipa Blvd.	II	0.82	\$41,000
Bella Vista Dr.	Fremont St.	Holmes St.	III	0.28	\$4,200
Bryant St.	SR-38	Avenue E	II	3.91	\$195,500
California St.	Avenue E	Yucaipa Blvd.	III	0.50	\$7,500
Chapman Heights Rd.	Sand Canyon Rd.	Oak Glen Rd.	II	1.86	\$93,000
Fremont St.	Avenue E	Bella Vista Dr.	III	0.52	\$7,800
Fremont St.	Grandview Dr.	Avenue E	III	0.53	\$7,950
Fremont St.	Yucaipa Blvd	Grandview Dr.	III	0.05	\$750
Holmes St.	Bella Vista Dr.	Wildwood Canyon Rd.	III	0.24	\$3,600
Mesa Grande Dr.	Wildwood Canyon Rd.	County Line Rd.	II	1.05	\$52,500
Oak Glen Rd.	2nd St.	Yucaipa Blvd.	I	2.06	\$2,060,000
Oak Glen Rd.	Bryant St.	5th St.	II	1.27	\$63,500
Oak Glen Rd.	Cherry Croft Dr.	Bryant St.	II	0.87	\$43,500
Oak Glen Rd.	Cherry Croft Dr.	s/o Martell Ave	II	1.38	\$69,000
Oak Glen Rd.	Oak Glen Rd.	Scenic Crest Dr.	II	0.51	\$25,500
Oak Glen Rd.	Yucaipa Blvd.	Calimesa Blvd.	II	1.70	\$85,000
Sand Canyon Rd.	N City Limit	Yucaipa Blvd.	II	0.92	\$46,000
Wildwood Canyon Rd.	Holmes St.	Mesa Grande Dr.	II	0.80	\$40,000
Wildwood Canyon Rd.	Mesa Grande Dr.	Oak Glen Rd.	II	2.62	\$131,000
Yucaipa Blvd.	3rd St.	Bryant St.	III	0.73	\$36,500
Yucaipa Blvd.	5th St.	4th St.	II	0.23	\$11,500
Yucaipa Blvd.	I-10	18th St.	II	0.52	\$26,000
Yucaipa Blvd.	15th St.	5th St.	II	4.19	\$209,500
Yucaipa Blvd.	15th St.	16th St.	II	0.26	\$13,000
Yucaipa Blvd.	Bryant St.	Fremont St.	II	0.49	\$24,500
			<b>Total</b>	<b>28.31</b>	<b>\$3,298,300</b>

*Growth/Past investment in system*

Since the San Bernardino County Non-Motorized Transportation Plan was first prepared in 2001, the City of Yucaipa has constructed 2.06 miles of Class I, 18.49 miles of Class II, and 4.23 miles of Class III bikeways at a rate of 1.55 miles per year.

*Past Investment in Non-Motorized Infrastructure*

The improvements included in Table 5.132 above constitute a significant investment into the non-motorized transportation infrastructure of Yucaipa. Based on planning level estimates, the value of the improvements implemented throughout the City is \$3,298,300.



**Proposed Improvements**

Future improvements to the non-motorized network for the City of Yucaipa will continue along the major transportation corridors throughout the City. All future improvements focus on further development of additional Class II and Class III facilities. A table of future improvements is included in Table 5.133 below.

Table 5.133

Yucaipa Future Improvements

Street/Path	From	To	Class	Length (mi.)	Cost Estimate
12th St.	Yucaipa Blvd.	Avenue E	III	0.50	\$7,500
14th St.	Yucaipa Blvd.	Oak Glen Rd.	II	1.11	\$55,500
2nd St.	Avenue H	County Line Rd.	III	0.39	\$5,850
3rd St.	Yucaipa Blvd.	Wildwood Canyon Rd.	III	1.25	\$18,750
5th St.	Yucaipa Blvd.	County Line Rd.	II	2.05	\$102,500
6th St.	Yucaipa Blvd.	Wildwood Canyon Rd.	III	1.26	\$18,900
7th St.	Yucaipa Blvd.	Washington Dr.	III	0.09	\$1,350
8th St.	Washington Dr.	Ave. E	III	0.53	\$7,950
16th St.	Sand Canyon Rd.	I-10	III	1.00	\$15,000
Avenue E	12 <sup>th</sup> St.	Bryant St.	III	3.10	\$46,500
Avenue E	14 <sup>th</sup> St.	12 <sup>th</sup> St.	III	0.50	\$7,500
Avenue H	2nd St.	Fremont St.	III	1.00	\$15,000
Bryant St.	Avenue E	County Line Rd.	II	1.68	\$84,000
California St.	Wildwood Canyon Rd.	Avenue E	II	0.75	\$37,500
Calimesa Blvd.	Oak Glen Rd.	S City Limit	II	2.26	\$113,000
Campus Dr.	Sand Canyon Rd.	Sand Canyon Rd.	II	1.10	\$55,000
Carter St.	Bryant St.	e/o Jefferson St.	III	1.50	\$22,500
Colorado St.	Oak Glen Rd.	Wildwood Canyon Rd.	II	1.64	\$82,000
County Line Rd.	Mesa Grande Dr.	Calimesa Blvd	II	2.52	\$126,000
Fremont St.	Avenue H	County Line Rd.	III	0.38	\$5,700
Fremont St.	Carter St.	Oak Glen Rd.	III	1.00	\$15,000
Live Oak Canyon Rd.	W. City Limit	I-10	II	0.62	\$31,000
Oak Glen Rd.	I-10	Calimesa Blvd.	II	0.13	\$6,500
Outer Highway 10	Yucaipa Blvd.	Alta Vista Dr.	III	0.29	\$4,350
Washington Dr.	8th St.	7th St.	III	0.25	\$3,750
Wildwood Canyon Rd.	Calimesa Blvd.	Holmes St.	II	3.23	\$161,500
Yucaipa Blvd.	4th St.	3rd St.	II	0.23	\$11,500
Yucaipa Blvd.	16th St.	18th St.	II	0.50	\$25,000
Yucaipa Blvd.	I-10	Outer Highway 10	II	0.04	\$2,000
			<b>Total</b>	<b>30.90</b>	<b>\$1,088,600</b>

The City of Yucaipa has identified three projects as priorities, which are included in Table 5.134 below. The projects focus on completing the Class II improvements along Yucaipa Boulevard and County Line Road. Upon completion of the priority improvements, the City will have constructed an additional 3.25 miles of Class II facilities.

The City of Yucaipa has identified the following improvements as the top priority improvements to the non-motorized network in the City:

Table 5.134

Priority Improvements

Street/Path	From	To	Class	Length (mi.)	Cost Estimate
County Line Rd	Mesa Grande Dr.	Calimesa Blvd.	II	2.52	\$126,000
Yucaipa Blvd.	4th St.	3rd St.	II	0.23	\$11,500
Yucaipa Blvd.	16th St.	18th St.	II	0.50	\$25,000
			<b>Total</b>	<b>3.25</b>	<b>\$162,500</b>

**Pedestrian Facilities**

The City has also identified opportunities to enhance pedestrian facilities. These are described in the 2017 *SBCTA Safe Routes to School Plan (SRTS)* and in the 2017 *SBCTA Points of Interest Pedestrian Plan (PIPP)*. The *SRTS* focuses on improving access to neighborhood schools listed in Table 5.135, while the *PIPP* focuses on improving access to other community assets listed in Table 5.136. Specific improvement recommendations per project are detailed in the *SRTS Plan Phase II – Volume 2* for items in Table 5.135 and the *PIPP* for items in Table 5.136.

Table 5.135

SRTS Opportunities

Project	Potential Connection to Bikeways, by Status and Class, within ¼ Mile of Project	Number of Improvements Identified	Cost Estimate
Dunlap E.S.	Planned Class III	10	\$541,310
		<b>Total</b>	<b>10</b>
			<b>\$541,310</b>



Table 5.136  
PIPP Opportunities

Project	Potential Connection to Bikeways, by Status and Class, within ¼ Mile of Project	Proposed Project Ranking
John Tooker Civic Park & Yucaipa Square Shopping Center	Existing Class II & Planned Class III	1
Yucaipa High near Yucaipa Blvd Retail	Existing Class II & Planned Class III	2
Ave A Park & Retail Corridor along California/Yucaipa	Existing Class II, III	3
Yucaipa Valley Center Yucaipa Blvd/Oak Glen Rd	Existing Class I, II & Planned Class III	4
7th Street Park/Oak View High School	Planned Class III	NR <sup>A</sup>
Flag Hill Park	Existing Class II, III	NR <sup>A</sup>
I Street Park	Planned Class II	NR <sup>A</sup>
Wildwood Park	Existing Class II	NR <sup>A</sup>
Yucaipa Community & Regional Parks	Existing Class I, II	NR <sup>A</sup>

TABLE NOTES – <sup>A</sup>: NR = “Not Ranked”, listed as potential project locations and not included in above map.

**Municipal Code**

Yucaipa Municipal Code 10.08.010, Chapter 10.08 Transportation Control Sub-regional Implementation Program includes several design standards for residential and non-residential development pertaining to the provision of bicycle parking. The design standards are as follows:

- *Bicycle Parking Facilities* – New non-residential and multi-family (of 10 or more units) development or remodels of existing complexes (when discretionary review is required) are required to include parking racks or secured lockers at a rate of 1 per 30 parking spaces with a minimum of a three-bike rack.
- *Pedestrian and Bicycle Connections to Public Streets* – New non-residential and multi-family (of 10 or more units) are required to provide on-site pedestrian walkways and bicycle facilities to connect each building in the development to public streets.
- *Shower Facilities* – New non-residential development meeting CMP thresholds (250 or more peak hour trips) are required to provide shower facilities for persons bicycling or walking to work at a minimum of one shower facility accessible to both men and women.

**End of Trip Facilities**

The City of Yucaipa has bike racks dispersed throughout the City, typically at retail centers and multi-unit housing complexes.

**Multimodal Connectivity**

The City’s General Plan, updated in April of 2016, incorporates the Complete Streets Act of 2008. As a result, the planning and implementation of transportation infrastructure projects in the City focuses on enhancing the multimodal transportation network that serves motorized and non-motorized modes of transportation. As such, Yucaipa’s street system is designed to encourage and promote bicycling and walking as viable and alternative means of transportation.

The City of Yucaipa has the following multimodal facilities that interface with the non-motorized transportation system.

Table 5.137

Multimodal Connectivity

Facility	Facility Type	Facility Location
Yucaipa Blvd PNR Lot	Ride Share Lot	31341 Hampton Rd
Yucaipa Transit Center	Multi-Modal Facility	34276 Yucaipa Blvd
City-wide Bus Stops	Bus Stops	Throughout City

**Collisions Involving Bicyclists**

Table 5.138

Data for Collisions Involving Bicyclists

Parameter	Collision Rate
Total # of Bicycle Collisions from 2012-2016	24
Total # of Bicycle Fatalities from 2012-2016	1
Total # of Bicycle injuries from 2012-2016	23
Average # of Bicycle Collisions Per Year	4.8
Average Bicycle Collision Rate per 1000/year <sup>1</sup>	0.09

Notes:

1. Rate is calculated using SWITRS collision data and population figures by the California Department of Finance

## **Safety and Education Programs**

The City sponsors an annual Bike Safety Rodeo. The activities are geared for kids from ages 3 - 14. The event features complimentary bike and helmet inspections, as well as a bicycle safety course food and giveaways.

In addition, the City also partners with the Yucaipa-Calimesa Joint Unified School District and the San Bernardino County Department of Public Health's Safe Routes to School Program in conducting public workshops at various elementary schools throughout the City to provide bicycle and pedestrian safety/education and encourage walking and bicycling to school.

## Town of Yucca Valley

### **Population**

20,764

### **City Overview**

The Town of Yucca Valley comprises an important administrative, commercial and business center for the Morongo Basin and Lower Mojave Desert region. Located in the south-central portion of San Bernardino County and a transitional area between the high and low deserts of southeastern California, the Town sits at a pivotal location in terms of the region's geology. Both resulting climate and geotechnical activity have shaped Yucca Valley.

### **Land Use**

The Town encompasses over 38 square miles. Historically, development has been focused along, and been most intense, adjacent to State Highway 62, with progressively less dense and more scattered residential development north and south of Highway 62. Industrial land uses are found in a few scattered locations, and the Highway 62 corridor serves the Town and the region as an integrated mix of commercial businesses.

The goals identified in Yucca Valley's General plan include maintaining a balance of mixed, functionally integrated land uses which meet general, social and economic needs and promoting a well-rounded community of desirable neighborhoods with a strong employment base and a variety of community facilities.

### **Existing Conditions:**

The Town of Yucca Valley's bicycle transportation system is comprised solely of Class III bike routes. The 23.41 miles of bike routes provide access to the both the north and south sections of Town, crossing SR-62 and SR-247.

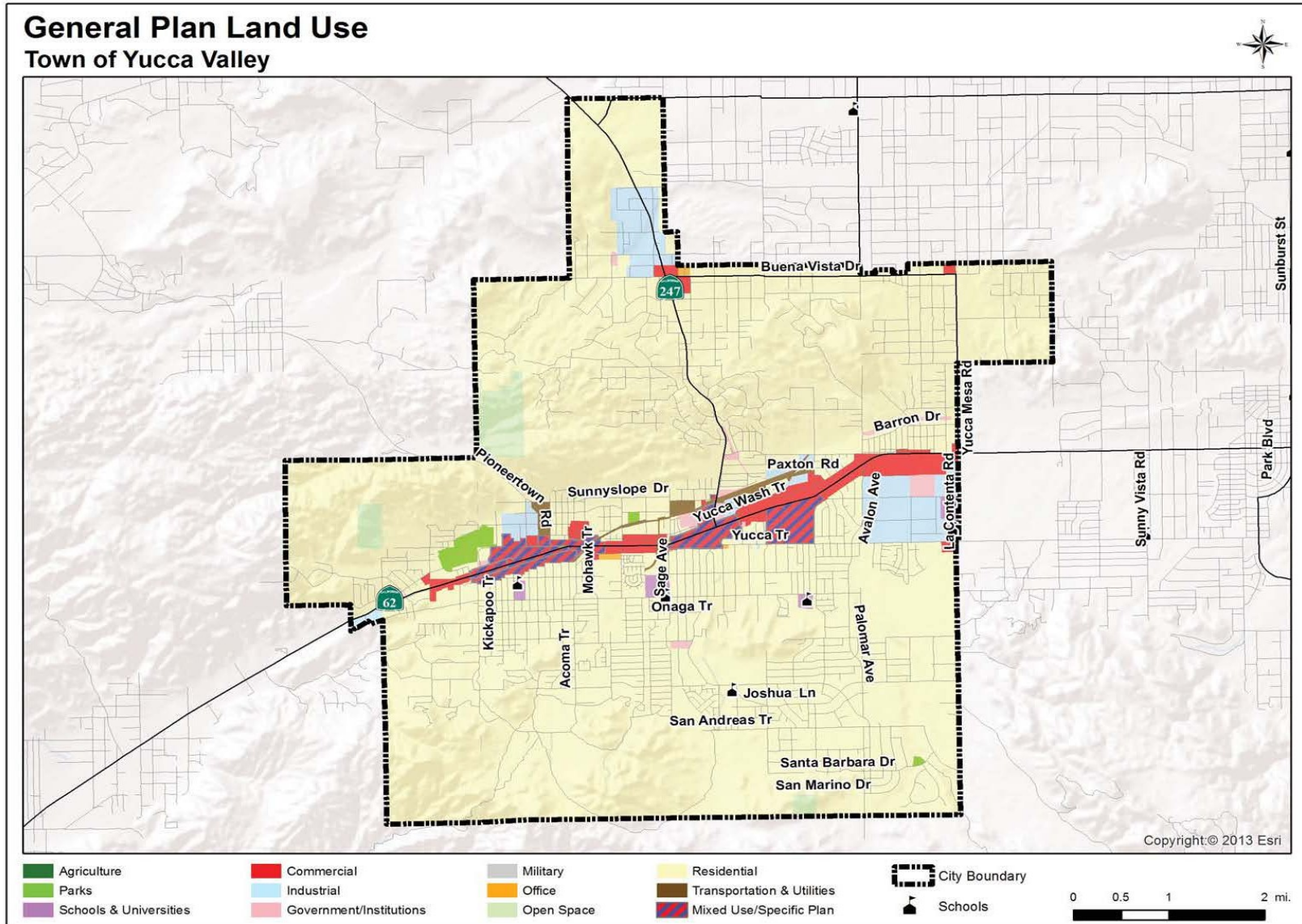

Figure 5.48



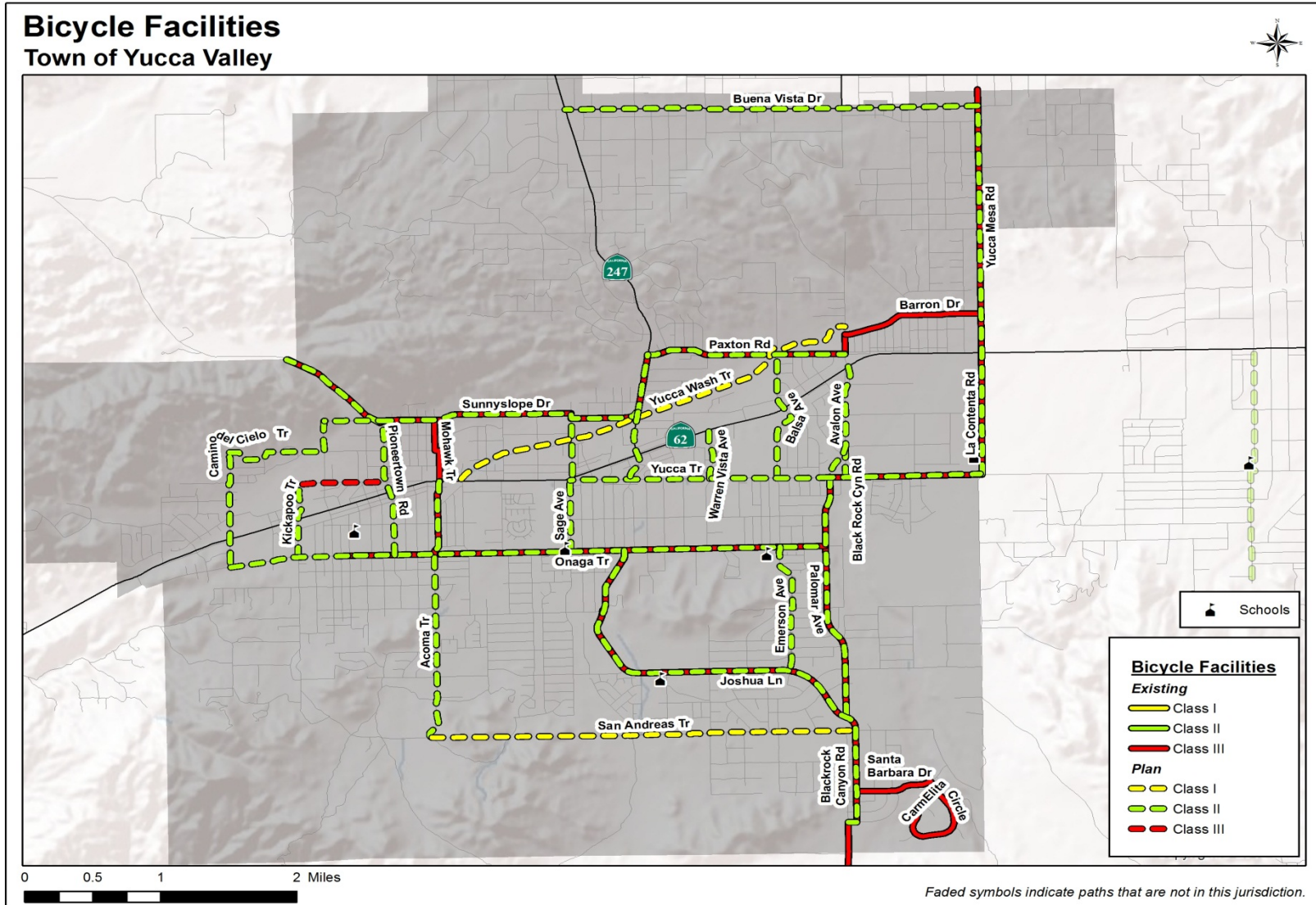

Figure 5.49



Table 5.139

Yucca Valley Existing Conditions

Street/Path	From	To	Class	Length (mi.)	Cost Estimate
Acoma Trail	Onaga Trail	SR-62	III	0.60	\$9,000
Avalon Ave.	Paxton Rd.	Barron Dr.	III	0.16	\$2,400
Barron Dr.	Avalon Ave.	Yucca Mesa Rd.	III	1.04	\$15,600
Blackrock Canyon Rd.	San Marino Dr.	End	III	1.08	\$16,200
Carmelita Circle	Santa Barbara Dr.	Santa Barbara Dr.	III	1.15	\$17,250
Joshua Ln.	Onaga Trail	San Marino Dr.	III	3.76	\$56,400
La Contenta Rd.	SR-62	Yucca Trail	III	0.99	\$14,850
Mohawk Trail	SR-62	Sunnyslope Dr.	III	0.53	\$7,950
Onaga Trail	Hopi Trail	Palomar Ave.	III	3.50	\$52,500
Palomar Ave.	Yucca Trail.	Joshua Ln.	III	1.99	\$29,850
Paxton Rd.	SR-247	Avalon Ave.	III	1.47	\$22,050
Pioneertown Rd.	Sunnyslope Dr.	N Town Limits	III	0.82	\$12,300
San Marino Dr.	Joshua Ln.	Black Rock Canyon Rd.	III	0.06	\$900
Santa Barbara Dr.	Joshua Ln.	Carmelita Circle.	III	0.56	\$8,400
SR-247	Sunnyslope Dr.	Paxton Rd.	III	0.47	\$7,050
Sunnyslope Dr.	Pioneertown Rd.	SR-247	III	1.97	\$29,550
Yucca Mesa Rd.	SR-62	N Town Limits	III	2.14	\$32,100
Yucca Trail	La Contenta Rd.	Palomar Ave.	III	1.12	\$16,800
			<b>Total</b>	<b>23.41</b>	<b>\$351,150</b>

*Growth/Past investment in system*

Since the San Bernardino County Non-Motorized Transportation Plan was first prepared in 2001, the Town of Yucca Valley has designated 23.41 miles of Class III facilities within the Town at a rate of 2.3 miles per year.

*Past Investment in Non-Motorized Infrastructure*

The improvements included in Table 5.139 above demonstrate a commitment to non-motorized transportation within the Town of Yucca Valley. Based on planning level estimates, the value of the improvements implemented throughout the Town is \$351,150.

**Proposed Improvements**

The future improvements identified by the Town of Yucca Valley will upgrade most of the existing Class III facilities to Class II standards. When complete, along with the construction of new Class I and Class II bikeways, the Town will have a total of 46.25 miles of bikeways, improving the safety to cyclists and reinforcing their place in the Town's arterial system.

Table 5.140

Yucca Valley Future Improvements

Street/Path	From	To	Classes	Length (mi.)	Cost Estimate
Acoma Trail	San Andreas Rd.	SR-62	II	2.10	\$105,000
Avalon Ave.	Yucca Trail	SR-62	II	0.89	\$44,500
Balsa Ave.	Yucca Trail	Paxton Rd.	II	1.08	\$54,000
Black Rock Cyn. Rd.	Miramar Dr.	Yucca Trail	II	0.25	\$12,500
Buena Vista Dr.	Yucca Mesa Rd.	SR-247	II	2.77	\$138,500
Camino del Cielo Trail	Onaga Trail	Sunnyslope Dr.	II	2.08	\$44,500
Emerson Ave.	Onaga Trail.	Joshua Ln.	II	1.06	\$53,350
Joshua Ln.	Onaga Trail	San Marino Dr.	II	3.80	\$190,000
Kickapoo Trail	Onaga Trail	Yucca Trail	II	0.59	\$29,500
Onaga Trail	Camino del Cielo Trail	Palomar Ave.	II	4.38	\$94,500
Palomar Ave.	Yucca Trail	Joshua Ln.	II	2.01	\$100,500
Paxton Rd.	SR-247	Avalon Ave.	II	4.73	\$73,000
Pioneertown Rd.	Onaga Trail	Town Boundary	II	1.89	\$94,500
Sage Ave.	Onaga Trail	Sunnyslope Dr.	II	1.04	\$52,000
San Andreas Trail	Joshua Ln.	Acoma Trail	I	3.07	\$3,070,000
San Marino Dr.	Joshua Ln.	Black Rock Cyn. Rd.	II	0.08	\$4,000
SR-247	Sunnyslope Dr.	Paxton Rd.	II	0.49	\$24,500
SR-247	Sunnyslope Dr	Yucca Tr.	II	0.57	\$28,860
Sunnyslope Dr.	Camino del Cielo Trail	SR-247	II	3.11	\$155,500
Warren Vista Ave.	Yucca Trail	SR-62	II	0.42	\$21,000
Yucca Mesa Rd.	Yucca Trail	Buena Vista Dr.	II	2.99	\$149,500
Yucca Trail	Kickapoo Trail	Pioneertown Rd.	III	0.64	\$9,600
Yucca Trail	Sage Ave.	La Contenta Rd.	II	3.01	\$150,500
Yucca Wash Trail	SR-62	Avalon Ave.	I	3.20	\$3,200,000
			<b>Total</b>	<b>46.25</b>	<b>\$7,899,810</b>

**Municipal Code**

The Town of Yucca Valley has not adopted Municipal Code specific to non-motorized transportation or the placement of non-motorized transportation facilities.

**End of Trip Facilities**

The Town of Yucca Valley has bike racks dispersed throughout the Town, typically at retail centers, schools and multi-unit housing complexes. The Town of Yucca Valley also possesses bicycle lockers at the park-and-ride facility located at the intersection of SR-62 and Kickapoo Trail.

## Multimodal Connectivity

Table 5.141

### Location of Multi-Modal Connections

Facility	Facility Type	Facility Location
Yucca Valley Transfer Center	Bus Transfer Center	Yucca Trail/Airway
Yucca Valley PNR	Ride Share Lot	7485 Kickapoo Trail
City-wide Bus Stops	Bus Stops	Throughout City

## Collisions Involving Bicyclists

Table 5.142

### Data for Collisions Involving Bicyclists

Parameter	Collision Rate
Total # of Bicycle Collisions from 2005-2009	12
Total # of Bicycle Fatalities from 2005-2009	1
Average # of Bicycle Collisions Per Year	2.4
Average Bicycle Collision Rate per 1000/year <sup>1</sup>	0.12

Notes:

1. Rate is calculated using SWITRS collision data and population figures by the California Department of Finance

## Safety and Education Programs

The Town of Yucca Valley does not currently participate in any bicycle safety or education programs.

## County of San Bernardino

### Population

296,550

### County Overview

The area that would become the County of San Bernardino was originally part of the huge San Diego County in 1850. A year later, it became part of the expanding Los Angeles County. In April 1853, a bill was introduced to split off the eastern portion of Los Angeles County to form a separate county; and on April 26, 1853, San Bernardino County was created from parts of Los Angeles, San Diego, and Mariposa counties. In 1854, the City of San Bernardino was incorporated as the County seat. In 1893, Riverside County was created out of parts of San Bernardino and San Diego counties. The County of San Bernardino remains the largest county in the contiguous United States.

### Land Use

The County identifies three diverse planning regions—including the Valley, Mountains and Desert regions—which vary not only by terrain, but also in the issues and opportunities they face. Each of the three areas is mentioned in greater detail below.

- **Valley:** The Valley Planning Region is defined as all the area within the County that is south and west of the U.S. Forest Service boundaries. The San Bernardino range, trending southeast, forms the eastern limit of the Valley, along with the Yucaipa and Crafton Hills. The southern limits of the valley are marked by alluvial highlands extending south from the San Bernardino and the Jurupa Mountains. The Valley Planning Region of the County is approximately 60 miles east of the Pacific Ocean and borders Los Angeles, Orange, and Riverside counties. It is approximately 50 miles long from west to east and encompasses 500 square miles. It covers only 2.5 percent of the total County land, but holds approximately 75 percent of the County's population. Most of the valley land is incorporated.
- **Mountains:** North of the Valley Planning Region is the Mountain Planning Region, consisting of the San Bernardino and San Gabriel ranges. Of the 872 square miles within this planning region, approximately 715 square miles are public lands managed by state and federal agencies—principally, the U.S. Forest Service. The region contains forests, meadows, and lakes. The San Gabriel Mountains, which extend from Los Angeles County, form the western end of the Mountain Planning Region. The San Gabriel Mountains comprise about one-third of the Mountain Planning Region, with the San Bernardino Mountains making up the remainder.

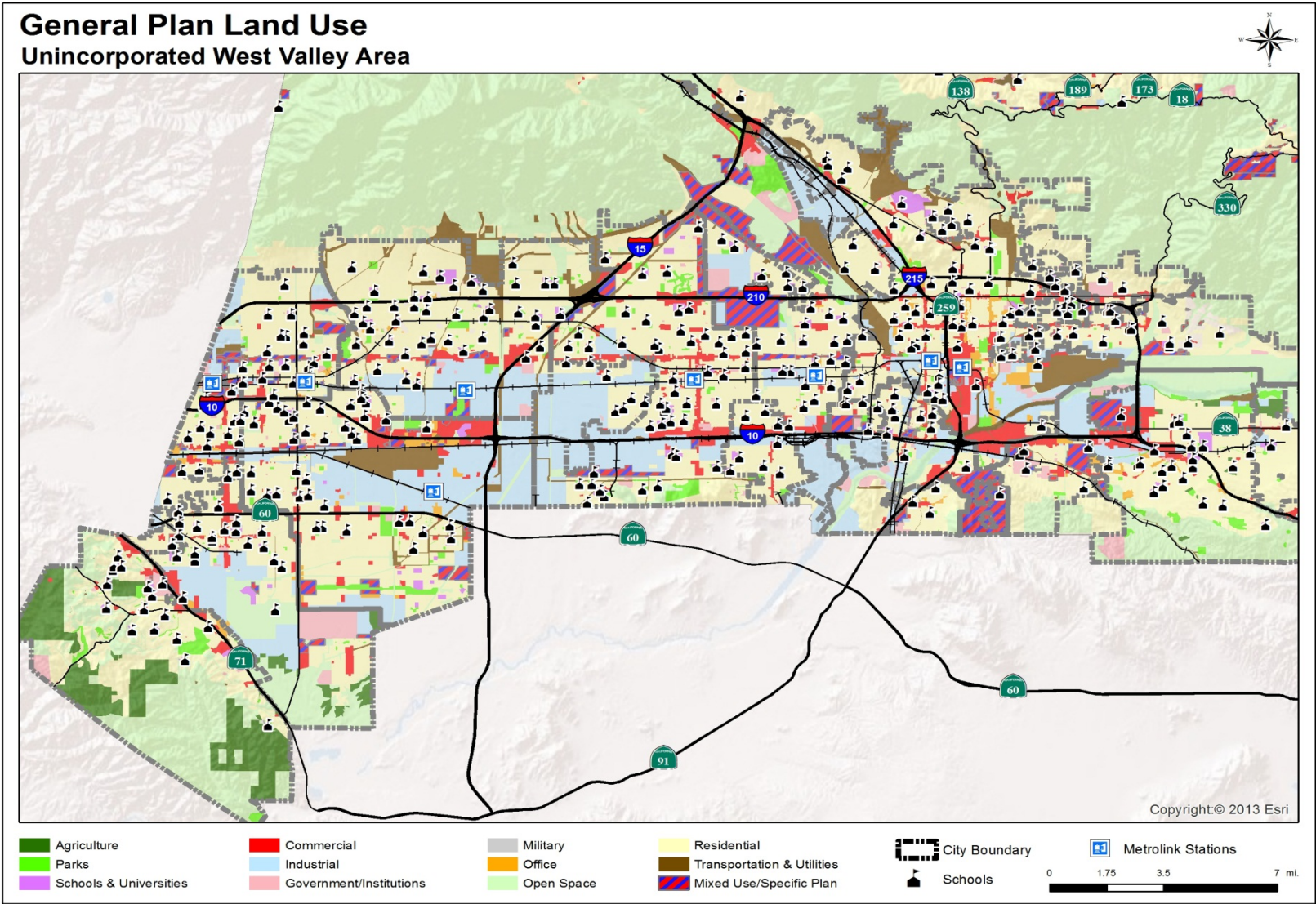

Figure 5.50



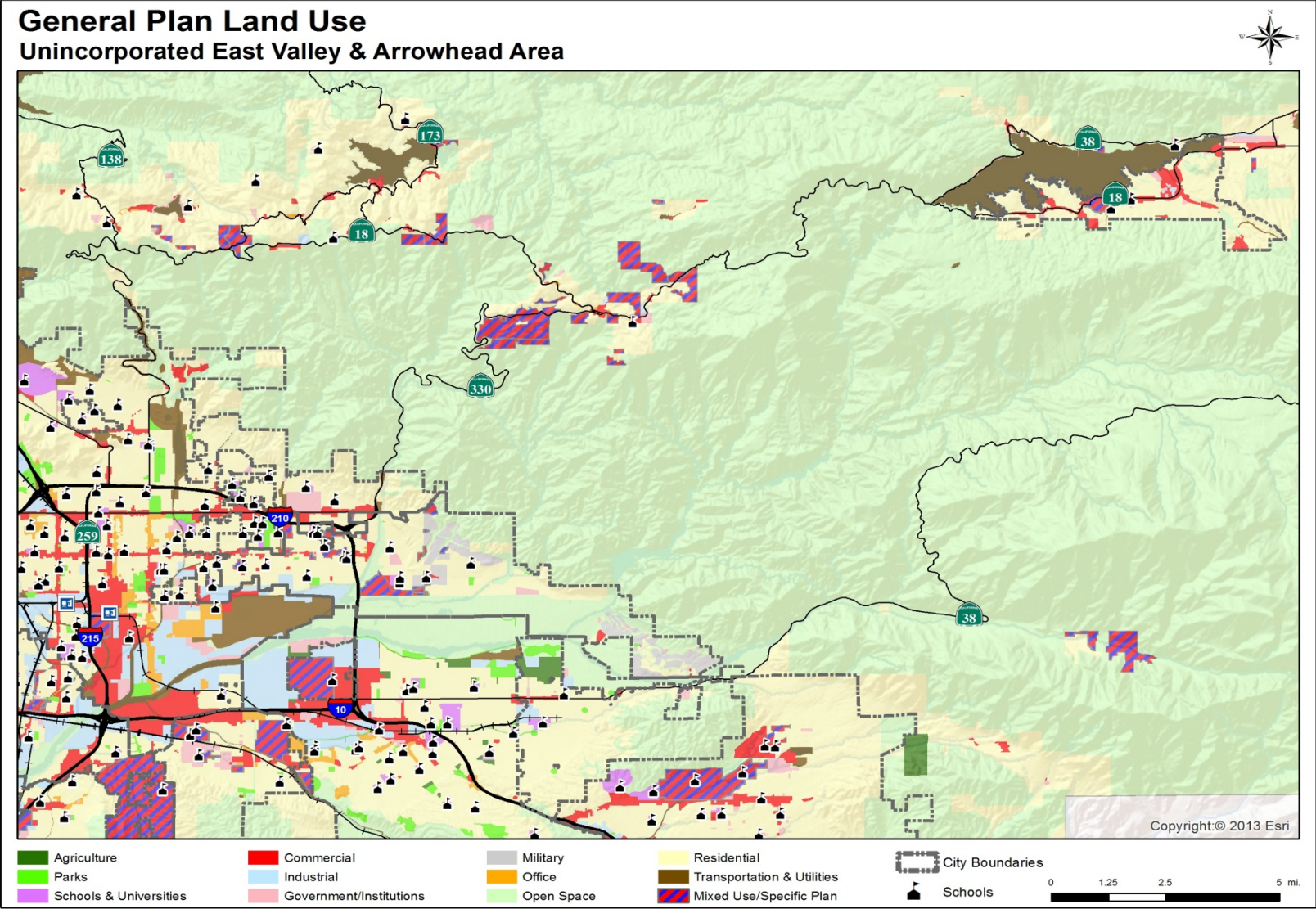

Figure 5.51  
5-207



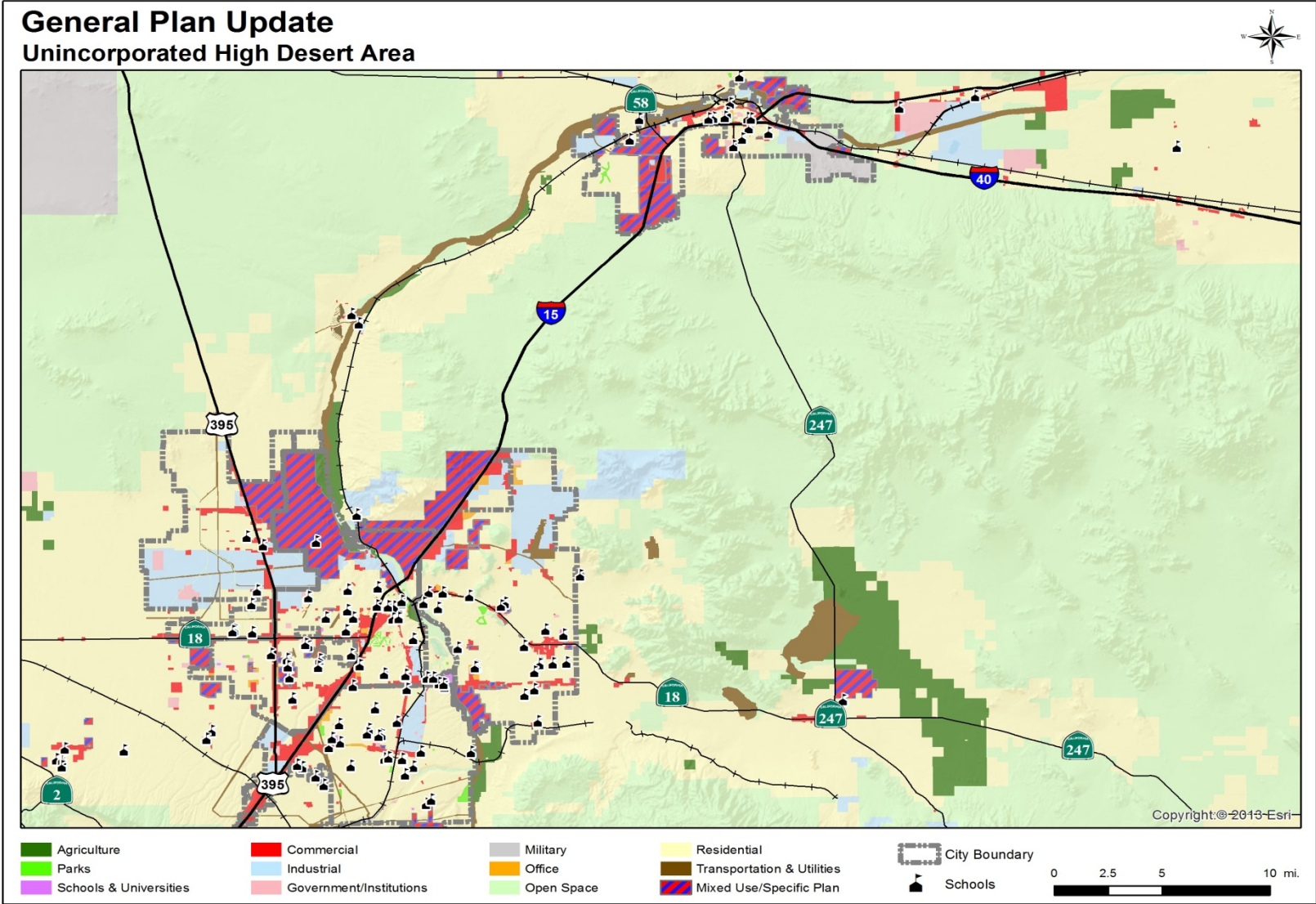

Figure 5.52

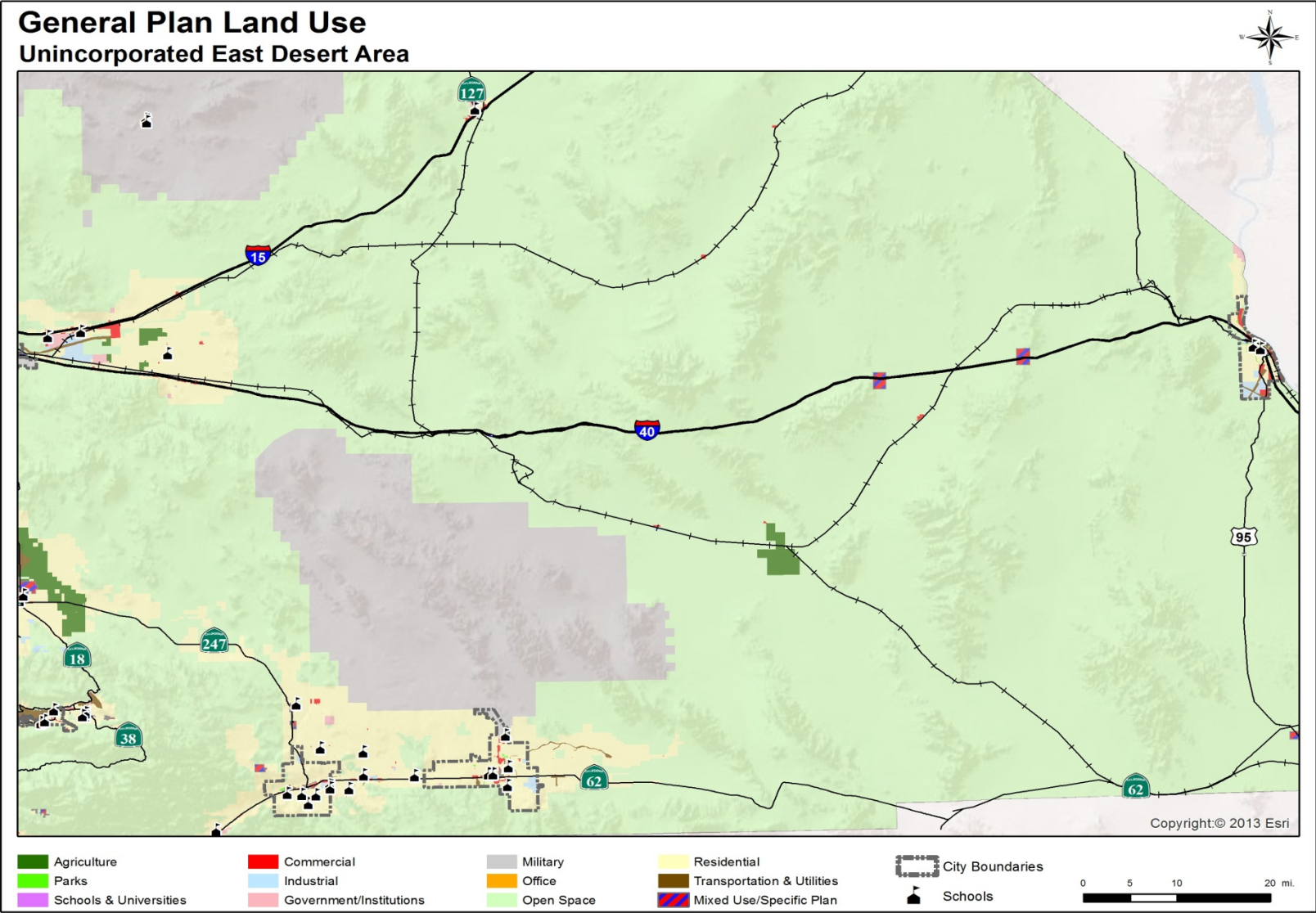

Figure 5.53  
5-209



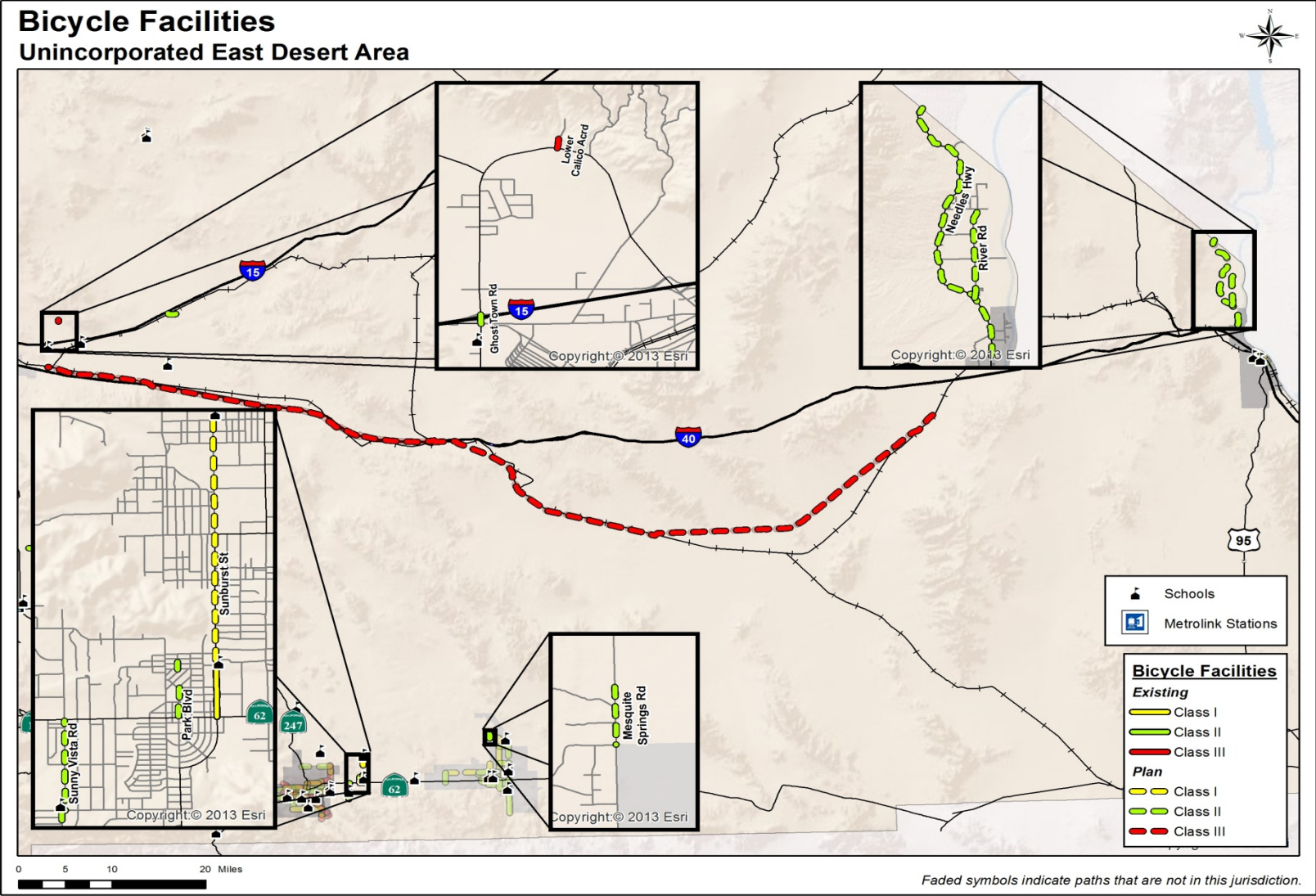

Figure 5.54

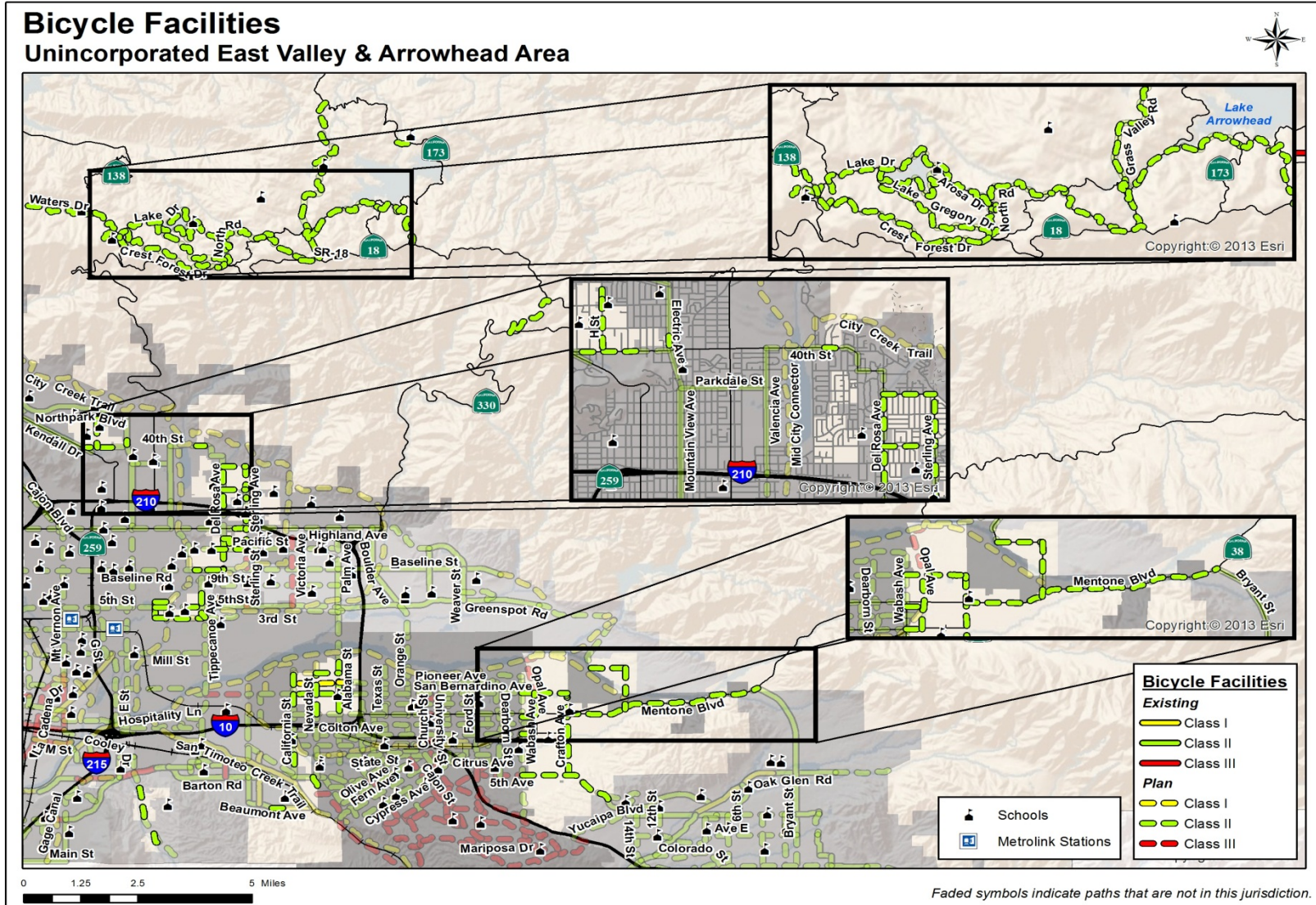
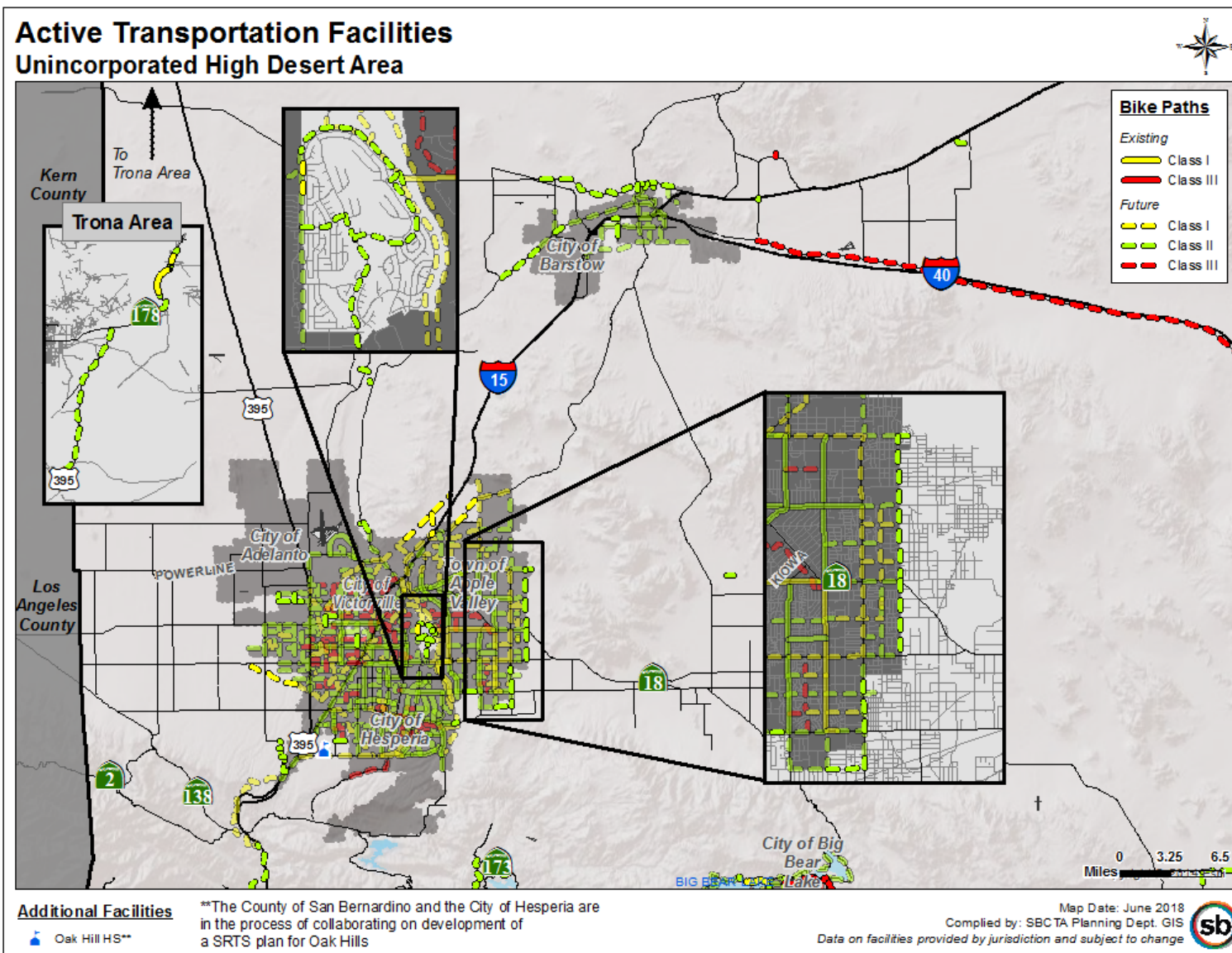

Figure 5.55





C:\Users\christopher\Documents\Projects\BikePlan\_Feb16\start\DataDrivenMaps\ATP\_Landscape\_County\_HighDesert.mxd

Figure 5.56  
5-212

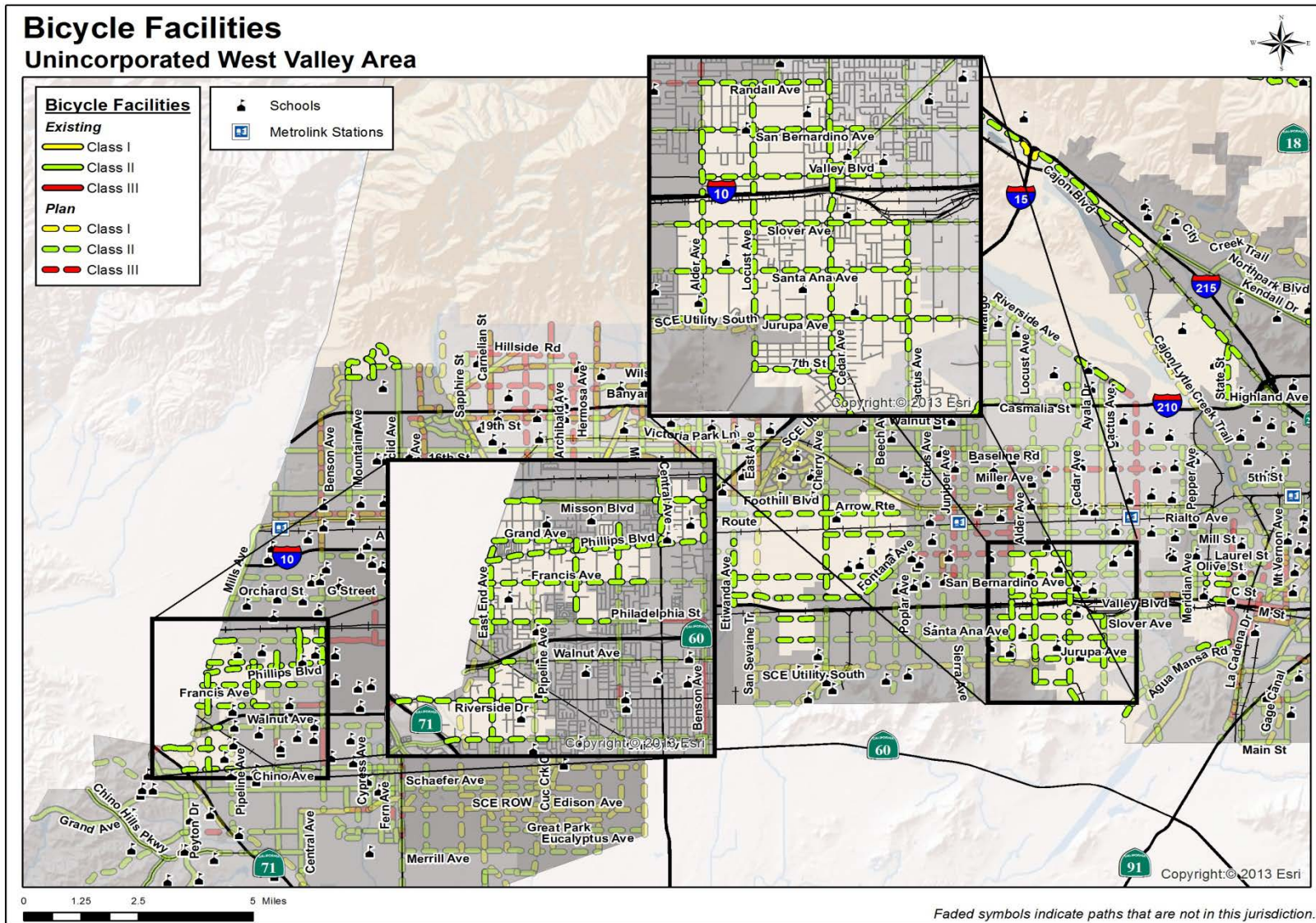

Figure 5.57



- Desert: For purposes of Measure I, the Desert Planning Region, includes the Victor Valley, Morongo Basin, Mountains and Colorado River subareas. The Desert Planning Region is also the largest of the three planning regions, includes a significant portion of the Mojave Desert and contains about 93 percent (18,735 square miles) of the land within San Bernardino County. The Desert Planning Region is defined as including all of the unincorporated area of San Bernardino County lying north and east of the Mountain Planning Region. The Desert Planning Region is an assemblage of mountain ranges interspersed with long, broad valleys that often contain dry lakes.

**Existing Conditions:**

The County of San Bernardino has a total of 9.33 miles of Class I facility in the North Desert, Morongo Basin and Mountains areas. The existing conditions within the County of San Bernardino included in Table 5.143 below.

Table 5.143

County of San Bernardino Existing Conditions

Street/Path	From	To	Class	Length (mi.)	Cost Estimate
Aeroplane Blvd.	Division Dr.	Mt. Doble Dr.	III	1.28	\$19,200
Alpine Pedal Path	SR-38	Woodland Tr.	I	1.52	\$1,520,000
Barranca Blvd.	Country Club Blvd.	Shay Rd.	III	0.07	\$1,050
Big Bear Blvd.	Greenspot Blvd.	Bramble Bush Tr.	III	1.11	\$16,650
Bluebill Dr.	Mtn. View Blvd.	Elysian Blvd.	III	0.23	\$3,450
Country Club Blvd.	Shore Dr.	Barranca Blvd.	III	0.07	\$1,050
Elysian Blvd.	Bluebill Dr.	Shore Dr.	III	0.13	\$1,950
Greenspot Blvd.	Shay Blvd.	Country Club Blvd.	III	0.05	\$750
Mt. Doble Dr.	Aeroplane Blvd.	Mtn. View Blvd.	III	0.19	\$2,850
Mtn. View Blvd.	Mt. Doble Dr.	Bluebill Dr.	III	0.57	\$8,550
Shay Rd.	Barranca Blvd.	Greenspot Blvd.	III	0.24	\$3,600
Shore Dr.	Elysian Blvd.	Country Club Blvd.	III	0.23	\$3,450
Sunburst St.	SR-62	Oleander Dr.	I	3.26	\$3,260,000
Trona Rd.	Center St.	Adams St.	I	3.76	\$3,760,000
Trona Rd.	Marshall St.	Athol St.	I	0.79	\$790,000
			<b>Total</b>	<b>13.50</b>	<b>\$9,392,550</b>

*Growth/Past investment in system*

Since the San Bernardino County Non-Motorized Transportation Plan was first prepared in 2001, the County of San Bernardino has constructed 13.5 miles of Class I facilities at a rate of 1.35 miles per year.

*Past Investment in Non-Motorized Infrastructure*

The improvements included in Table 5.143 above provide important pedestrian and bicycle connections within rural Desert communities. Based on planning level estimates, the value of the improvements implemented throughout the City is \$9,392,550.

**Proposed Improvements**

The list of future improvements within the County of San Bernardino is extensive. A table of future improvements is included in Table 5.144 below.

Table 5.144

County of San Bernardino Proposed Improvements

Street/Path	From	To	Class	Length (mi.)	Cost Estimate
1st St.	Old State 58	0.46mi. NE Irwin Rd.	II	0.33	\$16,500
23rd St.	Mountain Ave.	San Antonio Ave.	II	0.54	\$27,000
24th St.	San Antonio Ave.	Euclid Ave.	II	0.56	\$28,000
3rd St.	Waterman Ave.	Tippecanoe Ave.	II	1.10	\$55,000
40th St.	0.03mi. E 3rd Ave.	0.06mi. W Johnson St.	II	0.55	\$27,500
40th St.	0.08mi. W Golden Ave.	E 0.19mi	II	0.18	\$9,000
5th St.	Wabash Ave.	Crafton Ave.	II	2.26	\$113,000
5th St.	Waterman Ave.	Tippecanoe Ave.	II	0.81	\$40,500
6th St.	Waterman Ave.	Mid City Connector	II	0.33	\$16,500
7th St.	Locust Ave.	Cedar Ave.	II	0.76	\$38,000
Agua Mansa Rd.	0.16mi S Holly	0.07mi. N El Rivino Rd.	II	0.37	\$18,500
Agua Mansa Rd.	0.80mi W Rancho Ave.	E 0.73mi.	II	0.67	\$34,000
Alabama St.	Lugonia Ave.	0.28mi N Palmetto Ave.	II	1.26	\$63,000
Alder Ave.	Jurupa Ave.	San Bernardino Ave.	II	1.92	\$96,000
Armory Rd.	J St.	H St.	II	0.25	\$12,500
Arosa Dr.	Dart Canyon Rd.	North Rd.	II	1.17	\$58,500
Arrow Rte.	Hickory Ave.	Almeria Ave.	II	3.14	\$157,000
Aster Rd.	Mojave Dr.	Cactus Rd.	II	0.50	\$25,000
Baseline Rd.	0.02mi. E Conejo Dr.	Glasgow Ave.	II	0.24	\$12,000
Baseline Rd.	Perris Hill Rd.	Tippecanoe Ave.	II	0.08	\$4,000
Baseline Rd.	Yates St.	Del Rosa Dr.	II	0.06	\$3,000
Bear Springs Rd.	SR-18	SR-189	II	1.22	\$61,000
Beaumont Ave.	Bryn Mawr Ave.	Whittier Ave.	II	0.25	\$12,500
Bellflower St.	Mojave Dr.	Cactus Rd.	II	0.50	\$25,000
Benson Ave.	0.18mi. N Howard St.	State St.	II	0.34	\$17,000
Benson Ave.	Phillips Blvd.	0.06mi. N Howard St.	II	0.33	\$16,500
Bloomington Ave.	Cedar Ave.	Larch Ave.	II	0.40	\$20,000
C St.	0.07mi. W Jackson	0.07mi. E Tejon Ave.	II	0.48	\$24,000
Cactus Ave.	0.24mi. N Cricket Dr.	Slover Ave.	II	1.35	\$67,500
Cajon Blvd.	I-15	N of Palm Ave.	II	3.27	\$163,500
Cajon Blvd.	June St.	California St.	II	1.74	\$87,000

*NMTP - Revised June 2018 - County of San Bernardino*

Cajon Blvd.	Planned path NW of I-15	Planned path SE of I-15	II	0.90	\$900,000
Cajon Blvd.	Santa Fe Fire	I-15	II	7.46	\$373,000
California St.	0.02mi. S Redlands NB Only	Orange Ave.	II	0.76	\$38,000
California St.	Almond Ave.	Palmetto Ave.	II	0.75	\$37,500
Cedar Ave.	Bohnert Ave.	0.06mi. S Bohnert Ave.	II	0.06	\$3,000
Cedar Ave.	Randall Ave.	El Rivino Rd.	II	3.60	\$180,000
Central Ave.	State St.	Phillips Blvd.	II	0.83	\$41,500
Central Rd.	Las Tunas Dr.	Tussing Ranch Rd.	II	1.50	\$75,000
Central Rd.	Ocotillo Way	Mojave St.	II	0.37	\$18,500
Cherokee St.	0.9mi. W Harvard Rd.	Harvard Rd.	II	0.89	\$44,500
Cherry Ave.	Valley Blvd.	0.13mi. S Foothill Blvd.	II	2.38	\$119,000
Chino Ave.	SR-71	0.13mi. E Pipeline Ave.	II	1.10	\$55,000
Colton Ave.	Orange Blossom Trail/Wabash	Opal Ave.	II	0.25	\$12,500
Country Club Blvd.	Barranca Blvd.	Greenspot Rd.	III	0.07	\$1,130
Country Club Dr.	Spring Valley Pkwy.	Fortuna Ln.	II	1.25	\$62,500
Crafton Ave.	Anzio Ave.	5th Ave.	II	1.93	\$96,500
Crafton Ave.	San Bernardino Ave.	Anzio Ave.	II	0.05	\$2,500
Crest Forest Dr.	Crestline Rd.	SR-18	II	3.35	\$167,500
Daley Canyon Rd.	SR-189	SR-18	II	0.54	\$27,000
Del Rosa Ave.	Del Roas Dr.	Pacific St.	II	0.38	\$19,000
Del Rosa Ave.	Foothill Dr.	Eureka St.	II	0.38	\$19,000
Del Rosa Ave.	Marshall Blvd.	Date St.	II	0.40	\$20,000
Del Rosa Dr.	N of Del Rosa Ave.	Baseline Rd.	II	0.85	\$42,500
Division Dr.	Robinhood Blvd.	North Shore Dr.	II	0.42	\$21,000
Division Dr./McAlister Rd.	Robinhood Blvd.	Juniper Dr.	II	0.65	\$32,900
E St.	S of 49th St.	Hill Dr.	II	0.18	\$9,000
East End Ave.	Chino Ave.	Walnut Ave.	II	0.93	\$46,500
East End Ave.	Grand Ave.	Maxon Ln.	II	1.20	\$60,000
El Centro Rd.	Columbine Rd.	Oak Hill Rd.	II	0.12	\$6,000
El Evado Rd.	La Brisa Rd.	Anacapa Rd.	II	1.29	\$64,500
Electric Ave.	N of 40th St.	S of 44th St.	II	0.10	\$5,000
Etiwanda Ave.	Napa St.	I-10	II	1.52	\$76,000
Euclid Ave.	24th St.	Mountain Ave.	II	0.71	\$35,500
Fern Dr.	Crest Forest Dr.	Lake Dr.	II	0.41	\$20,500
Florida Ave.	Greenspot Rd.	Garnet Ave.	II	0.74	\$37,000
Fontana Ave.	Valley Blvd.	Lime Ave.	II	0.89	\$44,500
Foothill Dr.	Del Rosa Ave.	Sterling Ave.	II	0.50	\$25,000
Fortuna Ln.	Country Club Dr.	Yates Rd.	II	0.10	\$5,000
Fox Farm Rd.	0.11mi. W McAlister.	McAlister Rd.	II	0.10	\$5,000
Francis Ave.	0.11mi. W East End Ave.	0.13mi. E Telephone	II	1.99	\$99,500
Garnet Ave.	Florida Ave.	Redlands City Limit	II	0.59	\$29,500
Garnet Ave.	Redlands City Limit	SR-38	II	0.12	\$6,000
Ghost Town Rd.	I-15 Underpass	Yermo Rd.	II	0.15	\$7,500
Grand Ave.	East End Ave.	Ramona Ave.	II	0.96	\$48,000
Grass Valley Rd.	SR-189	SR-173	II	4.70	\$235,000
H St.	49th St.	40th St.	II	0.57	\$28,500
H St.	Rimrock Rd.	Linda Vista Ave.	II	1.00	\$50,000
Highland Ave.	Osburn Rd.	Sterling Ave.	II	0.25	\$12,500
Holcomb Valley Rd.	SR-38	N End	II	0.23	\$11,500

*NMTP - Revised June 2018 - County of San Bernardino*

Irwin Rd.	Old State 58	Radio Rd.	II	0.39	\$19,500
Joshua Rd.	Waalew Rd.	Yucca Loma Rd.	II	3.87	\$193,500
Joshua Rd.	Yucca Loma Rd.	Bear Valley Rd.	II	1.98	\$99,000
Jurupa Ave.	Locust Ave.	0.09mi. W Willow Ave.	II	1.90	\$95,000
Jurupa Ave.	Tamarind Ave.	Alder Ave.	II	0.25	\$12,500
Kuffel Canyon Rd.	SR-173	SR-18	II	1.23	\$61,500
Lake Dr.	SR-138	Dart Canyon Rd.	II	2.39	\$119,500
Lake Gregory Dr.	Lake Dr.	SR-189	II	2.21	\$110,500
Leona Rd.	Poplar St.	Old State 58	II	0.35	\$17,500
Live Oak Dr.	SR-330	SR-18	II	1.64	\$82,000
Loch Leven Rd.	SR-173	Cottage Grove Rd.	II	0.11	\$5,500
Locust Ave.	7th St.	11th St.	II	0.28	\$14,000
Locust Ave.	Jurupa Ave.	Randall Ave.	II	2.39	\$119,500
Lower Calico Acrd.	Calico Rd.	Cemetery Access	III	0.20	\$3,000
Main St.	0.19mi. NE Sweeten Ln.	0.07mi. E Western Dr.	II	1.16	\$58,000
Main St.	Hinkley Rd.	Delaney Rd.	II	3.20	\$160,000
Marshall Blvd.	Del Rosa Ave.	Sterling Ave.	II	0.50	\$25,000
Mentone Blvd.	Crafton Ave.	Bryant St.	II	4.31	\$215,500
Merrill Ave.	Cherry Ave.	Catawba Ave.	II	1.76	\$88,000
Mesquite Springs Rd.	Old Chisholm Trail	N of Rainier Rd.	II	0.49	\$24,500
Mesquite St.	Escondido Ave.	Topaz Ave.	II	1.00	\$50,000
Mill St.	W limit	National Trails Hwy	II	0.30	\$15,000
Mission Blvd.	0.07mi. W Central Ave.	Benson Ave.	II	0.56	\$28,000
Mission Blvd.	LA County	0.06mi. E Pipeline Ave.	II	0.37	\$18,500
Mojave Dr.	Aster Rd.	Mesquite Rd.-WB Only	II	1.51	\$37,750
Monte Vista Ave.	Francis Ave.	Howard Ave.	II	0.78	\$39,000
Mountain Ave.	23rd St.	Euclid Ave.	II	1.36	\$68,000
Naples Ave.	Wabash Ave.	Orange Blossom Trail	II	0.31	\$15,500
National Trails Hwy.	A St.	Goffs Rd.	III	120.00	\$1,800,000
National Trails Hwy.	Mill St.	Walton Rd.	II	0.64	\$32,000
Needles Hwy.	N City Limits	N County Limits	II	11.92	\$596,000
Nevada St.	Palmeto Ave.	Lugonia Ave.	II	0.99	\$49,500
North Bay Rd.	SR-173	Golden Rule Ln.	II	0.35	\$17,500
North Rd.	Lake Gregory Dr.	SR-189	II	2.14	\$107,000
Oak Hill Rd.	0.02mi. N Caliente Rd.	Mesquite St.	II	2.28	\$114,000
Ocotillo Way	Navajo Rd.	Central Rd.	II	0.99	\$49,500
Old State 58	0.06mi. W First St.	0.08mi. E Fern St.	II	2.04	\$102,000
Old State 58	0.13mi. E Dixie Rd.	Irwin Rd.	II	6.77	\$338,500
Old State 58	Irwin Rd.	0.02mi. W Camarillo Ave.	II	0.33	\$16,500
Olive St.	W Colton Hole	E Colton Hole	II	0.49	\$24,500
Opal Ave.	San Bernardino Ave.	Colton Ave.	II	1.05	\$52,500
Osdick Rd.	Randsburg CTF	US 395	II	0.60	\$30,000
Pacific St.	Dwight Way	Sterling Ave.	II	0.71	\$35,500
Palmetto Ave.	Nevada St.	Alabama St.	II	0.50	\$24,850
Park Blvd.	Twentynine Palms Hwy	Hill Top Dr.	II	0.50	\$25,000
Pelican Lake Trail	Park Entrance Rd.	Yates Rd.	I	0.50	\$500,000
Pepper Ave.	Valley Blvd.	Slover Ave.	II	0.49	\$24,500
Philadelphia St.	E of Ramona Ave.	W of Carlisle Ave.	II	0.33	\$16,500
Philadelphia St.	W County Limit	Norton Ave.	II	0.97	\$48,500

*NMTP - Revised June 2018 - County of San Bernardino*

Phillips Blvd.	Central Ave.	Benson Ave.	II	0.50	\$25,000
Phillips Blvd.	LA County	0.11mi. E Fremont Ave.	II	1.92	\$96,000
Pioneer Ave.	Alabama St.	Buckeye St.	I	1.33	\$1,340,000
Ramona Ave.	0.03mi. N Philadelphia Ave.	Grand Ave.	II	1.01	\$50,500
Ranchero Rd.	W Oak Hill Rd.	E Oak Hill Rd.	II	0.25	\$12,500
Randall Ave.	Alder Ave.	Cedar Ave.	II	1.25	\$62,500
Reche Canyon Rd.	Fern Ln.	Reche Canyon Rd.	II	0.29	\$14,500
Reche Canyon Rd.	Utility Access Rd.	Pepper Tree Ln.	II	0.72	\$36,000
Ridgecrest Rd.	0.16mi. south of Chinguapin	0.23mi. north of Chinguapin	I	0.39	\$390,000
River Rd.	Soto Ranch Rd.	Needles Hwy	II	3.65	\$182,500
Riverside Ave.	N Ayala Dr.	SE of Pecan Ave.	II	1.35	\$67,500
Riverside Dr.	Co E of Riverside Way	Co E of Pipeline Ave.	II	1.73	\$86,500
Riverside OH	SE of Peach St.	SE of Kauri Ave.	II	1.25	\$62,500
Rock Springs Rd.	E Hesperia City Limit	Mojave Riverwalk	II	0.22	\$11,000
San Antonio Ave.	San Antonio Crescent W & E	23rd St.	II	0.28	\$14,000
San Antonio Cres. W	Mountain Ave.	San Antonio Cres. E	II	0.21	\$10,500
San Bernardino Ave.	0.05mi. W Suffel St.	Crafton Ave.	II	0.62	\$31,000
San Bernardino Ave.	Alder Ave.	0.07mi. E Larch Ave.	II	1.56	\$78,000
San Bernardino Ave.	California St.	Redlands City Limit	II	1.34	\$67,000
San Bernardino Ave.	Etiwanda Ave.	Fontana Ave.	II	3.28	\$164,000
San Bernardino Ave.	Wabash Ave.	0.05mi. W Suffel St.	II	0.53	\$26,500
San Moritz Dr.	Lake Gregory Dr.	Arosa Dr.	II	1.60	\$80,000
San Timoteo Canyon Rd.	Barton Rd.	Nevada St.	II	0.44	\$22,000
Santa Ana Ave.	Cedar Ave.	Cactus Ave.	II	0.75	\$37,500
Santa Ana Ave.	Mulberry Ave.	Almond Ave.	II	0.77	\$38,500
Santa Ana Ave.	Tamarind Ave.	Cedar Ave.	II	1.50	\$75,000
Seneca Rd.	0.07mi. W Emerald Rd.	Amethyst Rd.	II	0.99	\$49,500
Shay Rd.	SR-38	0.07mi. E Barranca Blvd.	II	0.30	\$15,000
Slover Ave.	Cedar Ave.	Cactus Ave.	II	0.74	\$37,000
Slover Ave.	Mulberry Ave.	Almond Ave.	II	0.77	\$38,500
Slover Ave.	Tamarind Ave.	Cedar Ave.	II	1.50	\$75,000
Spring Valley Pkwy.	Vista Point Dr.	Huerta Rd.	II	1.39	\$69,500
SR-138	Waters Dr.	Lake Dr.	II	0.96	\$48,000
SR-173	Loch Leven Rd.	Kuffel Canyon Rd.	II	0.63	\$31,500
SR-18	Bear Springs Rd.	Daley Canyon Rd.	II	0.43	\$21,500
SR-18	Crest Forest Dr.	Lake Gregory Dr.	II	0.15	\$7,500
SR-189	North Rd.	Bear Springs Rd.	II	0.21	\$10,500
SR-189/Blue Jay CTF circle			II	0.90	\$45,000
SR-189/Lakes Edge Rd.	Blue Jay CTF	Loch Leven Rd.	II	1.78	\$89,000
Stanfield CTF	N of SR-18	SR-38	II	0.44	\$22,000
State St.	Highland Ave.	Cajon Blvd.	II	1.18	\$59,000
Sterling Ave.	Along Unicorp Portions N	Along Unicorp Portions S	II	1.53	\$76,500
Stoddard Wells Rd.	Johnson Rd.	Dale Evans Pkwy.	I	2.19	\$2,190,000



Sunburst Ave.	Joshua Tree Elementary School	2mi. N to Elementary School	I	2.67	\$2,670,000
Sunny Vista Rd.	Twentynine Palms Hwy.	Mt View Tr.	II	1.90	\$95,000
Tippecanoe Ave.	Vine St.	3rd St.	II	0.93	\$46,500
Topaz Rd.	Seneca Rd.	Palmdale Rd.	II	0.50	\$25,000
Trona Rd.	Community of Argus	Pinnacle Rd.	II	5.23	\$261,500
Trona Rd.	High School	Rest Stop	II	1.19	\$59,500
Trona Rd.	Inyo County Limit	Marshall St.	II	0.87	\$43,500
Trona Rd.	Marshall St.	High School	I	0.97	\$970,000
Trona Rd.	Rest Stop	Community of Argus	I	1.29	\$1,290,000
Trona Rd.	US 395	SR-178	II	21.14	\$1,057,000
Trona Rd. OH N	Center St.	E 16mi.	II	0.16	\$8,000
Tussing Ranch Rd.	Deep Creek Rd.	Kiowa Rd.	II	1.00	\$50,000
Valley Blvd.	Alder Ave.	Spruce Ave.	II	1.74	\$87,500
Valley Blvd.	Cherry Ave.	Hemlock Ave.	II	0.76	\$38,000
Valley Blvd.	Commerce Dr.	Mulberry Ave.	II	0.52	\$26,000
Valley Blvd.	Etiwanda Ave.	Commerce Dr.	II	0.49	\$24,500
Valley Blvd.	Mulberry Ave.	Almond Ave.	II	0.83	\$41,500
Valley Blvd.	W Colton Hole	E Colton Hole	II	0.43	\$21,500
Vista Point Dr.	Ridgecrest Rd.	Spring Valley Pkwy.	II	0.46	\$23,000
Vista Rd.	Lakeview Dr.	Jordan Rd.	II	1.32	\$66,000
Waalew Rd.	Joshua Rd.	0.03mi. E Tiama	II	0.44	\$22,000
Waalew Rd.	Meridian Ave.	E Limit	II	0.46	\$23,500
Walnut Ave.	0.1mi. W Roswell Ave.	Roswell Ave.	II	0.10	\$5,000
Waterman Ave.	6th St.	3rd St.	II	0.26	\$13,000
Waters Dr.	Crest Forest Dr.	SR-138	II	1.60	\$80,000
Yates Rd.	0.24mi. N Chinquapin Dr.	0.02mi. S Fortuna	II	1.35	\$67,500
			<b>Total</b>	<b>362.26</b>	<b>\$23,605,630</b>

The County of San Bernardino has not identified any priority improvements. When complete, the County will have constructed an additional approximately 360 miles of Class I, Class II and Class III, providing interregional connectivity to the residents of the County, including many of the County's rural residents.

Table 5.145

Priority Improvements

Street/Path	From	To	Class	Length (mi.)	Cost Estimate
n/a	n/a	n/a	n/a	n/a	n/a
			<b>Total</b>	<b>n/a</b>	<b>n/a</b>

**Development Code**

The County of San Bernardino has developed the following Development Codes related to non-motorized infrastructure

82.19.050 - Development Standards for Trails - The following standards shall be used to evaluate proposed trails:

<b>Item</b>	<b>Bicycle+ Pedestrian<sup>(1)</sup></b>	<b>Bicycle-only<sup>(1)</sup></b>	<b>Hiking-only</b>	<b>Equestrian-only<sup>(4)</sup></b>
Minimum width (one way)	10 ft.	5 ft.	5 ft.	8 ft.
Minimum width (two way)	12 ft.	8-10 ft.	8-10 ft.	10 ft.
Surface	Hardened, e.g. asphalt <sup>(2)</sup>	Hardened, e.g. asphalt	Hardened	Hard-packed, No paving
Shoulder	2 ft. minimum	2 ft. minimum	2 ft. minimum	2 ft. minimum
Vertical Clearance	12 ft.	10 ft.	10 ft.	12 ft.
Cross Slope	2% maximum	2% maximum	2% maximum	2% maximum
Maximum Grade	5%	5%	5%	Maximum limit is erosion control

<b>Item</b>	<b>Bicycle+ Pedestrian<sup>(1)</sup></b>	<b>Bicycle-only<sup>(1)</sup></b>	<b>Hiking-only</b>	<b>Equestrian-only<sup>(4)</sup></b>
Minimum width (one way)	6-8 ft.	2 ft.	2 ft.	6 ft.
Minimum width (two way)	8-10 ft.	2 ft.	4 ft.	8 ft.
Surface	Firm all weather and unobstructed	Minimize erosion	Minimize erosion	Minimize erosion
Shoulder	2 ft. minimum	2 ft. minimum	2 ft. minimum	2 ft. minimum
Vertical Clearance	10 ft.	8 ft.	8 ft.	12 ft.
Cross Slope	3% maximum	3% maximum	3% maximum	3% maximum
Maximum Grade	5%; rest and turning areas every 200 ft. minimum	Maximum limit is erosion control	Maximum limit is erosion control	Maximum limit is erosion control

**83.14.030 - Transportation Control Measures Development Standards**

- (a) Bicycle parking required. Bicycle parking facilities or secured bicycle lockers shall be provided for all non-residential and multi-family (of 10 or more units) developments when discretionary review is required. Parking racks or secured lockers shall be provided at a rate of 1 per 30 parking spaces with a minimum of a three-bike rack.
- (b) Pedestrian and bicycle connections to streets. On-site pedestrian walkways and bicycle facilities shall be provided connecting each structure in a development to public streets for all new non-residential and multi-family (of 10 or more units) development.

- (c) Shower facility. A minimum of one shower facility accessible to both men and women shall be provided for persons bicycling or walking to work for all new nonresidential development generating 250 or more peak hour trips.
- (j) Bicycle Plan. Participate in implementation of the Countywide Bicycle Plan (when adopted).

84.16.050 - Development Standards Applicable for Multi-Family Projects – Four to 19 Units

(g) Storage.

- (2) Bicycle/motorcycle storage area. All multi-family projects shall provide covered, enclosed, and secure storage areas for bicycles and motorcycles. Motorcycle spaces shall be at least four feet by eight feet.

87.05.030 – Dedications

(a) Streets, highways, and flood control rights-of-way.

- (2) In addition, the sub divider shall improve or agree to improve all streets, alleys, including access rights and abutters' rights, drainage, public utility easements and other public easements. The sub divider may also be required to dedicate the additional land as may be necessary and feasible to provide bicycle paths for the use and safety of residents of the subdivision.

87.06.050 Subdivision Improvement Requirements

- (a) Bicycle/walking paths and hiking/equestrian trails. Depending on the circumstances surrounding a specific project, the County may require, as a condition of approval, the sub divider to construct bicycle/walking paths and/or hiking/equestrian trails within an approved subdivision as determined by the review authority. In the event the review authority determines that path or trail construction within a subdivision would be infeasible or constitute unsound engineering, the review authority may grant the sub divider the option to pay into a fund, dedicated for these uses, the amount per foot, as determined by the review authority.

**End of Trip Facilities**

The County of San Bernardino has bike racks dispersed throughout the City, typically at retail centers, schools and multi-unit housing complexes.

**Multimodal Connectivity**

The County of San Bernardino has the following multimodal facilities that interface with the non-motorized transportation system.

Table 5.146

Multimodal Connections

Facility	Facility Type	Facility Location
Bloomington PNR	Ride Share Lot	10175 Cedar Rd
Crestline PNR	Ride Share Lot	Forest Shade & Lake Dr.
County-wide Bus Stops	Bus Stops	Throughout County

**Collisions Involving Bicyclists**

Table 5.147

Data for Collisions Involving Bicyclists

Parameter	Collision Rate
Total # of Bicycle Collisions from 2005-2009	182
Total # of Bicycle Fatalities from 2005-2009	9
Average # of Bicycle Collisions Per Year	36.4
Average Bicycle Collision Rate per 1000/year <sup>1</sup>	0.12

Notes:

1. Rate is calculated using SWITRS collision data and population figures by the California Department of Finance

**Safety and Education Programs**

The San Bernardino County Department of Public Health conducts safe walking and biking education and encouragement activities at elementary schools throughout the county with funds received under the federal Safe Routes to School program. The Department of Public Health also partners with the San Bernardino County Department of Public Works to conduct safe walking and biking workshops at elementary schools in conjunction with Safe Routes to School-funded infrastructure projects.

# SANBAG

## Population

2,076,274

## Subregion Overview

Table 5.148 represents an effort of SANBAG to establish non-motorized transportation connection between the San Bernardino Valley and the Victor Valley. The proposed path attempts to connect from Cajon Blvd. in San Bernardino County to Oak Hill Rd. in the City of Hesperia. The proposed area is currently in the jurisdiction of United States Forest Service (USFS) and the exact alignment of the path is yet to be determined.

Table 5.148

### SANBAG Future Improvements

Street/Path	From	To	Class	Length (mi.)	Cost Estimate
Santa Fe/USFS/Caliente Rd.	Cajon Blvd.	Oak Hill Rd.	I	10.13	\$10,130,000
			<b>Total</b>	<b>10.13</b>	<b>\$10,130,000</b>



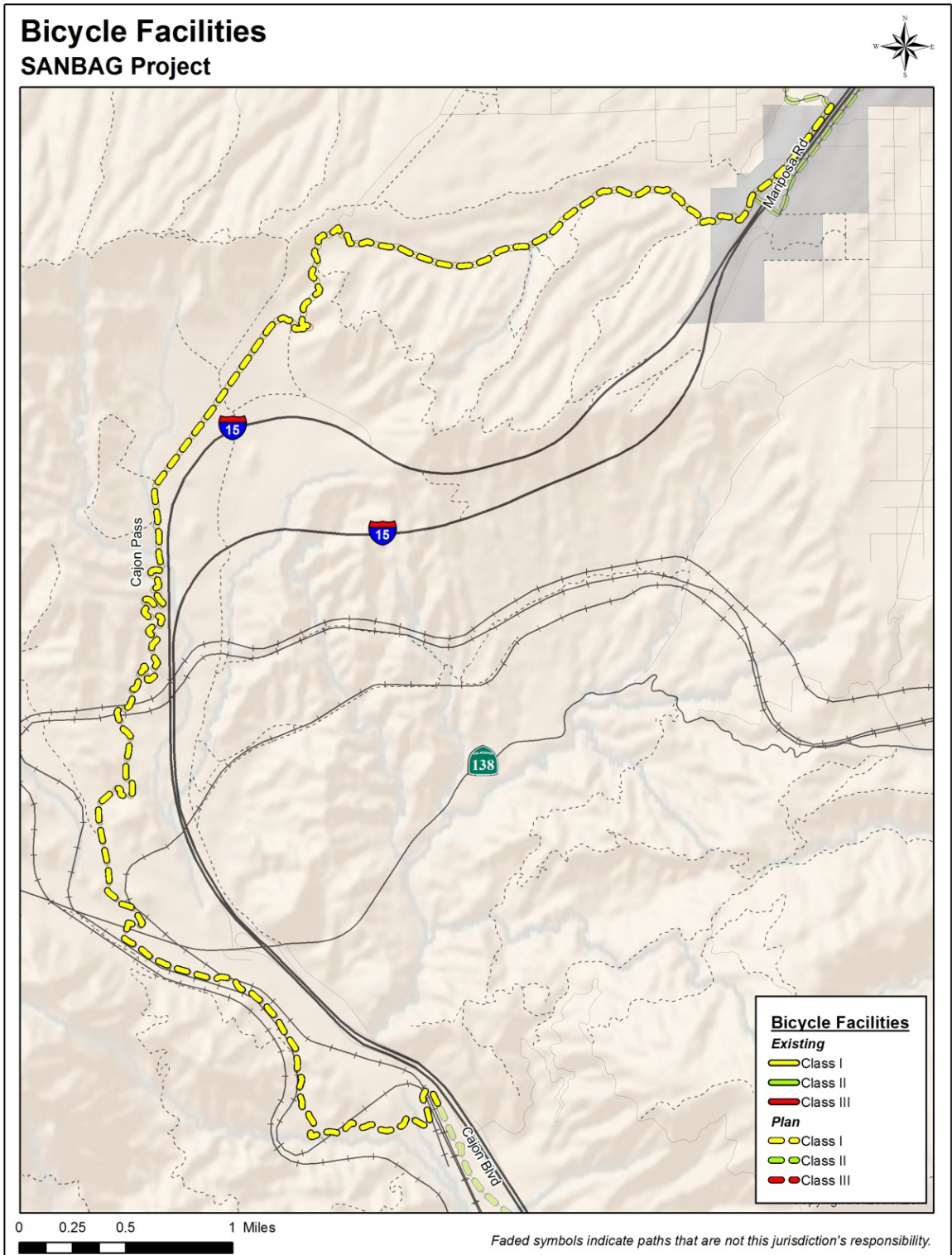

Figure 5.58

## 6.0 Design Guidelines

This chapter provides details on the recommended design and operating standards for the San Bernardino County Bikeway System.

The Caltrans Design Manual, Chapter 1000 – Bikeway Planning and Design establishes the standards for bicycle facility design within the state of California. These standards are, for the most part, consistent with the American Association of State Highway and Transportation Officials (AASHTO) Guidelines for the Development of Bicycle Facilities. The Caltrans standards provide the primary basis for the design recommendations that follow.

### 6.1 Definitions

The following section summarizes key operating and design definitions.

- **Bicycle:** A device, upon which any person may ride, propelled exclusively by human power through a belt, chain, or gears, and having two wheels in a tandem arrangement.
- **Class I Bikeway (Shared Use Path or Bike Path):** A bikeway physically separated from any street or highway. Shared Use Paths may also be used by pedestrians, skaters, wheelchair users, joggers, and other non-motorized users. For an example, see the figure immediately below.



Figure 6.1 – Class I Bikeway Information

**Class II Bikeway (Bike Lane):** A portion of roadway that has been designated by striping, signaling, and pavement markings for the preferential or exclusive use of bicyclists. For an example, see the graphics immediately below.



Figure 6.2 – Class II Bikeway Information

**Class III Bikeway (Bike Route):** A generic term for any road, street, path, or way that in some manner is specifically designated for bicycle travel regardless of whether such facilities are designated for the exclusive use of bicycles, or are to be shared with other transportation modes. For an example, see the graphics immediately below.



Figure 6.3 – Class III Bikeway Information

**Signed Shared Roadway or Signed Bike Route:** A shared roadway that has been designated by signing as a preferred route for bicycle use. These are Class III facilities under the Caltrans Design Standards.

**Class IV Bikeway (Separated Bikeway):** A Class IV bikeway is for the exclusive use of bicycles and includes a required separation between the bikeway and the through vehicular traffic. The separation may include, but is not limited to, grade separation, flexible posts, inflexible posts, inflexible barriers, or on-street parking. For an example, see the graphics immediately below



Figure 6.4 – Class IV Separated Bikeway Information

## 6.2 Bicycle Design Recommendations

The following guidelines present the recommended minimum design standards and other recommended ancillary support items for shared use paths, bike lanes, and signed shared roadways. All bikeways should meet minimum Caltrans/AASHTO standards and/or the Manual on Uniform Traffic Control Devices (MUTCD). Where possible, it may be desirable to exceed the minimum standards for bike paths or bike lane widths, signage, lighting, and traffic signal detectors. In cases where Caltrans and AASHTO guidelines conflict, Caltrans Design Standards will take precedence.

### 6.2.1 Class I Bike Path Facilities

1. All shared use paths should generally conform to the design recommendation by Caltrans/AASHTO/MUTCD.
2. Class I bike paths should generally be designed as separated facilities away from parallel streets. They are commonly planned along rights-of-way such as waterways, utility corridors, flood control access roads, railroads, and the like that offer continuous separated riding opportunities. Special signage to separate different uses may be installed as per MUTCD guidelines seen in the figure below.



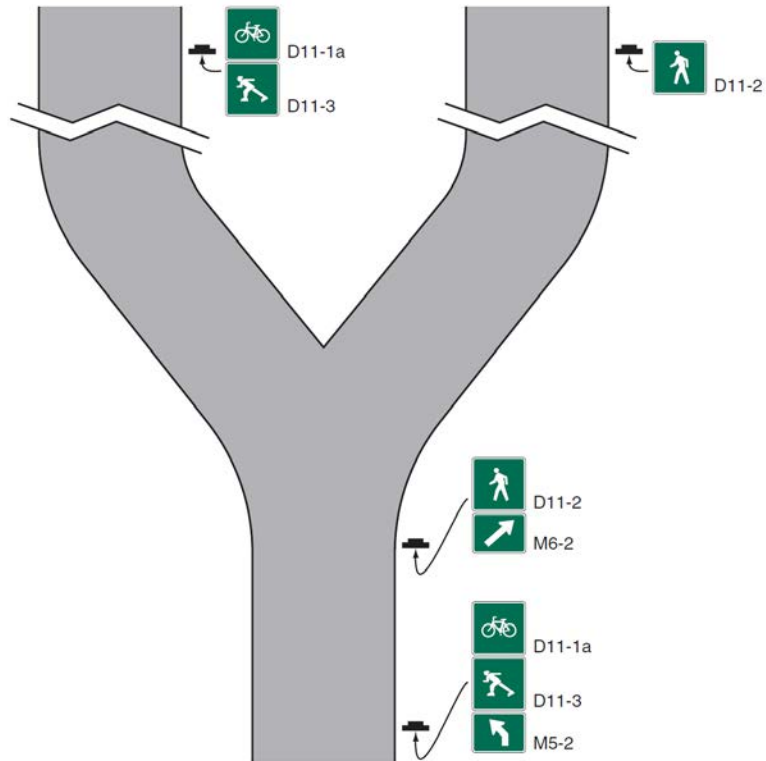

Figure 6.5 – Mode-specific Guide Signs for Shared-use Paths

3. Bike paths should have a minimum of eight feet of pavement, with at least two feet of unpaved shoulders for pedestrians/runners, or a separate tread way where feasible. Paved width of twelve feet is preferred. Direct pedestrians to right side of pathway with signing and/or stenciling.
4. Multi-use trails and unpaved facilities that serve primarily a recreation rather than a transportation function and will not be funded with federal or state transportation dollars may not need to be designed to Caltrans/AASHTO/MUTCD standards.
5. Both AASHTO and Caltrans recommend against using most sidewalks for bike paths. This is due to conflicts with driveways and intersections. Where sidewalks are used as bike paths, they should be placed in locations with few driveways and intersections, should be properly separated from the roadway, and should have carefully designed intersection crossings.
6. Shared use path crossings of roadways require preliminary review. A prototype design is presented in the abovementioned Definitions section.
7. Crossings of roadways, other than at intersections, should be carefully engineered to accommodate a safe and visible crossing for users. The design needs to consider the width of the roadway, whether it has a median, and the roadway's average daily and peak-hour traffic volumes. Crossings of low-volume streets may require simple stop signs. Generally speaking, bike paths that cross roadways with Average Daily Trips



(ADTs) over 15,000 vehicles will require signalization, grade separation, flashing LED beacons, crossing islands, other devices, or a combination of such features. Roundabouts can provide desirable treatment for a bike path intersecting with roadways where the bike path is not next to a parallel street.



Figure 6.6 – Combined Bike/Pedestrian Crossing Sign

8. Landscaping should generally consist of low water-consuming native vegetation and should have the least amount of debris.
9. Lighting should be provided where commuters will likely use the bike path in the evenings.
10. Barriers at pathway entrances should be clearly marked with reflectors and be ADA accessible (minimum five feet clearance).
11. Bike path construction should take into account vertical requirements, the impacts of maintenance, and emergency vehicles on shoulders.
12. Provide adequate trailhead parking and other facilities such as restrooms, and drinking fountains at appropriate locations.

### 6.2.2 Class II Bike Lane Facilities

The following guidelines should be used when designing Class II bikeway facilities. These guidelines are provided by the Caltrans Highway Design Manual, Chapter 1000, AASHTO, MUTCD, and the Caltrans Traffic Manual.

1. Class II Bike Lane facilities should conform to the minimum design standard of five feet in width in the direction of vehicle travel adjacent to the curb lane. Where space is available, a width of 6 to 8 feet is preferred, especially on busy arterial streets, on grades, and adjacent to parallel parking.

2. Under certain circumstances, bike lanes may be four feet in width. Situations where this is permitted include the following.
  - Bike lanes located between through traffic lanes and right turn pockets at intersection approaches. See Figure 6.8.
  - Where there is no parking, the gutter pan is no more than 12” wide, and the pavement is smooth and flush with the gutter pan.
  - Where there is no curb and the pavement is smooth to the curb.
3. “Bike Lane” signage, as shown directly below, shall be posted after every significant intersection along the route of the bike lane facility. Directional signage may also accompany this sign to guide bicyclists along the route. If a bike lane exists where parking is prohibited, “no parking” signage may accompany bike lane signage.



Figure 6.7 – Bike Lane Sign

4. Bike lanes should be striped with a solid white stripe of width at least 4 inches and may be dashed up to 200 feet before the approach to an intersection. This design of a dashed bike lane allows for its dual use as a right-turn pocket for motor vehicles.
5. Stencils shall also be used within the lane on the pavement that read “bike lane” and include a stencil of a bicycle with an arrow showing the direction of travel. See the figure below.



Figure 6.8 – Bike Lane Markings

6. Bike lanes with two stripes are more visible than those with one and are preferred. The second stripe would differentiate the bike lane from the parking lane where appropriate.
7. Where space permits, intersection treatments should include bike lane 'pockets' as shown in the figure below.



Figure 6.9 – Bike Lane Pocket

8. Loop detectors that detect bicycles should be installed near the stop bar in the bike lane at all signalized arterial/arterial, arterial/collector, and collector/collector intersections where bicycles are not reasonably accommodated. The location of the detectors should be identified by a stencil of a bicycle and the words "Bicycle Detector". Signal timing and phasing should be set to accommodate bicycle acceleration speeds. Please see the figure below.

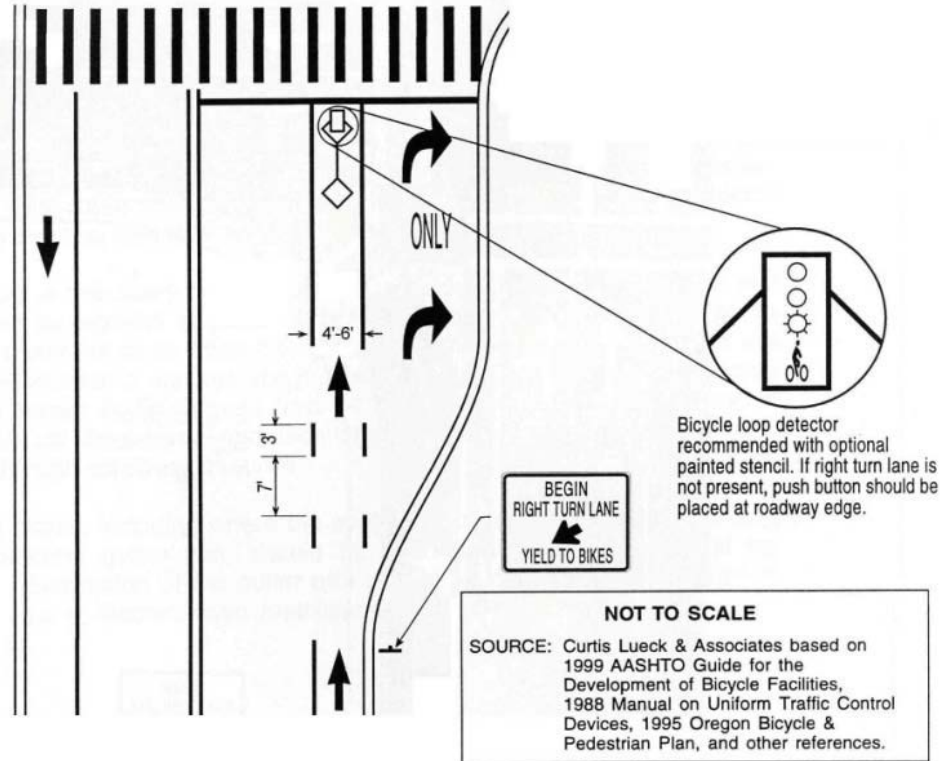

Figure 6.10 – Bike Lane Treatments at Intersection

9. Bicycle-sensitive loop detectors are preferred over a signalized button specifically designed for bicyclists.
10. Bike lane pockets between right turn lanes and through lanes should be provided wherever available width allows and where right turn volumes exceed 150 motor vehicles per hour.
11. Where bottlenecks preclude continuous bike lanes, they should be linked with bikeway route treatments.

### 6.2.3 Class III Bike Route Facilities

Bike routes have been typically designated as simple signed routes along street corridors, usually local streets and collectors, and sometimes along arterials. With proper route signage, design, and maintenance, bike routes can be effective in guiding bicyclists along a route suited for bicycling without having enough roadway space to provide a dedicated Class II bike lane.

Class III Bike Routes can be designed in a manner that encourages bicycle usage, convenience, and safety. There are a variety of other improvements that can enhance the safety and attraction of streets for bicyclists. Bike routes can become more useful when coupled with such techniques as the following:

- Route, directional, and distance signage

- Wide curb lanes
- Sharrow stencils painted in the traffic lane along the appropriate path of where a bicyclist would ride in the lane
- Accelerated pavement maintenance schedules
- Traffic signals timed and coordinated for cyclists (where appropriate)
- Traffic calming measures

The following design guidelines should be used with the implementation of new Class III Bike Route facilities in the SANBAG region.

### Signage

Proper “Bike Route” signage, as shown in the figure below, should be posted after every intersection along the route of the bikeway. This will inform bicyclists that the bikeway facility continues and will alert motorists to the presence of bicyclists along the route. Directional signage may accompany this sign as well to guide bicyclists along the route.



Figure 6.11 – Bike Route Sign

The sharrow stencil is a way to enhance the visibility and safety of new Class III Bike Route facilities. The stencil should be placed outside of on-street vehicle parking to encourage cyclists to ride away from parked cars’ open doors. They should also be placed at one or two locations on every block. See below.



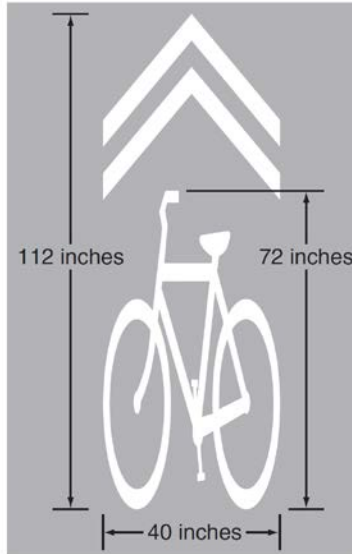

Figure 6.12 – Sharrow Stencil Guidelines

In the case where a lane is too narrow for motorists and cyclists to operate side-by-side, the following sign can be used.



Figure 6.13 – Full Lane Shared Use Sign

### Bicycle Boulevards

Bicycle boulevards are Class III bikeways that prioritize bicycles through the use of diverters and other traffic controls. Bicycle boulevards are to be implemented on local streets, generally with fewer than 3,000 vehicles per day, through a combination of traffic calming, intersection treatments, and signing. Bicycle lanes (Class II) are normally not used on a bicycle boulevard, thus little or no parking removal is proposed. The implementation of bicycle boulevards should not result in significant traffic diversion onto other local streets.

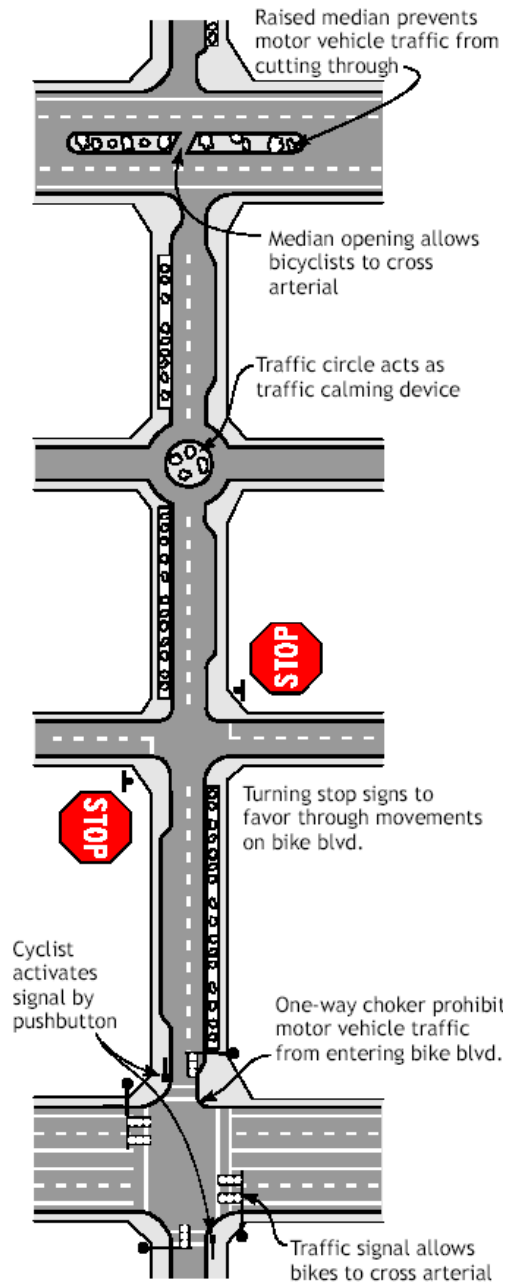

Figure 6.14 – Bike Boulevard Specifications

Bicycle boulevards are most effective when a grid system is in place so motor vehicles can use a parallel route and cyclists can follow a bike boulevard to within a block or two of their destination. Special bicycle stencils, signs, and road treatments are used on bicycle boulevards, as seen in the figure above. Stop signs are often turned on these roadways to prevent cyclists from having to stop at each intersection, and signals are installed at busy intersections to allow safe cyclist crossings.

## 6.2.4 Class IV Separated Bikeway Facilities

Design elements for these facilities are provided from Caltrans DIB 89-01. Further guidance can be found in CA MUTCD, Caltrans Highway Design Manual (HDM), and the California Vehicle Code (CVC) where noted. The design criterion is presented graphically in subsection 6 here under this subheading.

### 1. Vertical Element Separations

*The bikeway vertical element separation shall be at least one of the following to discourage the intrusion of motor vehicles into the bikeway:*

- a. Grade Separation: A vertical alignment that is on a different elevation from the adjacent roadway. The horizontal alignment may also be separate from the roadway.
- b. Flexible Posts: Class 1 Flexible Posts or similar. See the CA MUTCD Part 3. A 10-foot to 20-foot on center spacing should be used.
- c. Inflexible Physical Barrier: Barrier, railing, landscape planters or similar. A 10-foot to 20-foot on center spacing or continuous inflexible physical barrier should be used. These items should include signs/markers per the CA MUTCD Part 2.
- d. On-Street Parking: Parking allowed all times of the day, except for maintenance. If continuous inflexible physical barriers, raised island or curb/dike are used in the buffer, an opening should be such that a 5-foot minimum clear width is provided for pedestrians to access their vehicle and the sidewalk. Also, this placement should be designed to accommodate drainage. In the case of a separated bikeway on a hill, a curb or dike is required in order for the wheels of parked vehicles to be turned against, per CVC 22509.
- e. Raised Island: Raised channelization islands that may include landscaping and signs/markers per the CA MUTCD Part 2. Curb, dike or wheel stops (i.e., parking bumpers) may also be used. Drainage design for runoff is also needed.

### 2. Separation Width

*The separation includes a width or buffer:*

- a. Grade Separation: For a separated bikeway on the same grade as a sidewalk, the separated bikeway separation width should be 1.5 feet minimum including the curb width (which may include landscaping), and 3 feet minimum with parking to account for vehicle doors. Note, this portion of the sidewalk can no longer be used by pedestrians. If the separated bikeway is in the roadbed and is raised, the vertical taper occurs in the buffer between the separated bikeway and the vehicular traffic lanes. The vertical taper is included in the buffer width of 3 feet preferred, with 2 feet being the minimum where there is no parking. With parking this width should be 3 feet minimum and 5 feet with accessible parking. If no parking, the buffer includes either flexible posts, inflexible physical barrier or a raised island because the vertical taper itself may be too subtle to be recognized by drivers; these are not required with parking. See below for raised separated bikeway and vertical taper guidance.

- b. Flexible Posts: The flexible posts should be placed in the center of a marked buffer that is 3 feet wide preferred, with 2 feet being the minimum width. For the separated bikeway on a sidewalk, the separation may include the flexible posts 1.5 feet minimum from face of curb.
- c. Inflexible Physical Barrier: An inflexible physical barrier should be used in lower speed environments (where the posted speed is 35 miles per hour or less). An inflexible physical barrier should be placed in a marked buffer of 3 feet wide preferred, with 2 feet minimum width. In higher speed environments a concrete barrier should be used. On a sidewalk, the separation may include the inflexible physical barrier 1.5 feet minimum from face of curb.
- d. On-Street Parking: A marked buffer between the on-street parking and the separated bikeway should be a minimum width of 3 feet. However, at on-street accessible parking the minimum width is 5 feet. The flexible posts, inflexible physical barrier or raised island may be included.
- e. Raised Island: Raised islands may be between the separated bikeway and vehicular traffic or parking. These should be 3 feet preferred if no parking is allowed, with 2 feet being the minimum width; 1-foot if used with flexible posts. Three feet is the minimum width with parking; 5 feet with accessible parking.

### 3. Separated Bikeway Width

*Separated bikeway width is designated by the clearance between markings, inflexible physical barriers, bridge barriers or railings, and curbs. Also, consideration for maintenance, such as street sweeping, snow removal, and debris removal from de-icing practices should be part of the decision for the width selected. Anticipated bicycle volume, need for passing, bicycle commuting route, and availability of right-of-way are some of the factors where the separated bikeway width may exceed the minimum or preferred stated below:*

- a. The separated bikeway clear width should be 7 feet preferred, with 5 feet being the minimum width for one-way travel when adjacent to a roadway. For two-way travel, the same width as a Class I Bikeway (bike path) should apply. On a structure, the same width as a Class 1 Bikeway should also apply. See HDM Index 1003.1 for more information. When located at accessible parking or a bus stop, the separated bikeway minimum width should be 4 feet. See the CA MUTCD Part 9 for additional guidance on longitudinal pavement markings and the symbol marking.

#### 4. Separated Bikeway Approach Tapers

*Separated bikeway approach tapers will occur primarily at intersections, but may occur at other locations depending on the presence of traffic signal hardware, etc. For example, reducing the separated bikeway width may be required due to the presence of accessible parking, bus stops, or transit stations:*

- a. A 10:1 separated bikeway approach taper transition is preferred, with 5:1 being the minimum.

#### 5. Raised Separated Bikeways

*If the separated bikeway is to be raised, it should be designed to accommodate drainage. Also, the transition from the bikeway to the roadway may be designed to allow the bicyclist to enter the adjacent traffic lanes:*

- a. A raised separated bikeway should be elevated 3 inches minimum above the finished grade, but no higher than the adjacent curb in order to allow drainage towards the street unless some other drainage design is implemented.
- b. A vertical tapered edge should be 4:1 or flatter occurring in the marked buffer.



6. Design Elements Diagram

**Typical Class IV Bikeway (Separated Bikeway) Cross Sections**

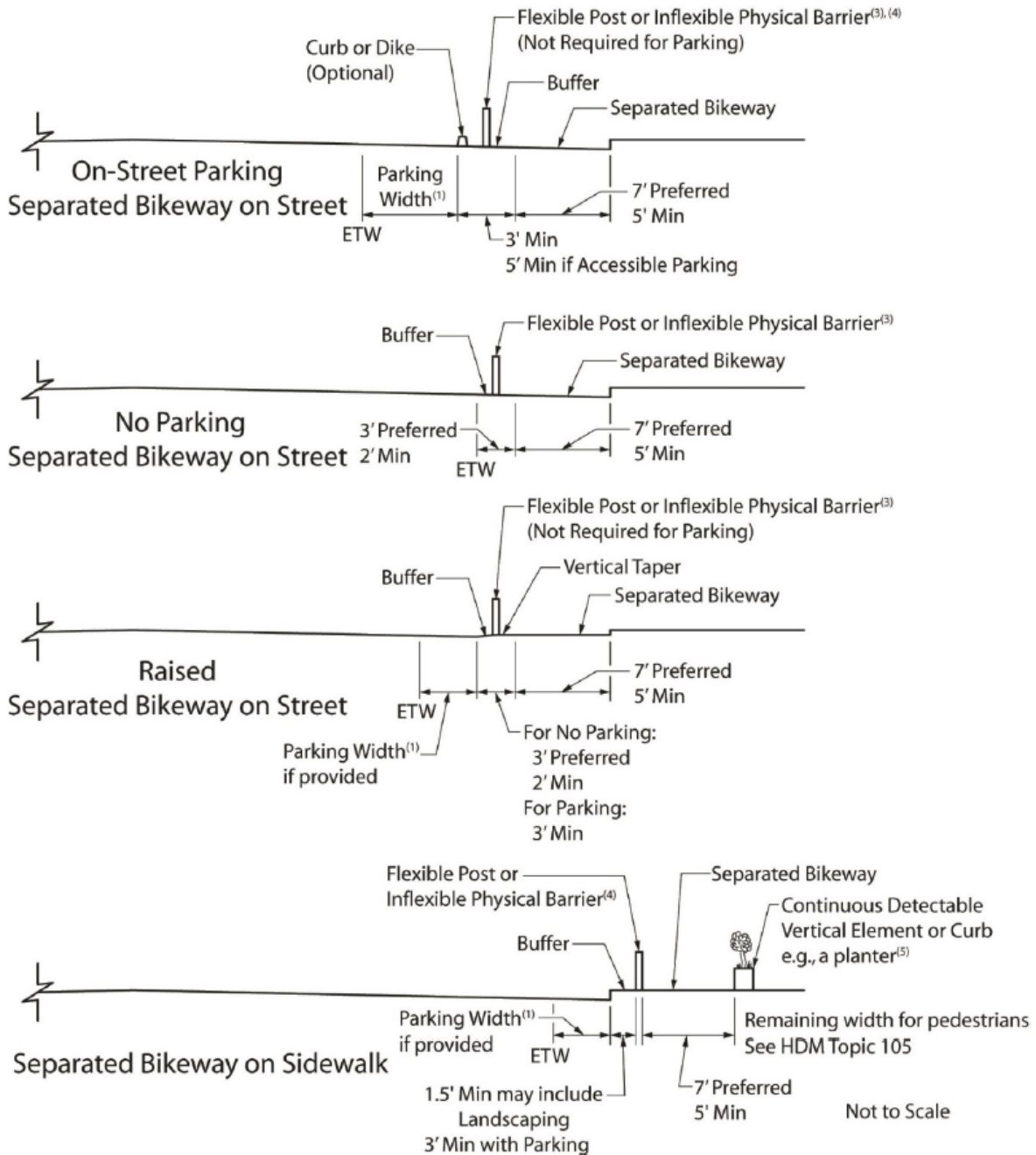

**NOTES:**

- (1) See CA MUTCD Section 3B.19 for parking guidance.
- (2) For separated bikeway marking and signing guidance, see the CA MUTCD Part 9.
- (3) May be a raised island in lieu of flexible posts or inflexible physical barriers.
- (4) Flexible posts or inflexible physical barriers may be omitted.
- (5) Periodic openings should be provided for bicyclists to access buildings.

## 6.2.5 Numbering Bikeways

A numbered bike route network may be devised as a convenient way for bicyclists to navigate through the valley much the way the numbered highway system guides motorists efficiently through the roadway network. This could be used on all classes of bikeways. An example of a numbered bikeway sign is shown in figure below.



Figure 6.15 – Numbered Bikeway Signs

Destination signs add value to bike routes and assist cyclists to develop a mental map of the route system. Arrows pointing to “Downtown,” “Mojave Narrows Regional Park - 2.5 miles” or “CSU – San Bernardino” should be a standard part of the bikeway network. Destination signs should be placed at the intersection of bikeways to notify cyclists where each bike route goes.

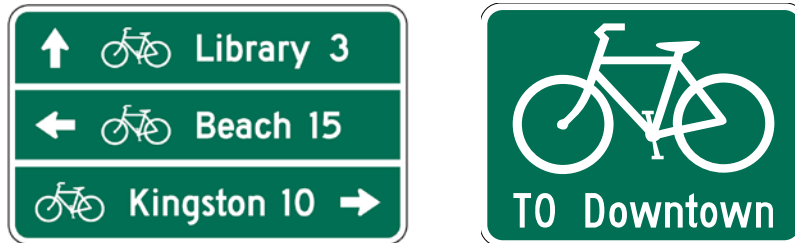

Figure 6.16 – Bicycle Destination Signs

## 6.2.6 Rumble Strips

Rumble strips are provided to alert motorists that they are wandering off the travel lanes onto the shoulder. They are most common on long sections of straight freeways in rural settings, but are also used on sections of two-lane undivided highways. Early designs placed bumps across the entire width of the shoulder, which is very uncomfortable for cyclists.

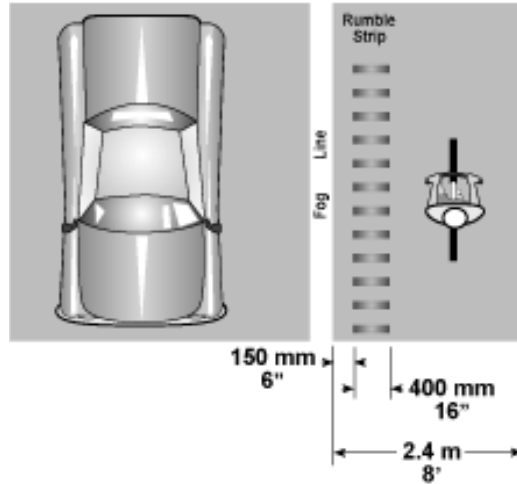

Figure 6.17 – Rumble Strip

A newer rumble strip design is more bicycle-friendly: 400 mm (16") grooves are cut into the shoulder, 150 mm (6") from the fog line. On a 2.4 m (8 ft) shoulder, this leaves 1.8 m (6 ft) of usable shoulder for bicyclists.

### 6.2.7 Drainage Gates

Care must be taken to ensure that drainage gates are bicycle-safe. If not, a bicycle wheel may fall into the slots of the grate causing the cyclist to fall. Replacing existing grates or welding thin metal straps across the grate perpendicular to the direction of is required. These should be checked periodically to ensure that the straps remain in place.

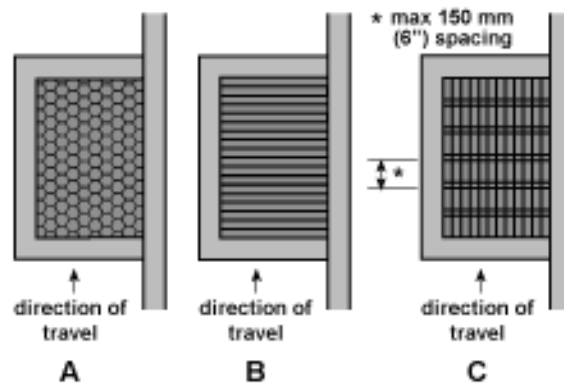

Figure 6.18 – Bike Safe Grates

The most effective way to avoid drainage-grate problems is to eliminate them entirely with the use of inlets in the curb face (type CG-3).

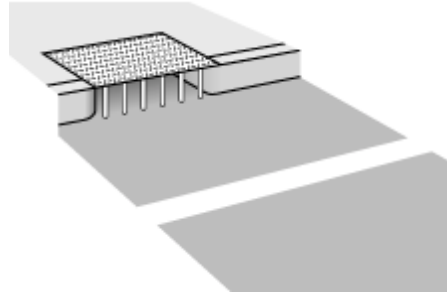

Figure 6.19 – Inlet Flush in the Curb Face

If a street-surface grate is required for drainage (types G-1, G-2, CG-1 and CG-2), care must be taken to ensure that the grate is flush with the road surface.

Inlets should be raised after a pavement overlay to within 6 mm (1/4") of the new surface. If this is not possible or practical, the pavement must taper into drainage inlets so they do not cause an abrupt edge at the inlet.

### 6.2.8 Extruded Curbs

These create an undesirable condition when used to separate motor vehicles from cyclists: either one may hit the curb and lose control, with the motor vehicle crossing onto the bikeway or the cyclist falling onto the roadway. At night, the curbs cast shadows on the lane, reducing the bicyclist's visibility of the surface. Extruded curbs make bikeways difficult to maintain and tend to collect debris. They are often hit by motor vehicles, causing them to break up and scatter loose pieces onto the surface.

### 6.2.9 Reflectors & Raised Pavement Markers

These can deflect a bicycle wheel, causing the cyclist to lose control. If pavement markers are needed for motorists, they should be installed on the motorist's side of the stripe, and have a beveled front edge. The use of raised pavement markers has been restricted or prohibited by several jurisdictions in recent years, including Washington State. Provisions can be made for their use in certain circumstances, including lane tapers, on uphill edgelines with 50' separation between installations, and where a specific engineering study concludes that the benefit of the installation to correct a demonstrable problem at a given site.

### 6.2.10 Sidewalks as Bicycle Facilities

The use of sidewalks as bicycle facilities is not encouraged by AASHTO, even as a Class III bike route, and may be completely illegal in some jurisdictions across the country. There are exceptions to this rule: while in residential areas, it is true that sidewalk riding by young children too inexperienced to ride in the street is common. With lower bicycle speeds and lower auto speeds, potential conflicts are somewhat lessened, but still exist. But it is inappropriate to sign these facilities as bikeways. Bicyclists should not be encouraged (through signing) to ride facilities that are not designed to accommodate bicycle travel.

Sidewalks can be used for short distances to make connections between off-street shared use paths and other facilities when such routing provides safer and more direct access than other available options.

### 6.2.11 Roadway Shoulder Evaluation

In areas where roadways have or will be developed with full curb and gutter, the provision of bikeways most often takes the form of striped bike lanes or signed bike routes. On roadways without curb and gutter, which is most often either a county or state road or highway in a rural, unincorporated, or developing area, shoulders provide both a place for bicyclists but also often for pedestrians and a breakdown lane for motor vehicles.

Many roads in the County, especially older roads and those carrying moderate to low traffic volumes, have little or no shoulders. Modern highways and newer roads are typically constructed with shoulders meeting current standards. It is the roadways with no or limited shoulders that present a challenge to local jurisdictions. The major obstacle to retrofitting these roads with adequate shoulders is cost, which in turn is related to:

1. the high number of road miles in the County,
2. the presence of adjacent drainage ditches, utility poles, and other obstacles making construction expensive,
3. lack of right of way, in some cases, and
4. the need to reconstruct roadways to give the shoulder structural integrity.

### 6.2.12 Shoulder Width

The width of a new or retrofitted shoulder is, in some cases, different for motor vehicle safety than for bicycle safety. For example, while a 3 meter wide (9.8 feet) shoulder is often preferable for vehicle safety, 1.2 meter (4 feet) wide shoulders are often sufficient for bicycle use. According to AASHTO, the most important features to provide for bicyclists on roadways are:

- Paved shoulders
- Wide outside traffic lane (4.2m minimum) if no shoulder
- Bicycle-safe drainage grates
- Adjusting manhole covers to the grade
- Maintaining a smooth, clean riding surface

The widened shoulder will generally be more accommodating in rural circumstances. Where it is intended that bicyclists ride on shoulders, smooth paved shoulders should be provided and maintained. Shoulder width should be a minimum of four (4) feet wide (1.2 meters) when intended to accommodate bicycle travel. Adding or improving shoulders can often be the best way to accommodate bicyclists in rural areas, and they also benefit motor vehicle traffic.

Shoulders constructed for motor vehicle purposes obviously will also benefit bicyclists. This section addresses the provision of shoulders to benefit bicyclists, which means that they (a) may or may not be constructed as part of a roadway paving or repaving project, (b) should be on those segments of the State Bicycle System offering the greatest benefit to bicyclists, and (c) will also benefit motorists and therefore not necessarily funded strictly with bicycle funds. In other words, shoulders will always benefit bicyclists and motor vehicles, and should be considered joint projects. Bicycle funds should be used on shoulders where they provide the greatest benefits to bicyclists.



Several other issues are important to address in relationship to shoulder improvements. First, while shoulders can frequently be widened, narrow bridges represent a potentially worse hazard because there is no escape zone for bicyclists or vehicles. Second, while shoulders always benefit bicyclists, they are especially critical in areas where there is limited motorist visibility, such as around sharp curves, where a vehicle will be surprised to find a bicycle in the roadway. Third, shoulders are always the repository of gravel and debris swept naturally by vehicle traffic, and need to be maintained on a routine basis to be usable by bicyclists. Fourth, in some cases shoulders can be 'created' simply by re-striping the existing pavement, narrowing travel lanes, or shifting lane striping. Finally, in some special circumstances, parallel pathways may supplement (but not replace) shoulders for bicycle traffic.

Wherever possible, new roadway shoulders should be constructed to AASHTO standards. AASHTO identifies a shoulder width of 3 meters (9.8 feet) for roadways with higher traffic volumes. "In difficult terrain and on low-volume highways, (...) the minimum shoulder width of .6 meters (about 2 feet) should be considered and a 1.8 to 2.4 meter width (5.9 feet to 7.8 feet) would be preferable." (p. 338). However, the cost to retrofit many of the state highways in California (and San Bernardino County), especially given the rugged topography and high number of road miles, means that narrower shoulders are a more practical solution. In areas of rugged topography or other constraints, wide shoulders are simply not practical except where there are appreciable traffic volumes. The final decision on shoulder width rests with the reasonable judgment of a licensed engineer.

Any additional shoulder width, even if it is .6 meter (about 2 feet), will benefit bicyclists. In some very constrained areas, or where motor vehicle and bicycle traffic is expected to be low, minimal shoulders between .6 and 1.2 meters (2 and 4 feet) in width are preferable to no shoulders.

### Categories of Improvements

While there are a wide variety of roadway settings that have a major impact on cost and feasibility of shoulders, there are four basic categories that describe the range of shoulder improvements (see Figures 5.1, 5.2, and 5.3). It is assumed that all new roadways or roadways with curb and gutter in developed areas will be developed as bike lanes or signed bike routes.

#### Type 1: New 1.2 meter (4 feet) wide shoulders

Constructed in relatively level terrain, no right of way needed, minor ditch relocation, and minor utility pole relocation. Includes new sub-base, new striping, pavement, striping, and signing.

Cost: \$150,000/mile

#### Type 2: New 1.2 meter (4 feet) wide shoulders

Constructed in moderate terrain, some moderate cuts and fills, some drainage ditch and utility relocation, new striping, and no right of way required.

Cost: \$350,000/mile

#### Type 3: New 0.6 to 1.2 meter (2 to 4 feet) wide shoulders

Constructed in rugged terrain, extensive grading, some new retaining wall, new striping, guardrails, no right of way required, and moderate utility and drainage ditch relocation or improvements.

Cost: \$700,000/mile

Type 4: Road Reconstruction to 9.6 meters (32 feet) with minimum 1.2 meter (4 feet) wide shoulders

Where a roadway warrants improvements based on traffic volumes or is being re-constructed due to structural deficiencies, the entire roadway will be constructed rather than simply adding shoulders of any width. While this is a costly approach and would probably be funded as part of a larger roadway project, it avoids long term problems with settling between the roadway and shoulder that can pose a hazard to bicyclists. Cost estimate assumes level to moderate terrain, with no right of way required but some utility and drainage ditch relocation.

Cost: \$500,000/mile

## Cost

Cost is the single limiting factor to constructing roadway shoulders. Cost in turn is directly related to the adjacent terrain, utilities, drainage ditches, and other constraints. While it is possible to develop an “average” shoulder cost for the local jurisdictions, the actual cost can be broken down into four basic categories for more accurate cost estimating. The estimated cost by category is listed identified above.

To develop an average cost for shoulder improvements, some assumptions must be made about the breakdown between the categories listed above. For planning purposes, this is assumed to be:

- Type 1: 50%
- Type 2: 20%
- Type 3: 20%
- Type 4: 10%

Given these assumptions, the average shoulder improvement cost per mile is estimated to be \$335,000.

Individual cost components are shown in Table 2. As can be seen, cost items such as bridges, earth excavation, and drainage can greatly impact the cost of a specific project.

## 6.2.13 Traffic Calming Programs

Traffic calming includes any effort to moderate or reduce vehicle speeds and/or traffic volumes on streets where that traffic has a negative impact on bicycle or pedestrian movement. Because these efforts may impact traffic outside the immediate corridor, study of traffic impacts is typically required. For example, the City of Berkeley, CA instituted traffic calming techniques by blocking access into residential streets. The impact was less traffic on local streets, and more traffic on arterials and collectors. Other techniques include installing traffic circles, intersection

islands, partial street closings, 'bulb-out' curbs, pavement treatments, lower speed, signal timing, and narrowing travel lanes.

Many cities in California already have a relatively continuous street grid system with little filtering of through traffic into residential neighborhoods. Traffic circles, roundabouts, and other measures may be considered for residential collector streets where there is a desire to control travel speeds and traffic volumes but not to install numerous stop signs or traffic signals.

Traffic calming alternatives should be considered where traffic speeds are exceedingly high, and when safety is an issue.

## 6.3 Emerging Innovations

Within the past decade, many jurisdictions across the nation are experimenting with and are considering specially designed roadway treatments and traffic signals, new methods of bicycle parking, and other innovations to encourage bicycling and make it safer. This section describes these innovations, including those in use in California as well as those from other parts of the country and world that could have promising applications in San Bernardino County.

### 6.3.1 Bicycle Boxes

The bike box is an intersection improvement design to prevent bicycle/car collisions, especially between drivers turning right and bicyclists going straight. It is a striped or colored box on the end of the road with a white bicycle symbol inside and includes bicycle lanes approaching the box. Cyclists stop in the bike box to be more visible while they wait for the signal. This waiting area – in front of motor vehicles, but behind the crosswalk – is typically painted a contrasting color. In order to provide maximum safety to bicycles, cars at these intersections are prohibited from making right-hand turns on red.



Figure 6.20 – Bicycle Box

Bicycle boxes increase safety by preventing a common collision at intersections known as the “right hook” where a vehicle making a right turn hits a cyclist proceeding straight through the intersection. Bike boxes are widely used in Europe and a few American cities have started to install them, including Portland, OR, San Luis Obispo, CA, and Long Beach, CA.

### 6.3.2 Contra-flow Bicycle Lanes

Contra-flow bicycle lanes allow bicyclists to travel in the opposite direction as motor vehicle traffic on one-way streets, thereby providing cyclists with a direct route and avoiding the need to traverse additional blocks to reach their destination. These lanes are clearly separated from opposing lanes with double yellow lines and, depending on conditions, sometimes have partial separation at intersections or mid-block, or complete separation. Factors to be considered during design include vehicle and bicycle turning movements, vehicle and bicycle ADT, available street width, existence of on-street parking and rate of turnover, and transit routes.

### 6.3.3 Colored Pavement

Colored pavement is used to increase the visibility of bikeways or, more commonly, zones with a high potential for motor vehicle/bicycle conflicts, by indicating cyclist right-of-way with a distinctive color. This convention is designed to remind motorists that they are crossing or adjacent to an area where they can expect to see cyclists and to take extra caution. Colored pavement can be used for very short sections of pavement (such as where a trail crosses an intersection) or for the full length of a bike lane.



Figure 6.21 – Colored Bike Lane in Sunnyvale, CA

On the down side, colored pavement can create a false sense of security for cyclists; confuse motorists since the technique is new and unfamiliar; and have high initial and maintenance costs. Options for creating colored pavement have varying degrees of permanence. Agencies interested in experimenting with colored pavement on a temporary basis can use regular paint or tennis court paint (for green lanes). These paints fade quickly and must be reapplied to

maintain an impact. A more permanent option is to embed color in the last lift of an asphalt overlay, although reapplication requires a grind-out and re-paving.

Portland, OR is the primary U.S. city using colored bike lanes; however, Sunnyvale, CA is experimenting with blue bike pavement and Petaluma, CA is trying out red bike pavement. The city of San Francisco has requested permission to experiment with colored bicycle lanes from the California Traffic Control Devices Committee, the first step toward establishing guidelines for the use of colored lanes.

### 6.3.4 Traffic Signal Detection

Bicycle detection at signalized intersections can provide a substantial safety improvement for cyclists and motorists alike. This is particularly true in rural areas where there are few signalized intersections but signals are found at crossings of state highways and other major roads. Loop detectors at signalized intersections are used to allow motorists to trigger a traffic light. The following recommendations are intended to expand typical detection loop efforts to include bicycles along designated routes and at key intersections by providing needed improvements such as calibration of existing detectors, installation of new detectors, and installation of stencils. In addition, these recommendations should be incorporated into new development requirements wherever signalized intersections are proposed.



Figure 6.22 – Pushbutton Sign for Signals

### General Recommendations

While detector loops facilitate faster and more convenient motorist trips, if they aren't calibrated properly or stop functioning, they can frustrate cyclists waiting for signals to change, unaware that the loop is not detecting their bicycle. Where appropriate, the County should ensure that all existing loops are tested annually and are calibrated and operable for bicycle users.

The County should develop a policy of installing bicycle-calibrated loop detectors at intersections along designated bike routes as they are repaved. For new installation it is recommended that the County use Type D for lead loops in all regular travel lanes shared with bicycles. Within bike lanes it is recommended that the County install Bicycle Loop Detectors (BLDs) using narrow Type C loops. Types A (6' square) and E (unmodified circle) are not bike-sensitive in their center.



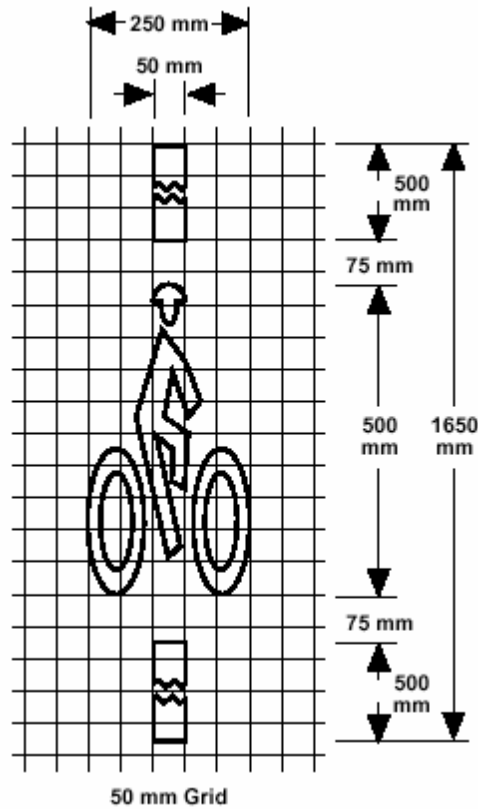

Figure 6.23 – Bicycle Detection Marking

Since most cyclists, as well as motorists, do not know how loop detectors work, all detector loops expected to be used by cyclists should be marked by a pavement stencil that shows cyclists where to stop to activate the loop. Educational materials distributed by the County should describe how to activate bicycle loop detectors. Stencils should be repainted when needed.

### Video Detection

Like in-pavement loop detectors, which have been in use throughout many jurisdictions for decades, video detection allows bicyclists to trigger traffic signals at intersections. The technology uses “detection zones” for motorists and cyclists (Figure 6.24) and is most often used at signalized intersections with dedicated bicycle lanes and that are already equipped with motor vehicle video detection.

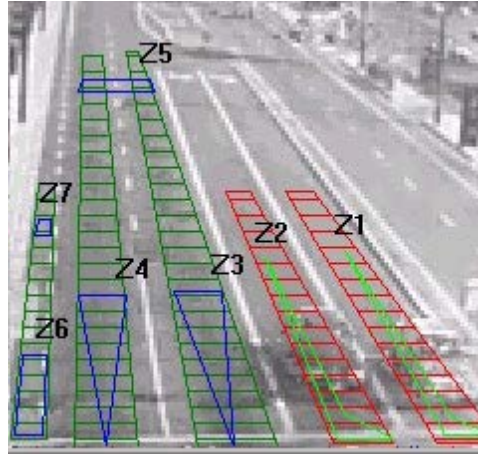

Figure 6.24 – Video Detection System

Video detection is superior to loops because it can detect any bicycle, regardless of frame material, and is not disrupted by asphalt work or other maintenance. However, if a bicyclist does not stop in the detection zone, the camera can miss him or her, thereby leaving the signal phase on red in the cyclist's direction of travel. Furthermore, this technology is compromised by weather conditions, such as heavy fog and bright sunlight. Video detection is currently in use in Santa Rosa, CA.

Assembly Bill 1581, signed into law by then Governor Schwarzenegger in January 2008, adds a section to the California Vehicle code requiring new traffic signals to detect bicycles and motorcycles. The bill applies only to new traffic actuated signals or replacement of loop detectors at a traffic actuated signal. However, Caltrans is charged with developing new signal detection method guidelines before the law takes effect on local jurisdictions.

### 6.3.5 Bicycle Signals

Bicycle signals are traffic signals equipped with signal heads that apply exclusively to cyclists. Rather than showing simple red, yellow or green lights, these specially designed signals show red, yellow or green bicycle icons, and can be used in conjunction with a pedestrian phase. Since the California Vehicle Code requires bicyclists, like autos, to obey traffic signals, local municipal codes must be changed to allow bicycles to obey bicycle signals instead.

## 6.4 Bicycle Parking and Facilities

Bicycle parking is not standardized in any state or municipal code. However, there are preferable types of secure bicycle accommodations available. Bicycle parking is a critical component of the network and facilitates bicycle travel, especially for commuting and utilitarian purposes. The provision of bicycle parking at every destination ensures that bicyclists have a place to safely secure their mode of travel. Elements of proper bicycle parking accommodation are outlined below.

### 6.4.1 Parking Classifications

Bicycle parking facilities in California are classified as follows.

- **Class I:** Class I parking is high security parking, usually with weather protection. This type of parking accommodates employees, residents, and commuters. Class I parking is considered long-term parking and is generally for those who expect to park more than two hours. Examples of Class I parking are storage lockers or restricted access covered areas that provide facilities for individually locked bicycles.

Bike lockers are covered storage units that typically accommodate one or two bicycles per locker, and provide additional security and protection from the elements. These are typically located at large employment centers, colleges, and transit stations.

Bike corrals can be found at schools, stadiums, special events, and other locations, and typically involve a movable fencing system that can safely store numerous bicycles. Either locking the enclosure or locating it near other activities so that it can be supervised provides security.

- **Class II:** Class II bicycle parking facilities are best used to accommodate visitors, customers, messengers and others expected to depart within two hours. Class II includes racks that provide two points of contact to allow both wheels and frame to be secured with a user-supplied lock. Bicycle racks provide support for the bicycle but do not have locking mechanisms. They are usually located at schools, commercial locations, and activity centers such as parks, libraries, retail locations, and civic centers.
- **Class III:** Class III bicycle parking is the least secure. It provides only for securing one wheel and frame. This parking class can include street poles or wave bicycle racks.

### 6.4.2 Effective Guidelines

Bicycle parking facilities should be designed with the following principles in mind to promote a safe, easy, and accessible experience for the commuter or recreational user.

1. Bike racks provide short-term parking. Bicycle racks should offer adequate support for the bicycles and should be easy to lock to. Figures 6.25 and 6.26 display a common inverted-U design that does this. Figure 6.27 depicts a multi-bicycle rack that works well. Figure 6.28 shows an innovative concept in which the bike rack itself looks like a bicycle.



Figures 6.25, 26 – "Inverted U" Bike Racks



Figure 6.27 – Multi-Bicycle Rack



Figure 6.28 – Bike Rack

2. Long-term parking should be provided for those needing all day storage or enhanced security. Bicycle lockers offer good long-term storage, as shown in Figure 6.29. Attendant and automated parking also serves long-term uses, which are discussed in greater detail in the next section.



Figure 6.29 – Bike Lockers

3. Bicycle parking should be clearly identified by signage, such as in the figure below. Signage should also identify the location of racks and lockers at the entrance to shopping centers, buildings, and other establishments where parking may not be provided in an obvious location, such as near a front door. Parking structures or garages for automobiles that have bicycle racks inside should have a bicycle parking sign on the exterior.



Figure 6.30 – Bicycle Parking Sign

4. Bicycle parking should be located close to the front door of buildings and retail establishments in order to provide for the convenience, visibility, and safety of those who park their bicycles.
5. Bicycle lockers should have informational signage, placards, or stickers placed on or immediately adjacent to them identifying the procedure for how to use a locker. This information at a minimum should include the following:
  - Contact information to obtain a locker at City Hall or other administrating establishment
  - Cost (if any) for locker use
  - Terms of use
  - Emergency contact information
6. Bicycle lockers should be labeled explicitly as such and shall not be used for other types of storage.



7. Bicycle racks and storage lockers should be bolted tightly to the ground in a manner that prevents their tampering.

### 6.4.3 Innovations in Bicycle Parking and Trip Facilities

According to the Association of Pedestrian and Bicycle Professionals, the lack of secure bicycle parking keeps many people from using their bikes for basic transportation. Many people are deterred from riding to work, school, shopping and other destinations, and instead drive, because of an experience with theft or the threat of theft. Providing a secure place to store bikes at cyclists' destinations is a key component of a robust regional bicycling network.

Many employers, jurisdictions and other public agencies have experimented with various bicycle parking designs for decades, including electronic lockers, bicycle stations, and various types of bicycle racks. This section provides an overview of these bicycle parking innovations and a brief discussion of the situations in which each is most appropriate.

#### Electronic Lockers

For bicyclists who need to leave their bicycles for long periods of time at transit stations or the workplace, security is a key concern. Long-term bicycle parking solutions have historically been limited to lockers, bicycle "lids," and other options that provide sheltered parking controlled with a key or padlock. The primary shortcoming of bicycle lockers is that just one user holds the key to each locker, leaving many lockers frequently empty but unavailable for rental to casual cyclists. Furthermore, while an agency may have the resources to purchase and install bicycle lockers, maintenance and administration are ongoing challenges. Lockers may be abandoned or vandalized, and frequently there are insufficient resources to maintain an accurate list of current users or respond to potential locker-renters in a timely manner.

One solution to the challenges posed by traditional bicycle lockers is the electronic locker, which is rented on an hourly basis on demand, rather than being reserved for months at a time by a single user. This allows each locker to be used by many people over a given period of time, increasing the number of bicycles stored in the lockers. Electronic lockers typically charge a small fee to discourage misuse, which is paid with a specially-designed debit card.

#### Bicycle Stations

Bicycle stations offer attended or automated long-term bicycle parking. Other services can also be available, such as bicycle repairs, sharing, rentals and retail sales. Bicycle stations can be operated by BikeStation (<http://www.bikestation.org/>), an organization that serves members and nonmembers by contracting with local partners to manage bicycle parking, service and retail facilities. Locations in Southern California include Long Beach, Covina, and Claremont. In addition, there are other, independently operated bicycle stations located at transit stations in various cities like San Francisco and Oakland, CA.

The annual operating cost of a bicycle station range from \$25,000 for a small, unstaffed facility to \$120,000-\$150,000 for a fully staffed, full-service facility. Capital costs range from \$25,000 for a secure room or cage to over \$3 million for a more extensive facility. Bicycle stations have

struggled to identify long-term revenue sources to cover their operating costs and are often subsidized by outside funding, including membership fees, grants and operating funds from transit agencies.

## 6.5 Pedestrian Design Recommendations

Walkways are the portion of the public right-of-way that provide a separated area for people traveling on foot. Walkways that are safe, accessible, and aesthetically pleasing attract pedestrians. People walk for many reasons: to go to a neighbor's house, to run errands, to school, or to get to work or a business meeting. People also walk for recreation and health benefits or for the enjoyment of being outside. Some pedestrians must walk to transit or other destinations if they wish to travel independently. Outside of private developments, it is a public responsibility to provide a safe and convenient system for those who walk.

The Federal Department of Transportation provides guidelines for the safe design of pedestrian facilities through its work in the PEDSAFE program. The PEDSAFE or Pedestrian Safety Guide and Countermeasure Selection System presents various methods of pedestrian treatments available to jurisdictions. This comprehensive report can be found online at the Pedestrian and Bicycle Information Center website at <http://www.walkinginfo.org/pedsafe/index.cfm>, and need not be repeated here. Some highlights of other facility recommendations are described below.

### 6.5.1 Multi-Modal Mindset at the Design Stage

Integration of pedestrian design philosophy requires a comprehensive commitment by numerous agencies, organizations and interests. Such a mindset once established can, over time, create communities in which pedestrian activity is encouraged rather than merely accommodated.

- Designs of new and retrofitted developments should provide accommodation not only for automobiles, but bicycles and pedestrians as well. Subdivision ordinances should specify when sidewalks are appropriate based on traffic volumes and desired character of the community (e.g. rural vs. urban design).
- Mixed-use developments with integrated land uses should be encouraged, since they can foster more pedestrian-friendly environments and generate fewer vehicle trips.
- In areas that have already been urbanized, completion of local sidewalk systems will need to be determined based on local priorities.
- A “park once” policy, in which private or public parking facilities would be built to serve downtowns or activity centers could be instituted so as to reduce trips and the number of parking spaces required.

### 6.5.2 Traffic Calming

Traffic speeds and volumes through neighborhoods are often expressed as concerns by community members. A wide range of traffic calming treatments could be introduced to address

these concerns. These can be used in combination with pedestrian treatments such as crosswalks, signing, lighting to enhance safety.

A number of calming strategies could be considered, including:

- Street trees
- Speed humps and bumps
- Corner and mid-clock curb bulbouts
- Surface treatments
- Narrower streets
- Raised intersections/crosswalks
- Enforcement of existing speed limits

See FHWA's PEDSAFE program for available traffic calming options and application criteria.

### 6.5.3 Sidewalk Plans

Roadway design criteria, sidewalk planning and prioritization can be used in each jurisdiction to address pedestrian needs on arterial roadways, bridges and school routes. Sidewalk plans should address the following issues:

- **Physical Condition:** The condition of existing sidewalks may need to be improved. Tripping obstacles range from broken and hazardous sidewalk sections to overgrown shrubs and landscaping that block passage.
- **Accessibility:** Many intersections lack curb cuts and ramps for wheelchairs. Federal ADA requirements guide the need for improvement of these facilities. Jurisdictions can focus their efforts on access to transit stations, medical facilities, employment centers, and other areas most likely to need such access improvements.
- **Connectivity:** There are numerous missing sidewalk sections along older arterial roadways, often because the site fronting the roadway has not been developed. Local jurisdictions may be able to provide sidewalks on the frontage to close gaps and recover costs in a subsequent year when the site is developed. Closing sidewalk gaps can be prioritized around transit station locations. An inventory of pedestrian treatments and deficiencies, and plans to improve them, can be conducted through a partnership with local transit agencies.
- Signage that makes existing amenities more visible and accessible to pedestrians.
- Alleviation of congestion and channelization of pedestrian/vehicular flows at school sites.
- Safe routes to school inventories and plans.
- Access to recreational facilities
- Provision of paths on rural streets in accordance with the California Vehicle Code.

### **6.5.4 Education and Awareness Building**

Awareness of the needs of pedestrians should be incorporated into school programs through the use of pedestrian safety courses. Additionally, education and pedestrian awareness issues should be incorporated into Department of Motor Vehicle driver's license tests. Across the country, schools and communities have developed "Walk Your Child to School Day" programs which incorporate local audits of the walking conditions faced not only by school children each day, but by all members of the community as well. These programs have proven effective in focusing community attention on issues ranging from local traffic enforcement, local street design and the quality of existing pedestrian facilities.

### **6.6 Bicycle Facility Maintenance**

Most of the costs for bikeway maintenance are associated with off-road bike paths, as bike lanes and routes are typically maintained as part of routine roadway maintenance. However, as bicycle lanes require occasional restriping and other maintenance, a cost of \$2,000 per mile annually is typical based on experience in other cities. This includes costs such as sweeping, replacing signs and markings, and street repair. Class I bike path maintenance costs are estimated at \$8,500 per mile, which covers labor, supplies, and amortized equipment costs for weekly trash removal, monthly sweeping, and bi-annual resurfacing and repair patrols.

Maintenance access on Class I bike paths can be achieved using standard city pick-up trucks on the pathway itself. Sections with narrow widths or other clearance restrictions should be clearly marked. Class I bike path maintenance includes cleaning, resurfacing and restriping the asphalt path, repairs to crossings, cleaning drainage systems, trash removal, and landscaping. Underbrush and weed abatement should be performed once in the late spring and again in mid-summer. In addition, these same maintenance treatments should be performed on Class II and Class III facilities. These facilities should be prioritized to include an accelerated maintenance plan that is already a part of the City's ongoing street maintenance.

It is advisable to identify a reliable source of funding to cover all new Class I, II and III bike facility maintenance. All proposed designs should be closely examined to minimize future maintenance costs. In particular, maintenance on Class II and III facilities should be accelerated.

### **6.7 Security**

Security may be an issue along portions of Class I bike paths. The following actions are recommended to address these concerns. Enforcement of applicable laws on bike paths is performed by local law enforcement agencies, using both bicycles and vehicles. Enforcement of vehicle statutes relating to bicycle operation are enforced on Class II and Class III bikeways as part of the these agencies' normal operations. No additional manpower or equipment is anticipated for Class II or III segments.

### **6.8 Liability**

Liability is a major concern for all local governments. Liability for local agencies implementing and operating new bikeways and pedestrian facilities should be no different than the liability for

new roads, parks, or schools. Local agencies should adhere to the following guidelines to minimize their liability.

### 6.8.1 Use of Design Standards

The designers, builders, and inspectors of a facility should adhere to widely accepted standards governing the design and construction of bicycle and pedestrian facilities. In addition to the Caltrans Design Manual, other applicable or useful reference standards include the Uniform Building Code; the AASHTO Guide for the Development of Bicycle Facilities, for Class I and II Bikeways; Florida Department of Transportation's Trail Intersection Design Guidelines, Island Press's "Greenways: A Guide to Planning, Design, and Development," Americans with Disabilities Act (ADA), and the Rail-to-Trails Conservancy's Trails for the 21st Century: A Planning, Design, and Management Manual for Multi-Use Trails.

Careful compliance with applicable laws, regulations, route selection criteria, and design standards should reduce the risk of injury to bicyclists using the bikeway, and also provide strong evidence that the agency used reasonable care.

### 6.8.2 Adhere to Maintenance Standards

Maintenance practice should be consistent along the entire facility, and conform to recognized maintenance practices. The responsible maintenance agency(ies) should have a written procedure to follow to maintain all portions of the facility, including the correction of pre-existing conditions such as drain grates.

### 6.8.3 Monitor Conditions

The responsible agency(ies) should have an internal mechanism to monitor and respond to actual operating conditions on the facility. This is typically done through the maintenance procedures, a record of field observations and public comments, and an annual accident analysis. Accidents should be reviewed to determine if physical conditions on the bikeway were a contributing cause. Agencies are advised against making any verbal or written comments that a facility is safe or safer than a non-designated route.

### 6.8.4 Keep Written Records and Correct Hazards

Written records of all maintenance activities and procedures, responses to reports of safety hazards, and other regular maintenance requests should be collected and regularly reviewed. While a facility may pass through numerous jurisdictions, it may make sense to have one contact person/department responsible for the entire facility, rather than risk confusion by incidents being reported to the wrong jurisdiction. Mileposts on the route may also help maintenance and enforcement personnel respond to problems. Trail managers should correct all hazards known by public officials in a timely fashion.



## 7.0 Plan Implementation

---

Chapter 1 stated that San Bernardino County can and should be one of the centers of cycling and pedestrian activity in Southern California. Subsequent chapters identified the assets and opportunities within San Bernardino County suggesting that this is possible. In addition, a robust non-motorized transportation system can be an implementation element of the overall “vision” for San Bernardino County to be a great place to live, work, and play. However, this cannot occur without a well-focused and aggressive implementation strategy.

This section identifies an implementation strategy for the NMTP and a description of funding opportunities for the proposed bicycle and pedestrian improvements. The implementation strategy consists of the following elements:

- Identification of implementation priorities (both infrastructure and institutional)
- Coordination of responsibilities for project delivery
- Identification and pursuit of funding opportunities

Each of these elements is described below.

### 7.1 Implementation Priorities

The setting of priorities for the NMTP involves more than just the identification of priority projects, although it does include that. Priorities must also consider institutional initiatives that pave the way for the delivery of priority projects. Thus, the priorities for the NMTP include the recommendations for system improvement identified in Chapter 3, plus several institutional initiatives to foster program and project delivery. The following represent NMTP priorities (not in order of importance):

8. Deliver the Class I backbone bicycle system. Although the Class I facilities can be considered a backbone bicycle system, there is much more to the network than just Class I facilities. Other types of facilities can also be delivered more quickly and less expensively, improving regional connectivity.
9. Develop better bicycle connectivity between cities and subareas of the County. This must include improved collaboration with Caltrans, given the number of State highways connecting the subareas.
10. Increase connectivity on Class II and Class III bicycle facilities by prioritizing the “low-hanging fruit” – parts of the regional system that are low-cost, close gaps in the system, and provide connections to key destinations.
11. Develop a better “sense of a system” through improved signage, markings, and way-finding for both cyclists and pedestrians.
12. Proactively coordinate integration of cycling and walking accommodations with the State’s Complete Streets requirements.

13. Proactively coordinate integration of cycling and walking access accommodations to and from transit stations.
14. Aggressively pursue grant funding and devote additional programmatic funding to non-motorized facilities.
15. Identify individuals within SANBAG, local jurisdictions, Caltrans, and transit agencies to be points of contact on non-motorized facility implementation and ensure communication on non-motorized topics among the agencies.

The full identification of Class I bicycle facilities is contained in the subarea maps in Chapter 3 and in the individual jurisdiction plans in Chapter 5. Several key Class I projects listed in the 2001 NMTP and the 2006 update that would be considered as part of the Class I backbone system include:

- Santa Ana River Trail
- Pacific Electric Trail
- Orange Blossom Trail
- San Timoteo Canyon Trail
- Riverwalk Trail
- Cajon Pass Connector – Route 66 Heritage Trail

Descriptions of the Santa Ana River Trail and Pacific Electric Trail may be found in Chapter 3. Information on the other planned facilities may be found in the individual jurisdiction sections.

## **7.2 Coordination of Responsibilities for Project Delivery**

The policies listed in Chapter 2 provide guidance as to how implementation is to occur. Local jurisdictions are responsible for the identification, prioritization, and implementation of non-motorized transportation projects within their jurisdiction, with SANBAG serving in an advisory capacity and coordinating activity where necessary. SANBAG is also to work with local jurisdictions to develop a regional way-finding system.

The policies also identify a role for SANBAG to pursue grant opportunities for State/federal bicycle and pedestrian infrastructure or planning. SANBAG will support local jurisdiction grant applications or collaborate with local jurisdictions to directly submit grant applications for projects in the Plan. The pursuit of grant application opportunities is one of the areas identified in the Plan where substantial improvement is possible, as San Bernardino County has been under-represented in the share of non-motorized grant funds that have been awarded in the past.

This Plan recognizes that regional cooperation among local agencies is critical in the selection and promotion of priority projects and the allocation of local funding to ensure an orderly implementation of an effective bicycle system.

The schedule for implementation on a year-to-year basis can be better coordinated and should be determined by:

- Relationship to the regional system;
- Readiness of each project in terms of local support;
- CEQA approvals;

- Right-of-way requirements;
- Timing with other related improvements; and/or
- Success in obtaining competitive funding.

SANBAG staff should monitor the short- and mid-term projects identified in this Plan and subsequent updates, and maintain a comprehensive list of projects and funding allocations. A rolling five-year schedule of short-term projects should be identified so that resources can be focused and coordinated to ensure attention to priority projects over time. This is not to the exclusion of other local projects, but regional connectivity to support commuting and other longer-distance trips is an emphasis of this Plan. Each year the TTAC and SANBAG staff will review the list of projects slated for priority that year, review the readiness of each project to be proposed for funding, and consider the sequencing of the projects. This process does not preclude cities and local agencies from continuing to submit other local projects for funding consideration.

### **7.3 Funding Opportunities**

There are a variety of potential funding sources - including local, state, regional, and federal programs - that can be used to construct the proposed bicycle and pedestrian improvements. Most of the federal, state, and regional programs are competitive, and involve the completion of extensive applications with clear documentation of the project need, costs, and benefits. In addition, the majority of the programs require a local match, usually 10-15% of the total project cost.

The recipients of grant funds for many of these programs are then required to monitor the projects for compliance with the program guidelines. Although the pursuit and administration of grant moneys can require a significant amount of staff time, grant funding allows for the construction of more miles of facilities.

The key to receiving funds will be to tailor grant requests to meet specific requirements and criteria, leverage grants with matching funds, and demonstrate a commitment by the jurisdiction to implement and maintain the system. Serious intent would include adoption of the NMTP, development of an additional local plan, inclusion of bikeway improvements into the Capital Improvements Plan, adoption of recognized design and operating standards, and public/political support.

A detailed breakdown of available funding programs is provided on the following pages. Tracking program specifics can be difficult as program guidelines are modified regularly. Thus it is important to verify program dates and deadlines with the program administrator since specific amounts and deadlines can change from year to year.

#### **7.3.1 Federal Funding**

**Safe Accountable Flexible Efficient Transportation Equity Act: A Legacy for Users (SAFETEA-LU) and Subsequent Federal Authorizations**

SAFETEA-LU sets the framework for spending federal transportation revenue. SAFETEA-LU expires with the federal fiscal year in 2009, and Congress will adopt successor legislation with new funding programs and guidelines. Many of the programs described in this section may remain.

Federal funding through SAFETEA-LU will likely provide some of outside funding for the NMTP projects. SAFETEA-LU currently contains three major programs that fund bikeway and/or trail projects; Surface Transportation Program (STP), Transportation Enhancement Activities (TEA), and Congestion Mitigation and Air Quality Improvement (CMAQ) along with other programs such as the National Recreational Trails Fund, Section 402 (Safety) funds, Scenic Byways funds, and Federal Lands Highway funds.

SAFETEA-LU funding is administered through the California Department of Transportation (Caltrans) and SANBAG. An annual Call-for-Projects competitive allocation process can be used to determine project funding. A local match is often required for receipt of funds.

### **Safe Routes to School (SRTS)**

As of 2006, a new federal Safe Routes to School program offers grants to local agencies and others for facilities and programs. Bikeways, sidewalks, intersection improvements, traffic calming and other projects that enhance bicycle and pedestrian safety to elementary and middle schools are eligible. Safety education, enforcement and promotional programs are also eligible.

Caltrans administers this grant funding and releases the funds in multi-year cycles. Approximately \$46 million was spent statewide in 2008 SRTS-funded projects. The funds are distributed to each Caltrans district according to school enrollment. District 8 (Riverside and San Bernardino Counties) received approximately \$6.5 million. Local jurisdictions, school districts and other agencies compete for these funds. This program will have to be reauthorized with the federal transportation bill.

## **7.3.2 State Funding**

### **Local Transportation Fund TDA Article III (SB 821)**

Transportation Development Act (TDA) Article III funds are state block grants awarded annually to local jurisdictions for bicycle and pedestrian projects in California with about \$700,000 awarded for San Bernardino County. These funds originate from the state gasoline tax and are distributed to counties based on population, with a competitive process administered by SANBAG for local jurisdictions.

### **Clean Air Funds**

AB 434 funds are available for clean air transportation projects, including bicycle and pedestrian projects, in California. Please check your local Air Pollution Control District (Southern California Air Quality Management District or the Mojave Desert Air Quality Management District) for attainment and funding status.

### **State Bicycle Transportation Account**

The State Bicycle Transportation Account (BTA) is an annual statewide discretionary program that is available through the Caltrans Bicycle Facilities Unit for funding bicycle projects. Available as grants to local jurisdictions, the emphasis is on projects that benefit bicycling for commuting purposes. The state legislature has historically authorized about \$7.2 million per year.

<http://www.dot.ca.gov/hq/LocalPrograms/>

### **Safe Routes to School (AB 1475)**

The Safe Routes to School (SR2S) program uses allocated funds from the Hazard Elimination Safety (HES) program of SAFETEA-LU. This program, initiated in 2000, is meant to improve school commute routes by improving safety to bicycle and pedestrian travel through bikeways, sidewalks, intersection improvements, traffic calming and ongoing programs. This program funds improvements for elementary, middle and high schools. A local match of 10 percent is required for this competitive program, which allocates over \$20-million annually or \$40 million to \$45 million in two-year cycles. Each year the state legislature decides whether to allocate funds to the program or not.

<http://www.dot.ca.gov/hq/LocalPrograms/saferoute.htm>

### **Office of Traffic Safety (OTS)**

The Office of Traffic Safety (OTS) seeks to reduce motor vehicle fatalities and injuries through a national highway safety program. Priority areas include police traffic services, alcohol and other drugs, occupant protection, pedestrian and bicycle safety, emergency medical services, traffic records, roadway safety and community-based organizations. The OTS provides grants for one to two years. The California Vehicle Code (Sections 2908 and 2909) authorizes the apportionment of federal highway safety funds to the OTS program. Bicycle safety programs are eligible programs for OTS start-up funds. City agencies are eligible to apply.

### **Environmental Enhancement and Mitigation Program (EEMP)**

EEM Program funds are allocated to projects that offset environmental impacts of modified or new public transportation facilities including streets, mass transit guideways, park-n-ride facilities, transit stations, tree planting to mitigate the effects of vehicular emissions, off-road trails, and the acquisition or development of roadside recreational facilities. The State Resources Agency administers the funds.

### **AB 2766**

AB 2766 Clean Air Funds are generated by a surcharge on automobile registration. The South Coast Air Quality Management District (AQMD) allocates 40 percent of these funds to cities according to their proportion of the South Coast's population for projects that improve air quality. The projects are up to the discretion of the city and may be used for bicycle projects that could

encourage people to bicycle in lieu of driving. The other 60 percent is allocated through a competitive grant program that has specific guidelines for projects that improve air quality. The guidelines vary and funds are often eligible for a variety of bicycle projects.

### **7.3.3 Local Funding**

#### **New Construction**

Future road widening and construction projects are one means of providing bike lanes and pedestrian infrastructure. To ensure that roadway construction projects provide bike lanes where needed, appropriate and feasible, it is important that an effective review process is in place so that new roads meet the standards and guidelines presented in this master plan. In San Bernardino County, new or widened arterials, and the bicycle facilities that accompany them, may be funded through a combination of Measure I half-cent sales tax funds, development fees, and other local funds.

#### **Environmental Review**

Impacts to bicycle and pedestrian circulation and safety should be analyzed in all CEQA documents in the County with appropriate mitigations identified as needed. This mechanism represents a significant opportunity to ensure that non-motorized improvements are included as a component of new transportation projects.

#### **Mello-Roos Community Facilities Act**

Bike paths, lanes, and pedestrian facilities can be funded as part of a local assessment or benefit district. Defining the boundaries of the benefit district may be difficult unless the facility is part of a larger parks and recreation or public infrastructure program with broad community benefits and support.

#### **Other Local Revenue Sources**

Local sales taxes, fees, and permits may be implemented, subject to local approval. Volunteer programs may substantially reduce the cost of implementing some of the proposed pathways. Use of groups such as the California Conservation Corp (who offers low cost assistance) will be effective at reducing project costs. Local schools or community groups may use the bikeway or pedestrian project as a project for the year, possibly working with a local designer or engineer. Work parties may be formed to help clear the right of way where needed. A local construction company may donate or discount services. A challenge grant program with local businesses may be a good source of local funding, where corporations ‘adopt’ a bikeway and help construct and maintain the facility.

Other opportunities for implementation will appear over time that may be used to implement the system.